



Thanks to the accurate rounded design and the overall linearity, these cylinders are used in those industrial sectors (food & beverages, pharmaceuticals) where technological reliability and easy cleaning are required.

TECHNICAL CHARACTERISTICS

Working pressure: 1,5 ÷ 10 bar
 Ambient temperature: -20 ÷ 80°C
 Fluid: filtered air, lube or non lube
 Barrel: stainless steel with crimped heads, and piston rod in stainless steel.
 Standard strokes (see table page 4)
 Type M160 ... up to 50 mm stroke max
 Type M170 ... up to 25 mm stroke max
 Max speed: up to 2 m/sec. without adjustable cushion
 up to 5 m/sec. with adjustable pneumatic cushion



6432

Upon request

- Magnetic version Ø 10 ÷ 25 mm. Magnetic sensor series DH-... (section accessories page 2) (for Ø 16 mm only with chromium-plated rod magnetic switch DH-500).
- Locking device Ø 16 ÷ 25 mm (section High-Tech page 3) to be coupled **only** with chromium-plated rod M2...series
- Slide unit from Ø 16 (section High-Tech page 31).



Codification key

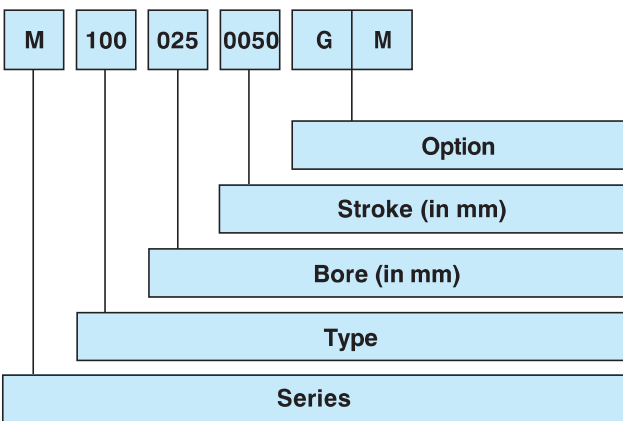

- [- . 0 . 0] **D.A.** Standard version.
- [- . 0 . 1] **D.A.** Through piston rod
- [- . 5 . 0] **D.A.** With adjustable limit switch cushioning from Ø 16 ÷ 25 mm
- [- . 5 . 1] **D.A.** Through rod with adjustable limit switch cushioning from Ø 16 ÷ 25 mm
- [- . 6 . 0] **S.A.** Retracted piston rod Ø 10 ÷ 25 mm, max. stroke 50 mm.
- [- . 7 . 0] **S.A.** Extended piston rod Ø 16 ÷ 25 mm, max. stroke 50 mm.

SERIES

M = microcylinders Ø 8 ÷ 25 mm

TYPE

- [1 . . . -] Stainless steel rod standard version.
- [2 . . . -] Chromium-plated steel rod to be used only with locking unit.
- [3 . . . -] Stainless steel rod reduced version.
- [5 . . . -] Stainless steel rod reduced version with rear supply.

BORE

Ø 008 - 010 - 012 - 016 - 020 - 025

STROKE

0010-0020-0025-0030-0040-0050-0075-0080-0100-0125-0150-0160-0175-0200-0250-0300-0320-0400-0500

OPTION

F = For use with locking unit with "reduced dimensions"
 M = Magnetic version from Ø 10 ÷ 25

Main construction features

- Stainless steel barrel AISI 304.
- Anodized aluminium extrusion heads, crimped on the barrel
- Mechanical rubber shock absorbers standard mounted on heads (M100... series) Ø 12 ÷ 25 mm
- Adjustable pneumatic cushioning with adjustment screw (M150...series) Ø 16-20-25 mm
- Seals in self-lubricating nitrile
- Piston bearing in acetalic resin: Ø 16 - 20 - 25 mm
- Rolled rod in stainless steel X10CrNi S 18.09 (AISI 303)
- Ø 20 ÷ 25 mm aluminium piston
Ø 8 ÷ 16 mm brass piston
- Microcylinders are supplied with nut on the rod (MF - 16 + Ø) and nut on the front head (MF - 20 + Ø)

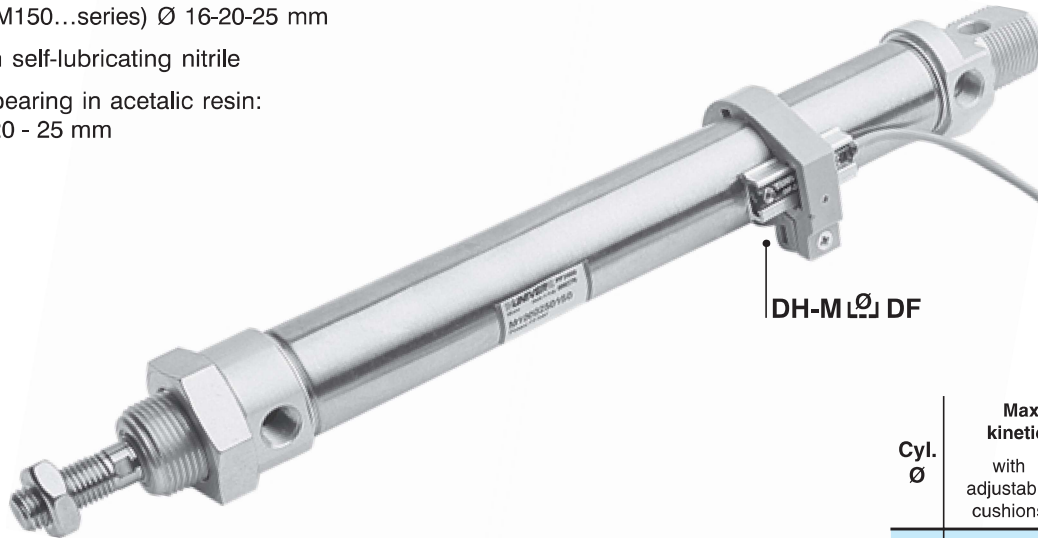

Cyl. Ø	Max absorbable kinetic energy (Nm)	
	with adjustable cushions	without adjustable cushions
16	0,9	0,12
20	1,3	0,16
25	1,8	0,22

Single-acting microcylinder

Cyl. Ø	Standard strokes (preferable values according to UNI 4393 in black)		Thrust force (min-max) of the spring (N)								Mass of moving parts		Cylinder mass	
	160	170	Stroke 10	Stroke 25	Stroke 40	Stroke 50	Stroke 0 kg	Increase by mm (g)	Stroke 0 kg	Increase by mm (g)				
10	10 - 25 40 - 50		6,9	7,6	5,8	7,6	4,7	7,6	4	7,6	0,009	0,1	0,038	0,23
12	10 - 25 40 - 50		8,1	8,7	7,3	8,7	6,5	8,7	5,9	8,7	0,023	0,22	0,079	0,38
16	10 - 25 40 - 50	10 - 25	14,4	16	11,9	16	9,4	16	7,8	16	0,026	0,22	0,085	0,43
20	10 - 25 40 - 50	10 - 25	18,6	20	16,5	20	14,4	20	13	20	0,045	0,4	0,167	0,66
25	10 - 25 40 - 50	10 - 25	21,8	23,5	19,3	23,5	16,7	23,5	15	23,5	0,08	0,62	0,238	0,95

Double-acting microcylinder



Cyl. Ø	Standard strokes (preferable values according to UNI 4393 in black)													Thrust force (min) at 6 bar (N)	Traction force at 6 bar (N)	Mass of moving parts		Cylinder mass		Length of decel. mm (g)				
	Stroke 0 (kg)	Increase by mm (g)	Stroke 0 (kg)	Increase by mm (g)																				
8	10	20	25	30	40	50	75	80	100	125	150	160		20	16	0,007	0,1	0,037	0,21	-				
10	10	20	25	30	40	50	75	80	100	125	150	160		35	32	0,009	0,1	0,038	0,23	-				
12	10	20	25	30	40	50	75	80	100	125	150	160	175	200	250	50	38	0,023	0,22	0,078	0,38	-		
16	10	20	25	30	40	50	75	80	100	125	150	160	175	200	250	90	87	0,023	0,22	0,085	0,43	16		
•16		25	30	40	50	75	80	100	125	150	160	175	200	250	300	320	400	500	0,025		0,087			
20	10	20	25	30	40	50	75	80	100	125	150	160	175	200	250	300		148	140	0,045	0,4	0,167	0,66	18
•20		25	30	40	50	75	80	100	125	150	160	175	200	250	300	320	400	500	0,048		0,17			
25	10	20	25	30	40	50	75	80	100	125	150	160	175	200	250	300	320	400	500	0,080	0,62	0,237	0,95	22
•25		25	30	40	50	75	80	100	125	150	160	175	200	250	300	320	400	500	0,088		0,245			

- Version with pneumatic cushioning

UNIVER is able to supply the cylinders with stroke variations of one millimeter (intermediate strokes) or strokes exceeding the standard stroke.

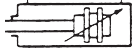
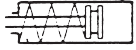

Double/single-acting cylinder

-  **Series M 100**
-  **Series M 150**
-  **Series M 160**
-  **Series M 170**

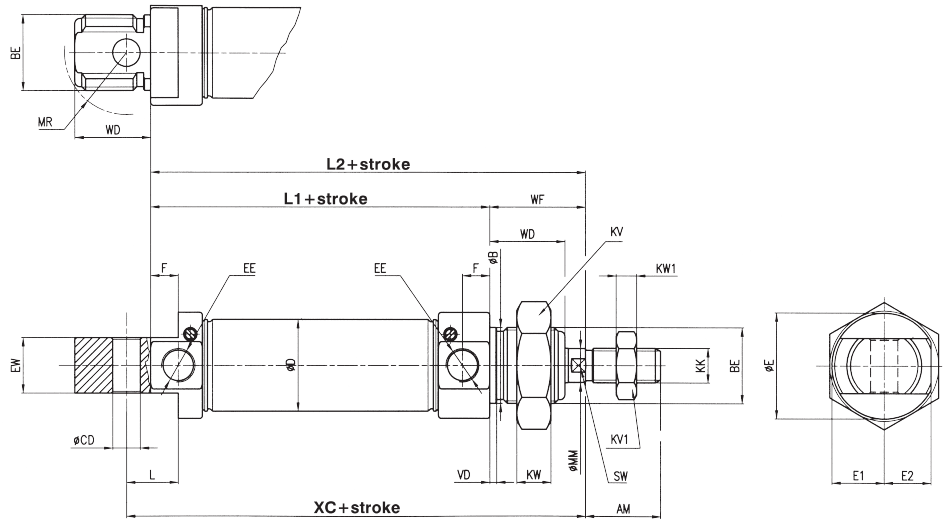

Double-acting through rod cylinder

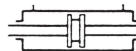
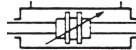
-  **Series M 101**
-  **Series M 151**

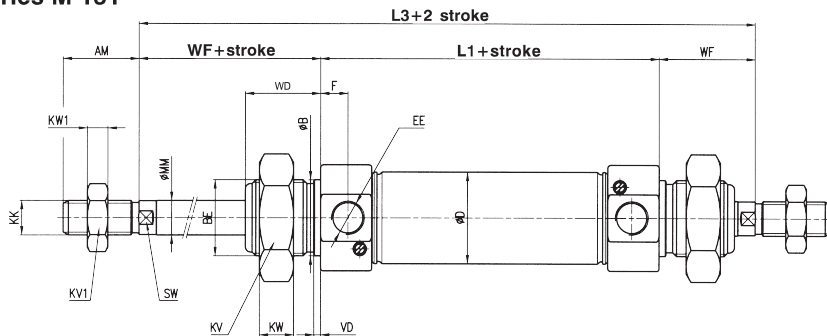

Cyl. Ø	AM	B	Ø BA	BE	CD	D	Ø E	E1	E2	* EE	EW	KV	KV1
		h 10			H9						d 13		
8	12	12		M12 x 1,25	4	9,3	14	8	8,5	M5 x 0,8	8	19	7
10	12	12		M12 x 1,25	4	11,3	14	8	8,5	M5 x 0,8	8	19	7
12	16	16		M16 x 1,5	6	13,3	17	9,5	10	M5 x 0,8	12	24	10
16	16	16	16	M16 x 1,5	6	17,3	20,8	10,4	9,6	M5 x 0,8	12	24	10
20	20	22	22	M22 x 1,5	8	21,6	27,7	13,85	12	G 1/8	16	32	13
25	22	22	22	M22 x 1,5	8	26,6	30,7	15,35	13,75	G 1/8	16	32	17

Cyl. Ø	F	KK	KW	KW1	L	L1	L2	L3	MM	MR	SW	VD	WA	WD	WF	XC
															± 1,2	± 1
8	5	M4 x 0,7	7	2,8	7	46	62	78	4	12	3	1,5		12	16	64
10	5	M4 x 0,7	7	2,8	7	46	62	78	4	12	3	1,5		12	16	64
12	5	M6 x 1	8	4	9	50	72	94	6	16	5	1,5		17	22	75
16	5,5	M6 x 1	8	4	8	56	78	100	6	16	5	1,5	5,5	17	22	82
20	8	M8 x 1,25	10	5	11	68	92	116	8	18	7	2	5,5	19	24	95
25	8	M10 x 1,25	10	6	15	69	97	125	10	18	9	2	7,5	22	28	104

* The series with dimensions in inches is chosen in compliance with UNI-ISO 228/1 standard



Double-acting cylinder Series 350 with cushioning Ø 16-20-25 mm

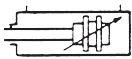

Series M 350

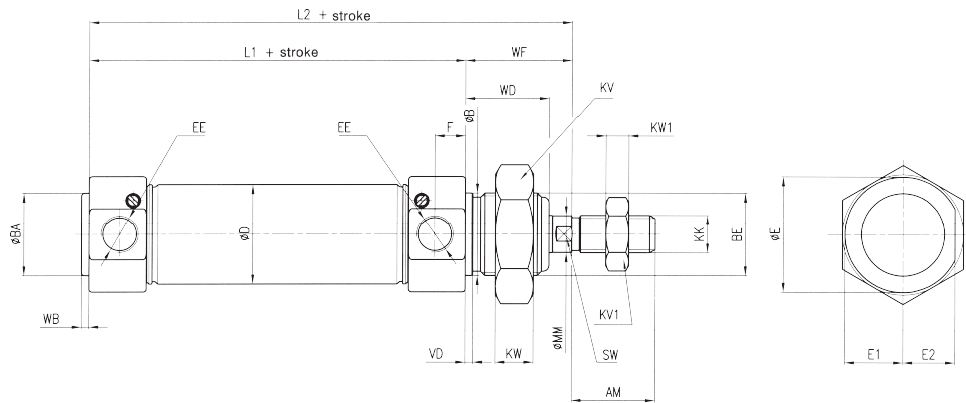

Double acting cylinder with standard air supply Ø 10 ÷ 25 mm

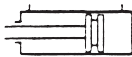

Series M 300

Double-acting cylinder with rear supply Ø 10 ÷ 25 mm

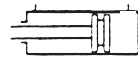

Series M 500

Single-acting cylinders retracted piston rod Ø 10 ÷ 25 mm; single-acting extended piston rod Ø 16-25 mm, both with standard supply.

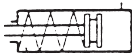

Series M 360

Single-acting cylinder retracted piston-rod with rear supply Ø 10 ÷ 25 mm



Series M 560



Series M 370

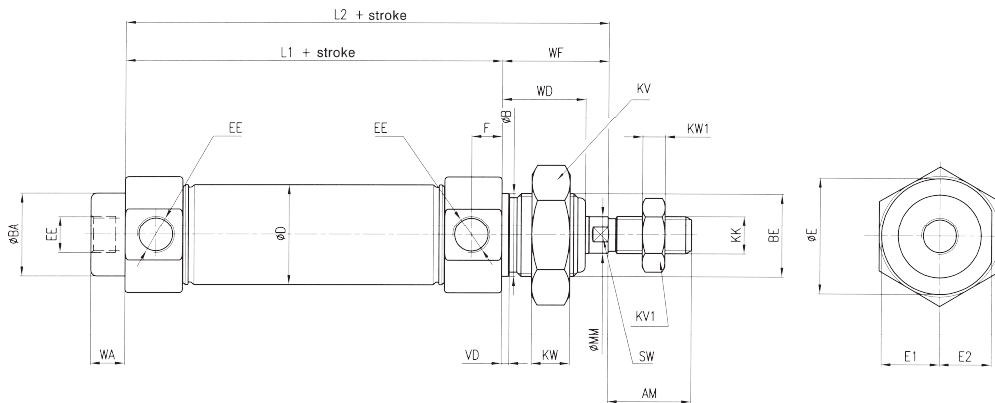

Cyl. Ø	AM	B h10	BA Ø	BE	D	E Ø	E1	E2	*EE	KV	KV1
10	12	12	12	M12 x 1,25	11,3	15,8	7,9	7,2	M5 x 0,8	19	7
12	16	16	16	M16 x 1,5	13,3	18,8	9,4	8,7	M5 x 0,8	24	10
16	16	16	16	M16 x 1,5	17,3	20,8	10,4	9,6	M5 x 0,8	24	10
20	20	22	22	M22 x 1,5	21,6	27,7	13,85	12	G 1/8	32	13
25	22	22	22	M22 x 1,5	26,6	30,7	15,35	13,75	G 1/8	32	17

Cyl Ø	F	KK Z	KW	KW1	L1	L2	MM	SW	VD	WA	WB	WD	WF ± 1,2
10	5	M4 x 0,7	7	2,8	46	62	4	3	1,5	4		12	16
12	5	M6 x 1	8	4	50	72	6	5	1,5	4,5		17	22
16	5,5	M6 x 1	8	4	56	78	6	5	1,5	5,5	1,5	17	22
20	8	M8 x 1,25	10	5	68	92	8	7	2	5,5	2	19	24
25	8	M10 x 1,25	10	6	69	97	10	9	2	9	2	22	28

* The series in inches is according to UNI-ISO 228/1

Foot bracket in zinc-plated steel for $\varnothing 8 \div 25$ mm (MS 3)

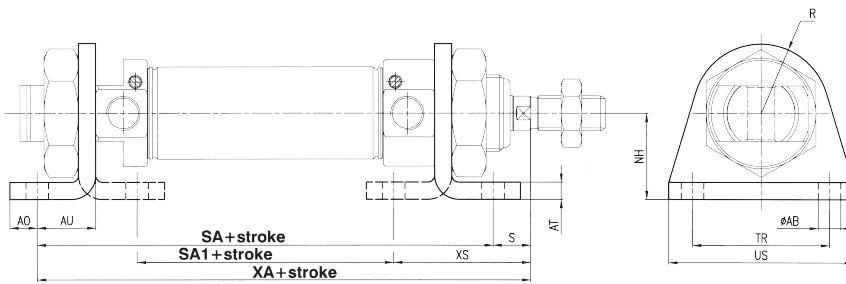

Cyl. \varnothing	AB	AO	AT	AU	NH	R	S	SA	SA1	TR	US	XA	XS	Mass kg	Part number
	H13			+0,3 0	$\pm 0,3$					Js14			$\pm 1,4$		
8-10	4,5	5	3	11	16	10	5	68	30	25	35	73	24	0,02	MF-13008
12	5,5	6	4	14	20	13	8	78	30	32	42	86	32	0,04	MF-13012
16	5,5	6	4	14	20	13	8	84	36	32	42	92	32	0,04	MF-13012
20	6,6	8	5	17	25	20	7	102	44	40	54	109	36	0,09	MF-13020
25	6,6	8	5	17	25	20	11	103	45	40	54	114	40	0,09	MF-13020

Flange in zinc-plated steel for $\varnothing 8 \div 25$ mm (MF8)

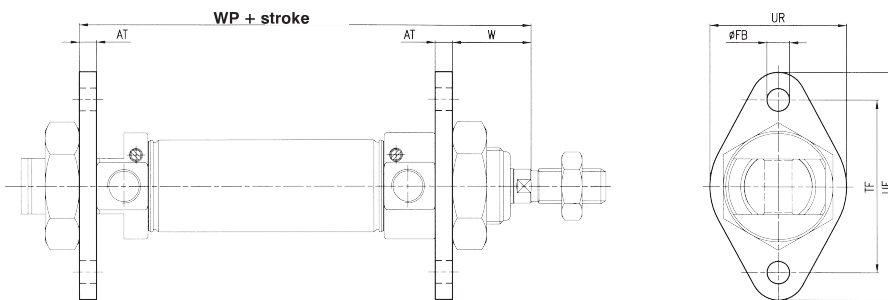

Cyl. \varnothing	AT	FB	TF	UF	UR	W	WP	Mass kg	Part number
		H13	Js14			$\pm 1,4$			
8-10	3	4,5	30	40	25	13	65	0,012	MF-12008
12	4	5,5	40	53	30	18	76	0,025	MF-12012
16	4	5,5	40	53	30	18	82	0,025	MF-12012
20	5	6,6	50	66	40	19	97	0,049	MF-12020
25	5	6,6	50	66	40	23	102	0,049	MF-12020

Rear female hinge in zinc-plated steel $\varnothing 8 \div 25$ mm with pin and 2 circlips

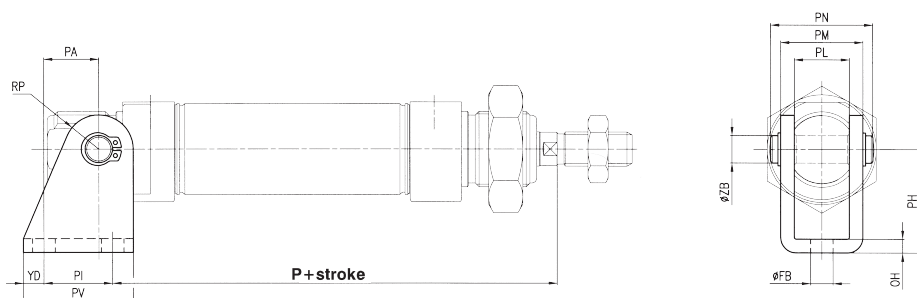

Cyl. Ø	Ø FB	OH	P	PA	PH	PI	PL	PM	PN	PV	RP	YD	ZB	Mass kg	Part number
	H13					E9						f8			
8-10	4,5	2,5	62,5	11	24	12,5	8,1	13,1	17	20	5,3	3,8	4	0,019	MF - 21008
12	5,5	3	73	13	27	15	12,1	18,1	23	25	7	5	6	0,037	MF - 21012
16	5,5	3	80	13	27	15	12,1	18,1	23	25	7	5	6	0,037	MF - 21012
20	6,6	4	91	16	30	20	16,1	24,1	30	32	10	6	8	0,08	MF - 21020
25	6,6	4	100	16	30	20	16,1	24,1	30	32	10	6	8	0,08	MF - 21020

Nut for zinc-plated steel rod

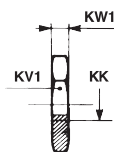
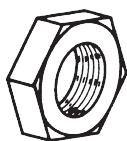

Cyl. Ø	KK	KW1	KW1	Part number
8-10	M4 x 0,7	7	2,8	MF - 16008
12-16	M6 x 1	10	4	MF - 16012
20	M8 x 1,25	13	5	MF - 16020
25	M10 x 1,25	17	6	KF - 16032

Nut for zinc-plated steel head

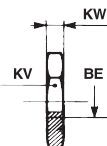
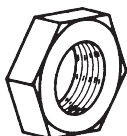

Cyl. Ø	BE	KV	KW	Part number
8-10	M12 x 1,25	19	7	MF - 20008
12-16	M16 x 1,5	24	8	MF - 20012
20-25	M22 x 1,5	32	10	MF - 20020



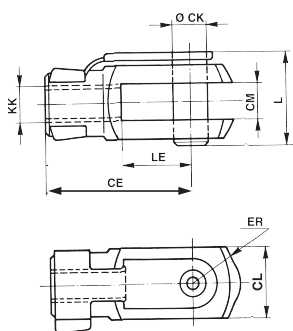

Double hinge in zinc-plated steel with pin for ISO 8140 rod



Cyl. Ø	CE	CK	CL	CM B12 B12	ER	KK	L	LE	Mass kg	Part number
8-10	16	4	8	4	5	M4 x 0,7	11	8	0,007	MF - 15008
12-16	24	6	12	6	7	M6 x 1	16	12	0,019	MF - 15012
20	32	8	16	8	10	M8 x 1,25	22	16	0,046	MF - 15020
25	40	10	20	10	16	M10 x 1,25	26	20	0,09	KF - 15032

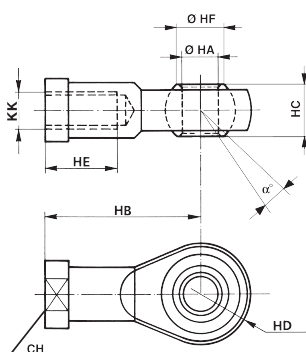

Articulated self-lubricating fork in zinc-plated steel



Cyl. Ø	a	CH	KK	HA	HB	HC	HD	HE	HF	Mass kg	Part number
				H7			0 -0,12				
8-10	13°	9	M4 x 0,7	5	27	8	9	10	7,7	0,018	MF - 17008
12-16	13°	11	M6 x 1	6	30	9	10	12	9	0,026	MF - 17012
20	14°	14	M8 x 1,25	8	36	12	12	16	10,4	0,046	MF - 17020
25	13°	17	M10 x 1,25	10	43	14	14	20	12,9	0,076	KF - 17032

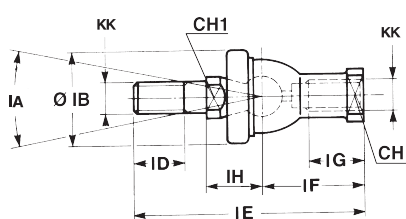

Fork with axially mounted articulated pin

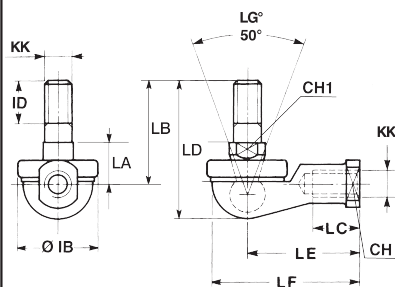

Cyl. Ø	CH	CH1	IA	KK	IH	IB	ID	IE	IF	IG	Mass kg	Part number
					±0,3							
12-16	11	8	30°	M6 x 1	12,2	22	11	55,2	28	15	0,04	MF - 22016
20	14	10	30°	M8 x 1,25	16	28	12	65	32	16	0,075	MF - 22020
25	17	11	30°	M10 x 1,25	19,5	32	15	74,5	35	18	0,12	KF - 22025

Fork with angle-mounted articulated pin



Cyl. Ø	CH	CH1	LG	KK	IB	ID	LA	LB	LC	LD	LE	LF	Mass kg	Part number
							±0,3							
12-16	11	8	50°	M6 x 1	22	11	11	26	14	35,5	30	40	0,037	MF - 23012
20	14	10	50°	M8 x 1,25	28	12	14	31	17	42,5	36	48	0,067	MF - 23020
25	17	11	50°	M10 x 1,25	32	15	17	37	21	50,5	43	57	0,11	KF - 23025