

K Ø160 - 200

Pneumatic cylinders Ø 160-200 mm according to ISO 15552

NEW DESIGN of end caps in die-cast aluminium alloy.

UNIVER pneumatic cylinders which comply with ISO 6431 and VDMA 24562 standards, take advantage of the improvements arising from the research of the last years; infact, they can fully satisfy the most demanding users.

The operation with non-lubricated air is worth mentioning, since it allows their use in many industrial sectors while protecting the environment. The strong construction and the selected components contribute to giving them excellent operating features and a very long life.

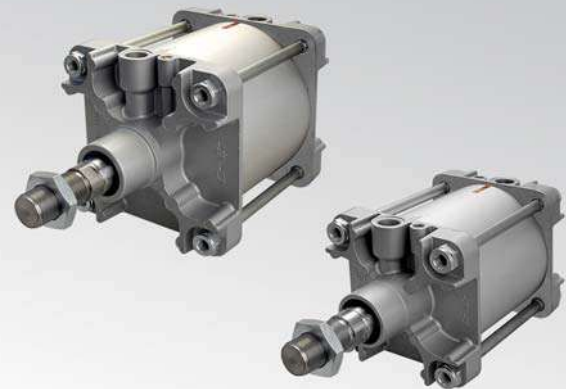

TECHNICAL CHARACTERISTICS

Ambient temperature	-20 ÷ 80 °C
Fluid	filtered air with or not lubrication
Working pressure	1,5 ÷ 10 bar
Bore size	Ø160 - 200 mm
Cushion	adjustable pneumatic cushion in both sides

CONSTRUCTIVE CHARACTERISTICS

End caps	die-cast aluminium alloy
Barrel	aluminium anodized
Tie rod	zinc-plated steel
Piston	die-cast aluminium alloy
Piston rod guide	acetal resin
Piston rod	C43 chromium-plated steel upon request stainless steel (AISI 303)
Piston rod seal	NBR
Piston seal	nitrile rubber self lubricating
Magnet ring	plastroferrite

> Upon request non magnetic version with VITON® seal
(Max Temperature 110 °C)

CODIFICATION KEY

K	2	0	0	1	6	0	0	1	0	0	M
1	2	3	4		5			6			

1 Series	2 Type	3 Version	4 Bore size (mm)
K = Ø 160 - 200 mm Magnetic upon request	1 = Stainless steel piston rod 2 = Chromium-plated piston rod	00 = D.E. Standard piston rod 01 = D.E. Through piston rod	160 = Ø160 200 = Ø200

5 Stroke	6 Variant
0025 = 25 mm 0125 = 125 mm 0250 = 250 mm 0450 = 450 mm 0900 = 900 mm 0050 = 50 mm 0150 = 150 mm 0300 = 300 mm 0500 = 500 mm 1000 = 1000 mm 0075 = 75 mm 0160 = 160 mm 0320 = 320 mm 0600 = 600 mm 0080 = 80 mm 0175 = 175 mm 0350 = 350 mm 0700 = 700 mm 0100 = 100 mm 0200 = 200 mm 0400 = 400 mm 0800 = 800 mm	M = Upon request magnetic version

D.E. = double acting



Stroke tolerances

Ø	Z ≤ 500	501 ≤ Z ≤ 1.250
	mm	mm
160	+4 - 0	+5 - 0
200	+4 - 0	+5 - 0

Theoretical forces (N)
at different working pressure (bar)

Cushion

Ø	Surface area		Working pressure					Working pressure					Lenght	Max kinetic energy
	mm ²		bar					bar						
	Thrust	Traction	Thrust					Traction						
			2	4	6	8	10	2	4	6	8	10	mm	Nm
160	20096	18840	4019	8038	12058	16077	20096	3770	7540	11310	15080	18850	45	52
200	31400	30144	6280	12560	18840	25120	31400	6029	12058	18066	24115	30144	45	95

Standard cylinder mass

Ø	Stroke 0	Increase for mm stroke	Moving part-stroke 0	Increase for mm stroke
	g	g	g	g
160	14600	16,9	4020	9,9
200	16500	18,5	4780	9,9

Through piston rod cylinder mass

Ø	Stroke 0	Increase for mm stroke	Moving part-stroke 0	Increase for mm stroke
	g	g	g	g
160	16850	26,80	5940	19,8
200	19900	28,40	6800	19,8

Graph of theoretical forces/pressure
Graph of acceptable strokes depending on maximum peak load

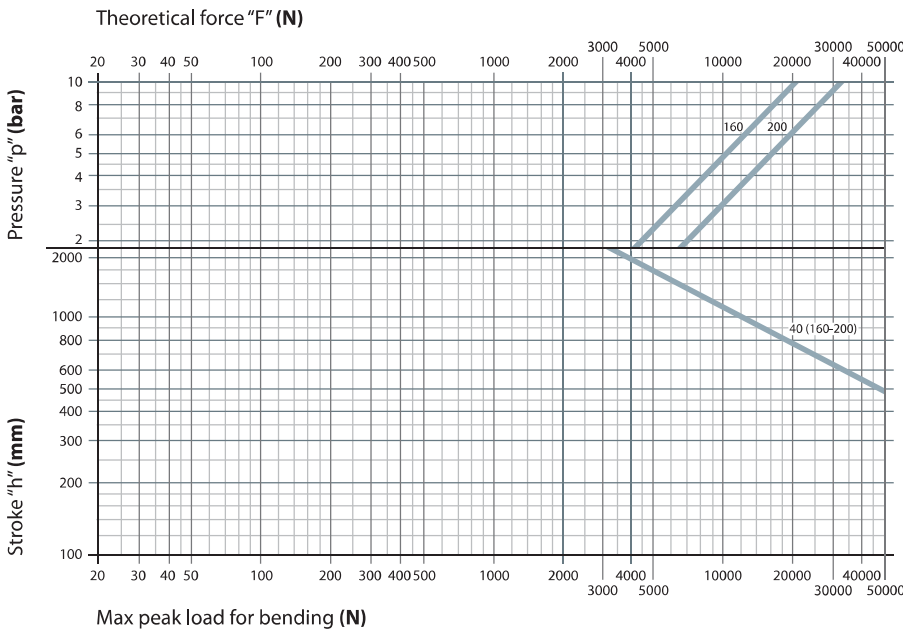

> Fixing

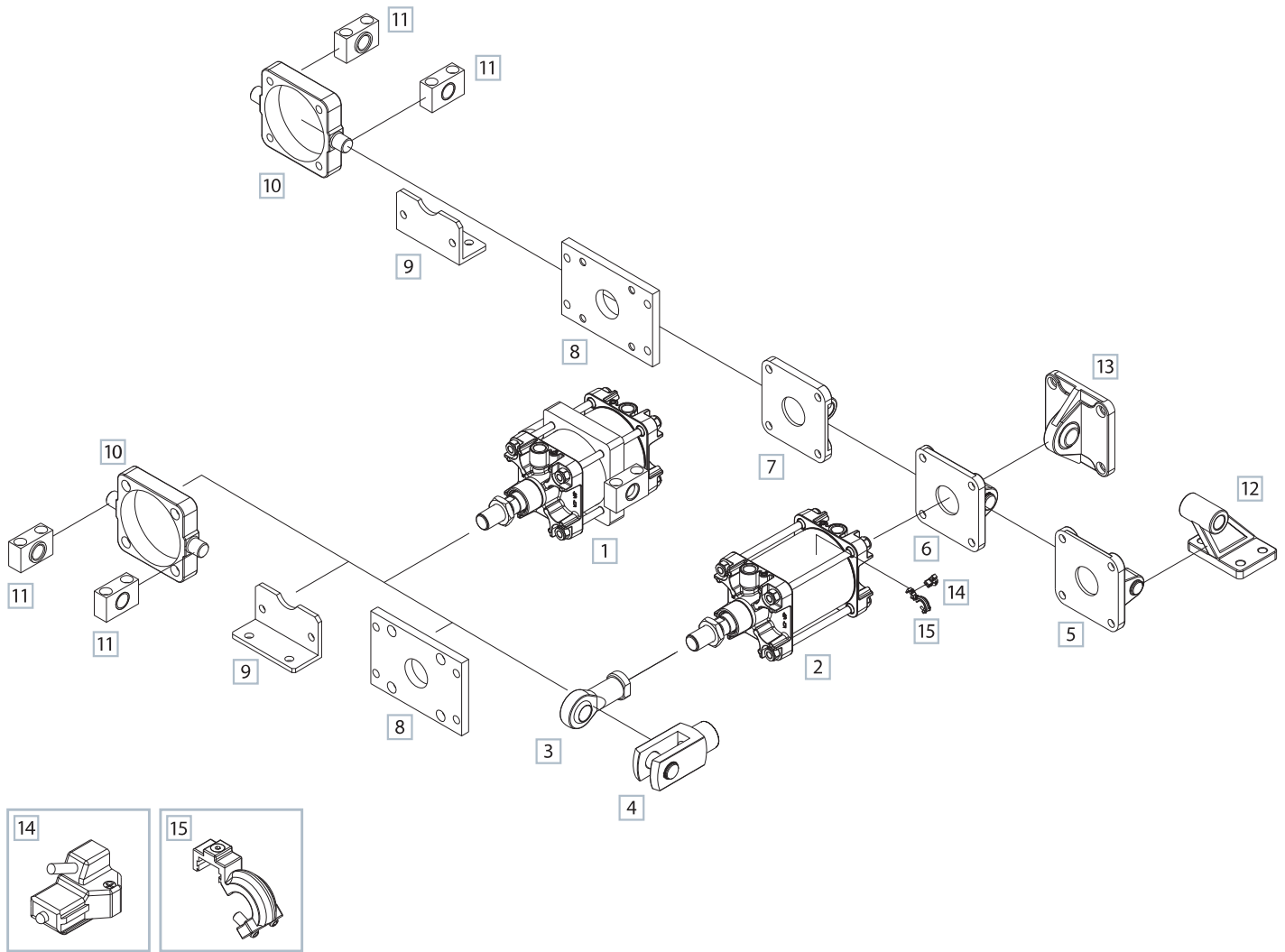

DESCRIPTION	PART NO.
1 ISO cylinder with intermediate hinge	-
2 ISO cylinder	-
3 Articulated self-lubricating fork	KF-17_ _ _
4 Fork with clips DIN 71752	KF-15_ _ _
5 Female rear hinge with pin	KF-10_ _ _ A
6 Narrow female rear hinge with pin	KF-10_ _ _ AS
7 Male rear hinge	KF-11_ _ _
8 Front- rear flange	KF-12_ _ _
9 Foot bracket	KF-13_ _ _
10 Front-rear hinge	KF-14_ _ _ AP
11 Support for front-rear-intermediate hinge	KF-41_ _ _
12 Counter hinge 90° ISO	KF-19_ _ _ CTA
13 Articuled narrow counter-hinge	KF-11_ _ _ S
14 Magnetic sensor	DH-200
15 Bracket for magnetic sensor	DH-K160200

Standard version

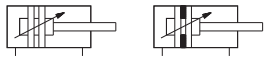
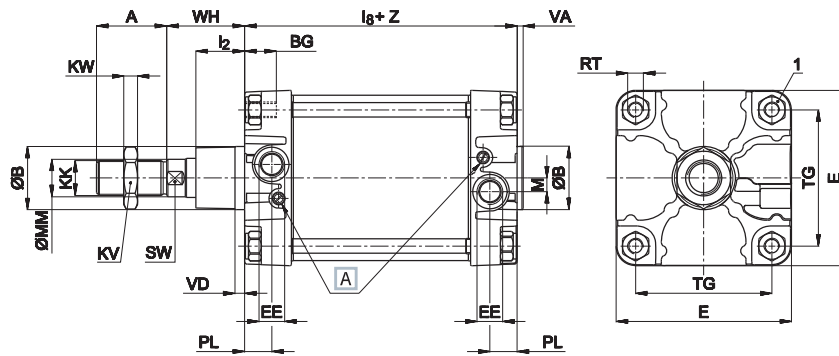

Through piston rod version

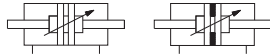
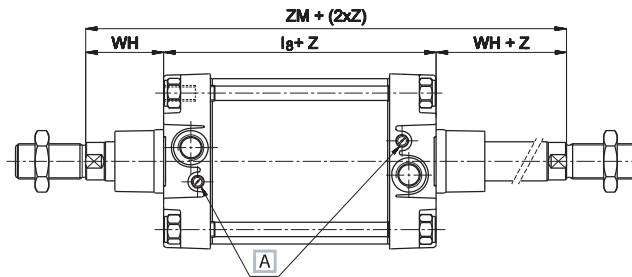

A Adjusting cushion screws

Z = stroke

Ø	A ^(a)	B	BG	E	EE ^(b)	KK ^(a)	KV	KW	l ₂	l _s		M
		e11								nom.	toll.	
160	72	65	25	180	G3/4	M36x2	55	14	50	180	±1,1	14
200	72	75	25	220	G3/4	M36x2	55	14	60	180	±1,1	14

Ø	MM	PL	RT	SW	TG		VA	VD	WH		ZM	1 (chiave)
					nom.	toll.			nom.	toll.		
160	40	28	M16	36	140	±1,1	6	9	80	±2,2	340	27
200	40	27	M16	36	175	±1,1	6	9	95	±2,2	370	27

(a) = A e KK dimension in according to ISO 4395

(b) = EE in according to ISO 228/1