



The wide product range and unique design make Univer "Short stroke cylinders W series" essential for all applications where compact overall dimensions and short strokes are required. This product, thanks to its versatility, the vast variety of accessories, the various bore sizes combined with mechanical shock-absorbers, complies perfectly with the requirements of the industry.

TECHNICAL CHARACTERISTICS

Operating pressure: 1,5 ÷ 10 bar
 Ambient temperature: - 20 ÷ 80°C
 Fluid: Filtered air, with or without lubrication

Construction details

Barrel profile of extruded aluminium alloy, internally and externally anodized (15 - 18 µ).
 Removable end-caps for easy inspection.
 Piston fitted with permanent plastoferrite magnetic ring (upon request; bore sizes 16 ÷ 100)
 Piston seals produced in a special nitrile compound self-compensate against wear.
 Rolled stainless steel rod (AISI 303) with female thread (male thread upon request).
 Self-lubricating guide bearings.
 With mechanical end stroke shock-absorbers
 Magnetic switch Series DH... or flush-mounted magnetic sensor DF... series (Section Accessories page 2-3)

Nominal tolerance on stroke

Cyl. Ø	Tolerance mm
12 ÷ 25	+ 1,5/0
32 ÷ 50	+ 2/0
63 ÷ 100	+ 2,5/0

Upon request

- Rear trunnion (page 64)
- Nipple
- Non-rotating piston rod (bore sizes Ø 16 ÷ 100) (page 60-61)
- Hollow through piston rod (bore sizes Ø 20 ÷ 100)
- Magnetic option (bore sizes Ø 16 ÷ 100)
- Tandem cylinders (page 64)
- Slide units, bore sizes Ø 20 ÷ 80 (Section High-Tech page 47)

Developed forces

Calculated by applying the following formula:

Thrust force	Traction force
$Thf = S \cdot p - a$	$Tf = s \cdot p - a$

where: p = supply pressure
 S = piston push surface (cm²)
 s = piston pull surface (cm²)
 a = friction (10%)

Cyl. Ø	Piston rod Ø (mm)	S (cm²)	s (cm²)	Max. reaction of the springs (N)
12	6	1,1	0,8	6,8
16	6	2	1,7	7,8
20	10	3,1	2,3	13,2
25	10	4,9	4,1	19,6
32	12	8	6,9	35,3
40	16	12,6	10,6	45
50	16	19,6	17,6	70,5
63	20	31,1	28	96
80	25	50,3	54,3	119,5
100	25	78,5	73,6	237,2



Codification key

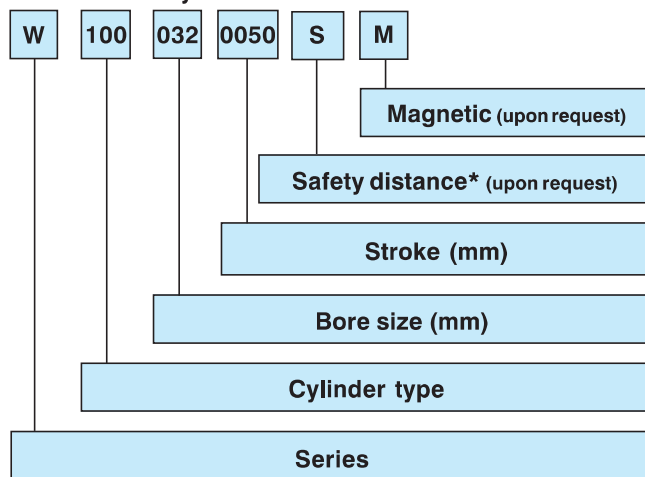

CYLINDER TYPE

- 100 D.A. Double-acting cylinder
- 101 D.A. Double-acting cylinder-through piston rod
- 110 D.A. Double-acting cylinder-non-rotating piston rod*
- 111 D.A. Double-acting cylinder-through, non-rotating piston rod*
- 131 D.A. Double-acting cylinder- hollow through piston rod (min. Ø 20 mm)
- 160 S.A. Single-acting cylinder-retracted piston rod
- 170 S.A. Single-acting cylinder-extended piston rod

VERSION WITH REAR MALE HINGE

(except for bore size Ø 12)

- 700 D.A. Double-acting cylinder
- 760 S.A. Single-acting cylinder - retracted piston rod
- 770 S.A. Single-acting cylinder - extended piston rod

BORE

12 - 16 - 20 - 25 - 32 - 40 - 50 - 63 - 80 - 100 mm

STANDARD STROKE

- Ø 12 - 25 S.A.: 5 - 10 mm
- Ø 32 - 100 S.A.: 5 - 10 - 25 mm
- Ø 12 - 16 D.A.: 5 - 10 - 20 - 25 - 30 - 40 - 50 mm
- Ø 20 - 100 D.A.: 5 - 10 - 20 - 25 - 30 - 40 - 50 - 75 mm

* The cylinder types without safety distance requested by the customer have to be installed by the user in accordance with EC rules EN 294 (page 90-91).



Double-acting cylinder W 100 . . / W 100 . . M Series

Ø 12 mm cylinder

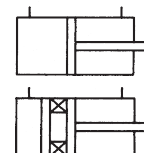
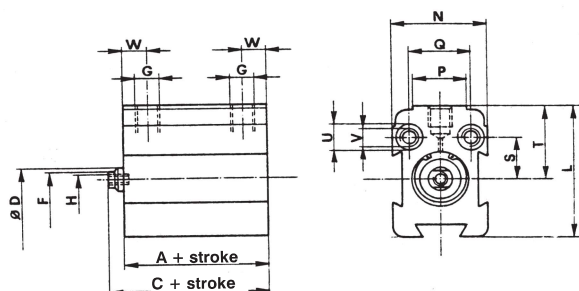

Ø 16 ÷ 100 cylinder

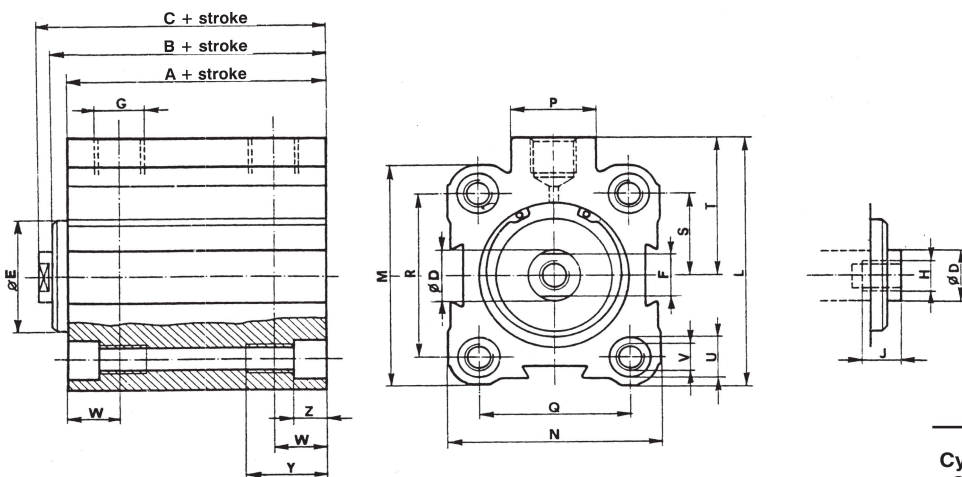

Mass

Cyl. Ø	Stroke 0 non magnetic kg	Stroke 0 magnetic kg	Increase per mm (g)
12	0,045	-	1,2
16	0,074	0,102	1,4
20	0,095	0,12	2
25	0,1355	0,155	2,85
32	0,233	0,292	4,06
40	0,394	0,43	5,47
50	0,39	0,446	6,4
63	0,64	0,772	9,7
80	1,19	1,275	14,85
100	1,72	1,92	19,7

Cyl. Ø	A	B	C	A*	B*	C*	D	E	F	G	H	J	L	M	N	P	Q	R	S	T	U	V		W	Y	Z
																						hole	thread			
12	32	-	35,5	-	-	-	6	-	5	M5	M3	6,5	28,5	-	20	11	13	-	9	16	6	3,7	M4	8,2	9	3,4
16	32	-	35,5	42	-	45,5	6	-	5	M5	M3	6,5	31	28	28	11	20	20	10	17	5,8	3,7	M4	6,5	9	3,4
20	35	-	42	45	-	52	10	-	8	M5	M5	10	35	32	32	11	22	22	11	19	7,5	4,6	M5	7	10	4,6
25	35	-	42	45	-	52	10	-	8	G 1/8	M5	10	44,5	39	37	18	26	28	14	25	7,5	4,6	M5	7,5	10	4,6
32	37	42	49	47	52	59	12	23	10	G 1/8	M6	12	54	48	45	18	32	36	18	30	8,5	5,55	M6	9	16	5,7
40	40	47	55	45	52	60	16	29,5	13	G 1/8	M8	14	60	54,5	54,5	18	40	40	20	33	8,5	5,55	M6	9,5	16	5,7
50	40	46,5	55	45	51,5	60	16	35,5	13	G 1/4	M8	14	72	64	64	22	50	50	25	40	10,5	7,4	M8	10	16	6,8
63	42	50,5	59	47	55,5	64	20	43	17	G 1/4	M10	15	88	80	80	22	62	62	31	48	13,5	9,3	M10	10	20	9
80	52	60	71,5	57	65	76,5	25	50	22	G 3/8	M12	20	110	100	100	26	82	82	41	60	13,5	9,3	M10	15	20	9
100	52	60	71,5	57	65	76,5	25	56	22	G 3/8	M12	20	134	124	124	26	103	103	51,5	72	16,5	11,2	M12	15	25	11

* Magnetic version



Double-acting cylinder with through piston rod W 101 .. / W 101 .. M Series

Ø 12 mm cylinder

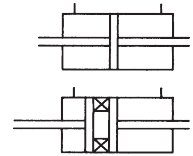
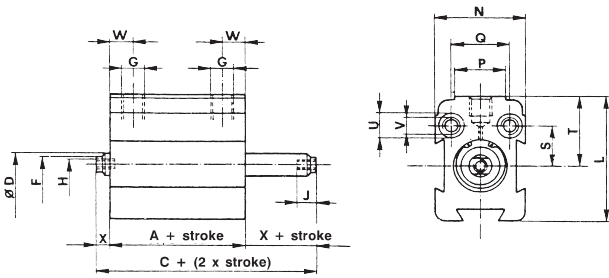

Mass

Cyl. Ø	Stroke 0 non magnetic kg	Stroke 0 magnetic kg	Increase per mm (g)
12	0,055	-	1,4
16	0,086	0,114	1,6
20	0,112	0,137	2,65
25	0,165	0,185	3,5
32	0,295	0,354	5
40	0,5	0,536	7
50	0,478	0,534	8
63	0,79	0,922	12,2
80	1,345	1,43	18,7
100	1,875	2,075	23,6

Ø 16 ÷ 100 mm cylinder

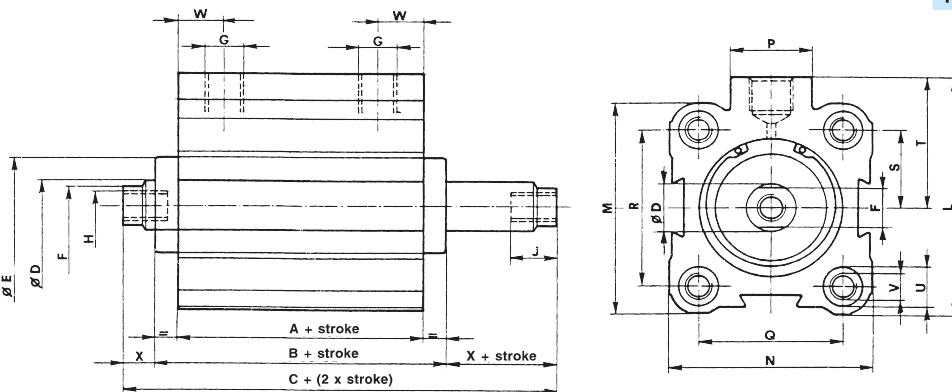

Double-acting cylinder with hollow through piston rod W 131 .. / W 131 .. M Series

(from. Ø 20 ÷ 100 mm)

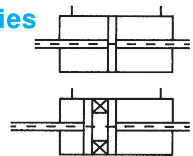
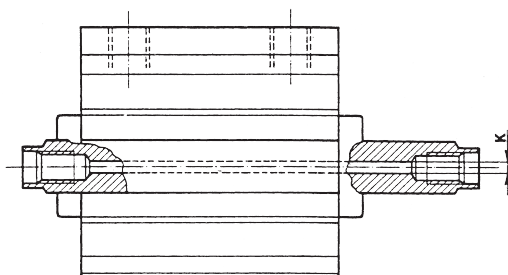

Cyl. Ø	12	16	20	25	32	40	50	63	80	100
K	-	-	2,5	2,5	3	4	4	6	6	6

For weights see table above

Cyl. Ø	A	B	C	A*	B*	C*	D	E	F	G	H	J	L	M	N	P	Q	R	S	T	U	V		W	X	Y	Z
																						hole	thread				
12	37	-	44	-	-	-	6	-	5	M5	M3	6,5	28,5	-	20	11	13	-	9	16	6	3,7	M4	8,2	3,5	9	3,4
16	37	-	44	47	-	54	6	-	5	M5	M3	6,5	31	28	28	11	20	20	10	17	5,8	3,7	M4	6,5	3,5	9	3,4
20	40	-	54	50	-	64	10	-	8	M5	M5	10	35	32	32	11	22	22	11	19	7,5	4,6	M5	7	7	10	4,6
25	40	-	54	50	-	64	10	-	8	G 1/8	M5	10	44,5	39	37	18	26	28	14	25	7,5	4,6	M5	7,5	7	10	4,6
32	42	52	66	52	62	76	12	23	10	G 1/8	M6	12	54	48	45	18	32	36	18	30	8,5	5,55	M6	9	7	16	5,7
40	45	59	75	50	64	80	16	29,5	13	G 1/8	M8	14	60	54,5	54,5	18	40	40	20	33	8,5	5,55	M6	9,5	8	16	5,7
50	45	58	75	50	63	80	16	35,5	13	G 1/4	M8	14	72	64	64	22	50	50	25	40	10,5	7,4	M8	10	8,5	16	6,8
63	47	64	81	52	69	86	20	43	17	G 1/4	M10	15	88	80	80	22	62	62	31	48	13,5	9,3	M10	10	8,5	20	9
80	52	68	91	57	73	96	25	50	22	G 3/8	M12	20	110	100	100	26	82	82	41	60	13,5	9,3	M10	15	11,5	20	9
100	52	68	91	57	73	96	25	56	22	G 3/8	M12	20	134	124	124	26	103	103	51,5	72	16,5	11,2	M12	15	11,5	25	11

* Magnetic version



Single-acting cylinder, with retracted piston rod W 160 . . / W 160 . . M series
 Ø 12 mm cylinder

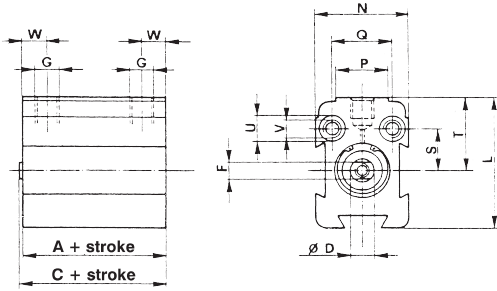
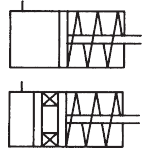

Ø 16 ÷ 100 mm cylinder

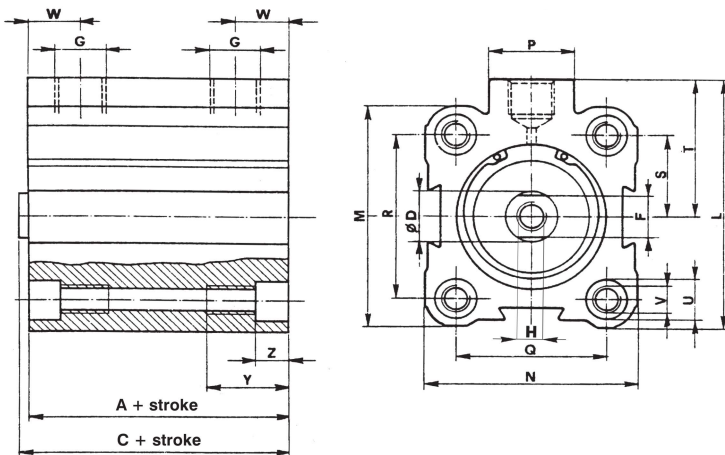

Mass

Cyl. Ø	Stroke 0 non magnetic kg	Stroke 0 magnetic kg	Increase per mm (g)
12	0,038	-	1,2
16	0,059	0,079	1,4
20	0,07	0,095	2
25	0,096	0,116	2,85
32	0,194	0,253	4,06
40	0,326	0,362	5,47
50	0,322	0,378	6,4
63	0,533	0,715	9,7
80	1,02	1,105	14,85
100	1,49	1,69	19,7

Cyl. Ø	A	C	A*	C*	D	F	G	H	J	L	M	N	P	Q	R	S	T	U	V		W	Y	Z
																			hole	thread			
12	27	28	-	-	6	5	M5	M3	6,5	28,5	-	20	11	13	-	9	16	6	3,7	M4	8,2	9	3,4
16	22	23	37	38	6	5	M5	M3	6,5	31	28	28	11	20	20	10	17	5,8	3,7	M4	6,5	9	3,4
20	25	26	40	41	10	8	M5	M5	10	35	32	32	11	22	22	11	19	7,5	4,6	M5	7	10	4,6
25	25	26	40	41	10	8	G 1/8	M5	10	44,5	39	37	18	26	28	14	25	7,5	4,6	M5	7,5	10	4,6
32	32	33	47	48	12	10	G 1/8	M6	12	54	48	45	18	32	36	18	30	8,5	5,55	M6	9	16	5,7
40	35	36	45	46	16	13	G 1/8	M8	14	60	54,5	54,5	18	40	40	20	33	8,5	5,55	M6	9,5	16	5,7
50	35	36	45	46	16	13	G 1/4	M8	14	72	64	64	22	50	50	25	40	10,5	7,4	M8	10	16	6,8
63	37	39	47	49	20	17	G 1/4	M10	15	88	80	80	22	62	62	31	48	13,5	9,3	M10	10	20	9
80	47	53	57	63	25	22	G 3/8	M12	20	110	100	100	26	82	82	41	60	13,5	9,3	M10	15	20	9
100	47	53	57	63	25	22	G 3/8	M12	20	134	124	124	26	103	103	51,5	72	16,5	11,2	M12	15	25	11

* Magnetic version



Single-acting cylinder with extended piston rod W 170 .. / W 170 .. M Series

Ø 12 mm cylinder

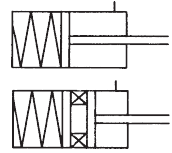
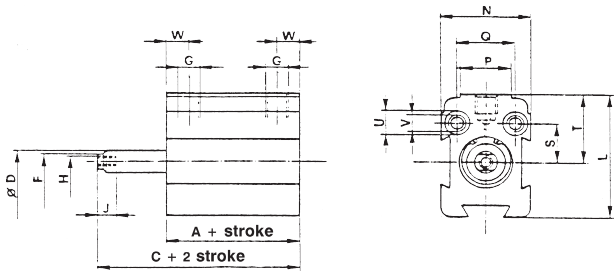

Ø 16 ÷ 100 mm cylinder

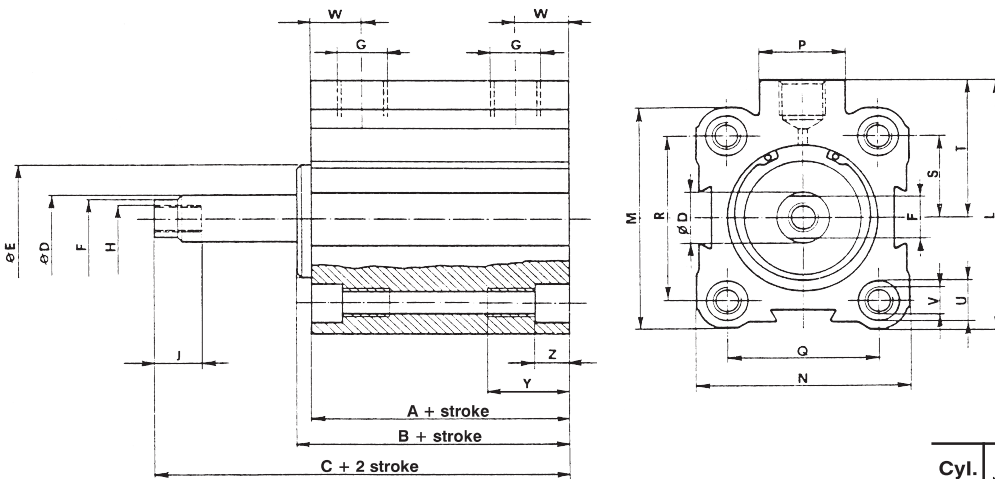

Mass

Cyl. Ø	Stroke 0 non magnetic kg	Stroke 0 magnetic kg	Increase per mm (g)
16	0,7	0,098	1,4
20	0,86	0,111	2
25	0,122	0,142	2,85
32	0,212	0,271	4,06
40	0,366	0,402	5,47
50	0,352	0,408	6,4
63	0,59	0,772	9,7
80	1,104	1,189	14,85
100	1,576	1,776	19,7

Cyl. Ø	A	B	C	A*	B*	C*	D	E	F	G	H	J	L	M	N	P	Q	R	S	T	U	V		W	Y	Z
																						hole	thread			
12	32	-	35,5	-	-	-	6	-	5	M5	M3	6,5	28,5	-	20	11	13	-	9	16	6	3,7	M4	8,2	9	3,4
16	27	-	30,5	42	-	45,5	6	-	5	M5	M3	6,5	31	28	28	11	20	20	10	17	5,8	3,7	M4	6,5	9	3,4
20	30	-	37	45	-	52	10	-	8	M5	M5	10	35	32	32	11	22	22	11	19	7,5	4,6	M5	7	10	4,6
25	30	-	37	45	-	52	10	-	8	G 1/8	M5	10	44,5	39	37	18	26	28	14	25	7,5	4,6	M5	7,5	10	4,6
32	32	37	44	47	52	59	12	23	10	G 1/8	M6	12	54	48	45	18	32	36	18	30	8,5	5,55	M6	9	16	5,7
40	35	42	50	45	52	60	16	29,5	13	G 1/8	M8	14	60	54,5	54,5	18	40	40	20	33	8,5	5,55	M6	9,5	16	5,7
50	35	41,5	50	45	51,5	60	16	35,5	13	G 1/4	M8	14	72	64	64	22	50	50	25	40	10,5	7,4	M8	10	16	6,8
63	37	45,5	54	47	55,5	64	20	43	17	G 1/4	M10	15	88	80	80	22	62	62	31	48	13,5	9,3	M10	10	20	9
80	47	55	66,5	57	65	76,5	25	50	22	G 3/8	M12	20	110	100	100	26	82	82	41	60	13,5	9,3	M10	15	20	9
100	47	55	66,5	57	65	76,5	25	56	22	G 3/8	M12	20	134	124	124	26	103	103	51,5	72	16,5	11,2	M12	15	25	11

* Magnetic version

Non-rotating piston rod
W 110 .. / W 110 .. M Series

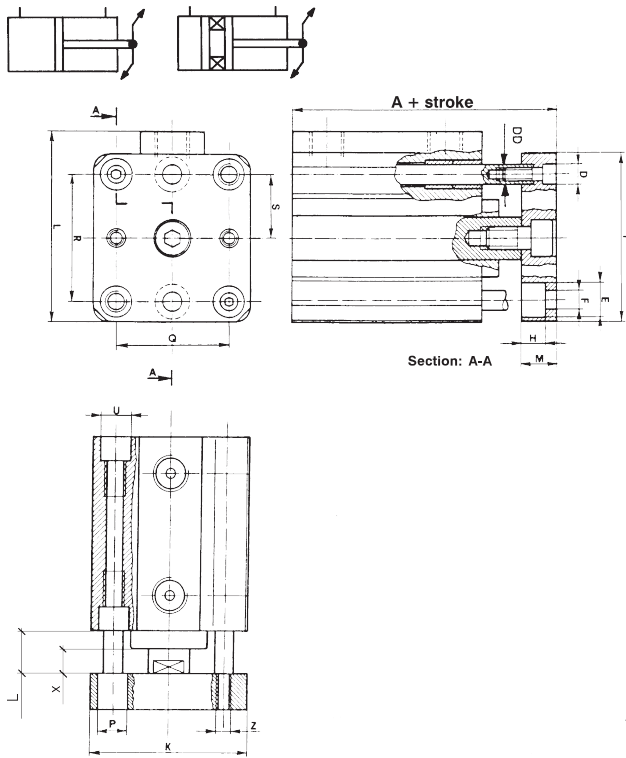

Non-rotating through piston rod
W 111 .. / W 111 .. M Series

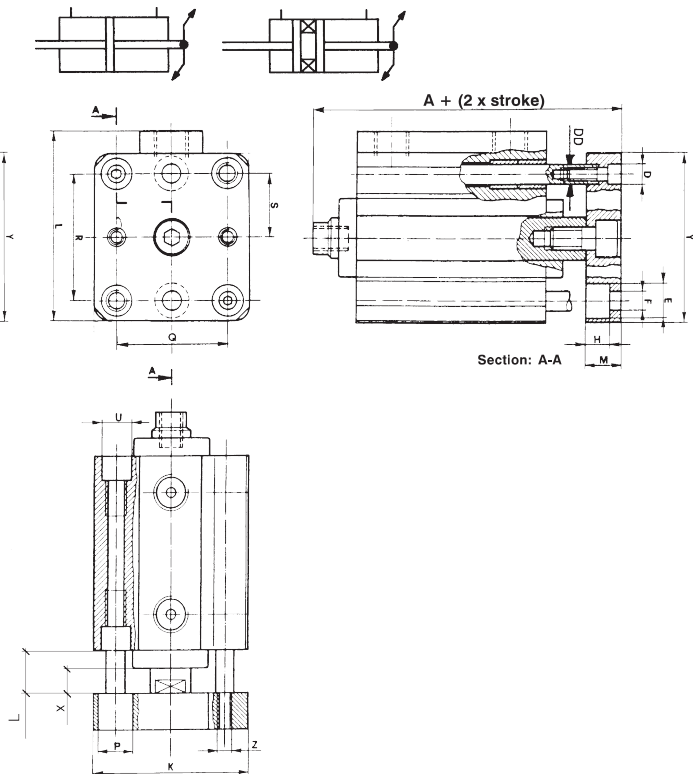

Non-rotating piston rod
W 110 .. S / W 110 .. SM Series

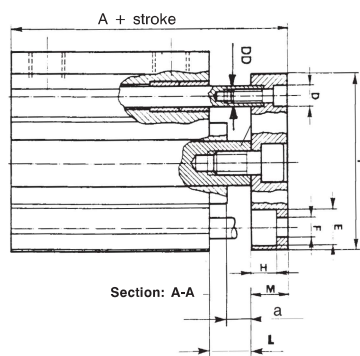
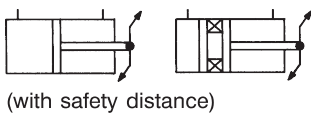

Non-rotating through piston rod
W 111 .. S / W 111 .. SM Series

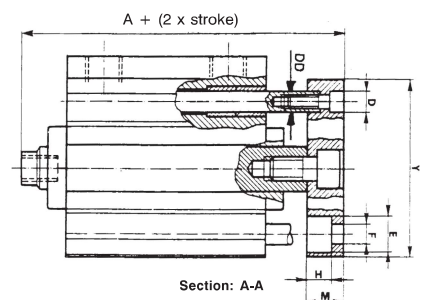
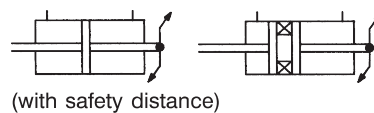

Mass

Cyl. Ø	Stroke 0 non magnetic kg	Stroke 0 magnetic kg	Increase per mm (g)
16	0,092	0,12	1,6
20	0,133	0,158	2,45
25	0,185	0,205	3,3
32	0,33	0,39	4,85
40	0,545	0,58	6,7
50	0,6	0,656	7,6
63	0,96	1,092	11,5
80	1,75	1,835	17,25
100	2,63	2,83	22,8

Mass

Cyl. Ø	Stroke 0 non magnetic kg	Stroke 0 magnetic kg	Increase per mm (g)
16	0,104	0,132	1,8
20	0,15	0,175	3,1
25	0,214	0,234	3,95
32	0,392	0,452	5,8
40	0,651	0,686	8,2
50	0,688	0,744	9,2
63	1,11	1,242	14
80	1,905	1,99	21
100	2,785	2,985	26,7

Chart relating to load / protrusion

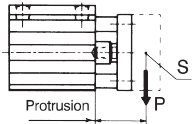

S = point of application of load
P = load (N)

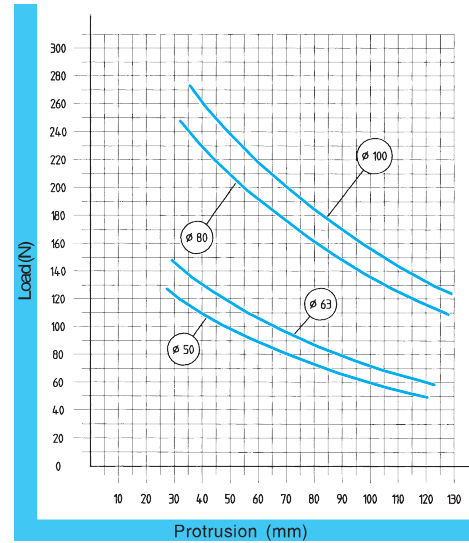
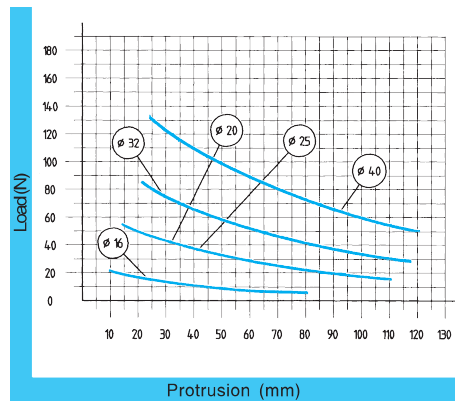

Overall dimensions of non-rotating cylinders

Cyl. Ø	X	L	W110 A + stroke	W111 A + (2 x stroke)	W110M A* + stroke	W111M A* + (2 x stroke)	D	DD	E	F	H	K	M	P	Q	R	S	Y	Z
16	3,5	3,5	42,5	51	52,5	61	6	4	6	3,5	3,5	27,5	7	6	20	20	10	27,5	M3
20	7	7	50	62	60	72	7,5	6	7,5	4,5	4,5	31,5	8	7,5	22	22	11	31,5	M4
25	7	7	50	62	60	72	7,5	6	7,5	4,5	5	36	8	7,5	26	28	14	38	M4
32	7	12	59	76	69	86	9	8	10	5,5	6	44,5	10	10	32	36	18	47,5	M4
40	8	15	65	85	70	90	10,5	10	10	5,5	6	53,5	10	10	40	40	20	53,5	M5
50	8,5	15	67	87	72	92	10,5	10	11	6,5	7	63,5	12	11	50	50	25	63,5	M6
63	8,5	17	71	93	76	98	13,5	12	14	9	9	79,5	12	15	62	62	31	79,5	M6
80	11,5	19,5	85,5	105	90,5	110	13,5	14	14	9	9	99,5	14	15	82	82	41	99,5	M8
100	11,5	19,5	87,5	107	92,5	112	16,5	16	16,5	10,5	10,5	123,5	16	17	103	103	51,5	123,5	M8

* Magnetic version

Overall dimensions of cylinder with non-rotating piston rod and safety distance option

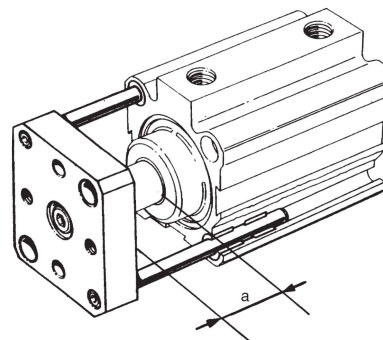

Cyl. Ø	W110 A + stroke	W111 A + (2 x stroke)	W110M A* + stroke	W111M A* + (2 x stroke)	L	a
16	67,5	76	77,5	86	28,5	28,5
20	70	82	80	92	27	27
25	70	82	80	92	27	27
32	79	96	89	106	32	27
40	85	105	90	110	35	28
50	87	107	92	112	35	28,5
63	91	113	96	118	37	28,5
80	100,5	120	105,5	125	34,5	26,5
100	102,5	122	107,5	127	34,5	26,5

Accident prevention safety distance in accordance with EC rules EN 294 to be provided by the user.

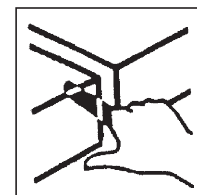

* Magnetic version

NOTE: for additional dimensions, please refer to models without non-rotating device



Tandem cylinder

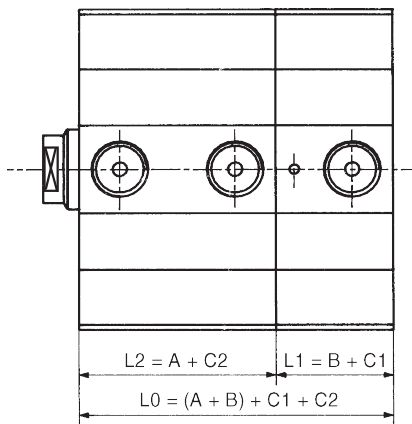
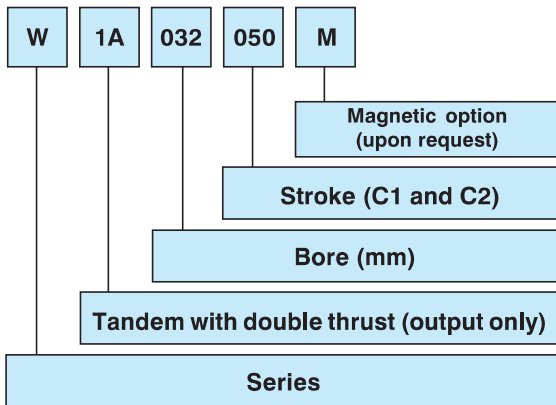
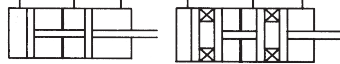

Tandem short stroke "W series"

Vér. Ø	L2 = A + C2	L1 = B + C1	L0 = (A+B) + C1 + C2
16	L2 = 37 + C2	L1 = 22 + C1	L0 = 59 + C1 + C2
20	L2 = 40 + C2	L1 = 25 + C1	L0 = 65 + C1 + C2
25	L2 = 40 + C2	L1 = 25 + C1	L0 = 65 + C1 + C2
32	L2 = 42 + C2	L1 = 23 + C1	L0 = 65 + C1 + C2
40	L2 = 45 + C2	L1 = 26,5 + C1	L0 = 71,5 + C1 + C2
50	L2 = 45 + C2	L1 = 26 + C1	L0 = 71 + C1 + C2
63	L2 = 47 + C2	L1 = 29 + C1	L0 = 76 + C1 + C2
80	L2 = 52 + C2	L1 = 38 + C1	L0 = 90 + C1 + C2
100	L2 = 52 + C2	L1 = 38 + C1	L0 = 90 + C1 + C2

Tandem short stroke "W series" magnetic

Cyl. Ø	L2 = A + C2	L1 = B + C1	L0 = (A+B) + C1 + C2
16	L2 = 47 + C2	L1 = 37 + C1	L0 = 84 + C1 + C2
20	L2 = 50 + C2	L1 = 40 + C1	L0 = 90 + C1 + C2
25	L2 = 50 + C2	L1 = 40 + C1	L0 = 90 + C1 + C2
32	L2 = 52 + C2	L1 = 38 + C1	L0 = 90 + C1 + C2
40	L2 = 50 + C2	L1 = 36,5 + C1	L0 = 86,5 + C1 + C2
50	L2 = 50 + C2	L1 = 36 + C1	L0 = 86 + C1 + C2
63	L2 = 52 + C2	L1 = 39 + C1	L0 = 91 + C1 + C2
80	L2 = 57 + C2	L1 = 48 + C1	L0 = 105 + C1 + C2
100	L2 = 57 + C2	L1 = 48 + C1	L0 = 105 + C1 + C2

Tandem cylinder with two positions

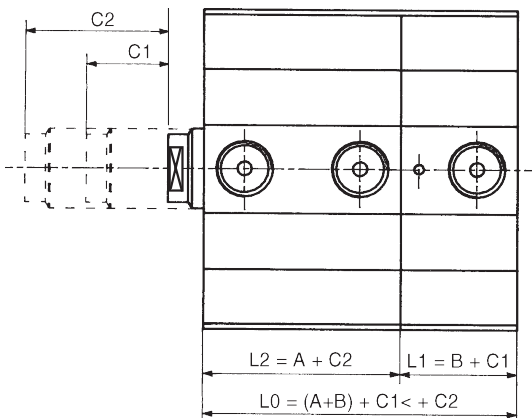
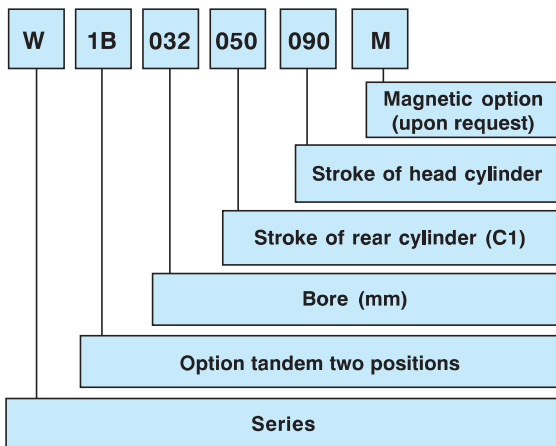

Stroke C1 is always lower than stroke C2

Tandem short stroke two positions "W series"

Cyl. Ø	L2 = A + C2	L1 = B + C1	L0 = (A+B) + C1 + C2
16	L2 = 37 + C2	L1 = 22 + C1	L0 = 59 + C1 + C2
20	L2 = 40 + C2	L1 = 25 + C1	L0 = 65 + C1 + C2
25	L2 = 40 + C2	L1 = 25 + C1	L0 = 65 + C1 + C2
32	L2 = 42 + C2	L1 = 23 + C1	L0 = 65 + C1 + C2
40	L2 = 45 + C2	L1 = 26,5 + C1	L0 = 71,5 + C1 + C2
50	L2 = 45 + C2	L1 = 26 + C1	L0 = 71 + C1 + C2
63	L2 = 47 + C2	L1 = 29 + C1	L0 = 76 + C1 + C2
80	L2 = 52 + C2	L1 = 38 + C1	L0 = 90 + C1 + C2
100	L2 = 52 + C2	L1 = 38 + C1	L0 = 90 + C1 + C2

Tandem short stroke two positions "W series" magnetic

Cyl. Ø	L2 = A + C2	L1 = B + C1	L0 = (A+B) + C1 + C2
16	L2 = 47 + C2	L1 = 37 + C1	L0 = 84 + C1 + C2
20	L2 = 50 + C2	L1 = 40 + C1	L0 = 90 + C1 + C2
25	L2 = 50 + C2	L1 = 40 + C1	L0 = 90 + C1 + C2
32	L2 = 52 + C2	L1 = 38 + C1	L0 = 90 + C1 + C2
40	L2 = 50 + C2	L1 = 36,5 + C1	L0 = 86,5 + C1 + C2
50	L2 = 50 + C2	L1 = 36 + C1	L0 = 87 + C1 + C2
63	L2 = 52 + C2	L1 = 39 + C1	L0 = 91 + C1 + C2
80	L2 = 57 + C2	L1 = 48 + C1	L0 = 105 + C1 + C2
100	L2 = 57 + C2	L1 = 48 + C1	L0 = 105 + C1 + C2

Multiple position cylinder WS (see drawing for references)

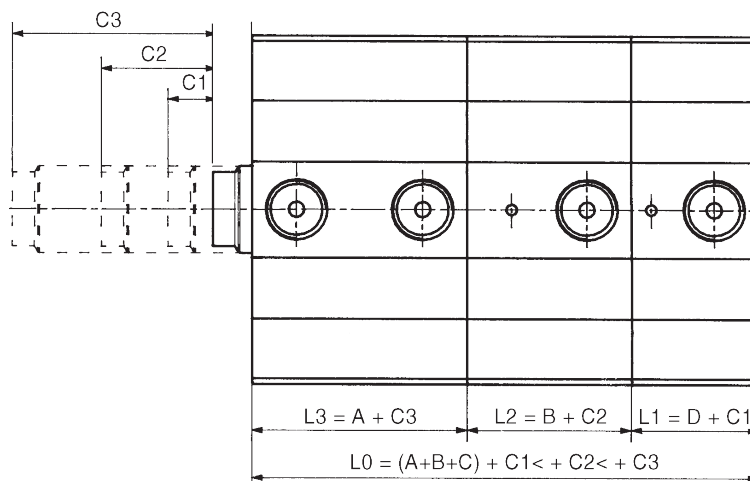
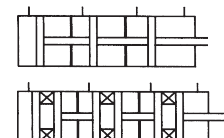

Multiple position tandem short stroke "W series"

Cyl. Ø	$L3 = A + C3$	$L2 = B + C2$	$L1 = D + C1$	$L0 = (A+B+D) + C1< + C2< + C3$
16	$L3 = 37 + C3$	$L2 = 27 + C2$	$L1 = 22 + C1$	$L0 = 86 + C1< + C2< + C3$
20	$L3 = 40 + C3$	$L2 = 30 + C2$	$L1 = 25 + C1$	$L0 = 95 + C1< + C2< + C3$
25	$L3 = 40 + C3$	$L2 = 30 + C2$	$L1 = 25 + C1$	$L0 = 95 + C1< + C2< + C3$
32	$L3 = 42 + C3$	$L2 = 28 + C2$	$L1 = 23 + C1$	$L0 = 93 + C1< + C2< + C3$
40	$L3 = 45 + C3$	$L2 = 31.5 + C2$	$L1 = 26.5 + C1$	$L0 = 103 + C1< + C2< + C3$
50	$L3 = 45 + C3$	$L2 = 31 + C2$	$L1 = 26 + C1$	$L0 = 102 + C1< + C2< + C3$
63	$L3 = 47 + C3$	$L2 = 36 + C2$	$L1 = 29 + C1$	$L0 = 112 + C1< + C2< + C3$
80	$L3 = 52 + C3$	$L2 = 38 + C2$	$L1 = 38 + C1$	$L0 = 128 + C1< + C2< + C3$
100	$L3 = 52 + C3$	$L2 = 38 + C2$	$L1 = 38 + C1$	$L0 = 128 + C1< + C2< + C3$

Multiple position tandem short stroke "W series" magnetic

Cyl. Ø	$L3 = A + C3$	$L2 = B + C2$	$L1 = D + C1$	$L0 = (A+B+D) + C1< + C2< + C3$
16	$L3 = 47 + C3$	$L2 = 42 + C2$	$L1 = 37 + C1$	$L0 = 126 + C1< + C2< + C3$
20	$L3 = 50 + C3$	$L2 = 45 + C2$	$L1 = 40 + C1$	$L0 = 135 + C1< + C2< + C3$
25	$L3 = 50 + C3$	$L2 = 45 + C2$	$L1 = 40 + C1$	$L0 = 135 + C1< + C2< + C3$
32	$L3 = 52 + C3$	$L2 = 43 + C2$	$L1 = 38 + C1$	$L0 = 133 + C1< + C2< + C3$
40	$L3 = 50 + C3$	$L2 = 41.5 + C2$	$L1 = 36.5 + C1$	$L0 = 128 + C1< + C2< + C3$
50	$L3 = 50 + C3$	$L2 = 41 + C2$	$L1 = 36 + C1$	$L0 = 127 + C1< + C2< + C3$
63	$L3 = 52 + C3$	$L2 = 44 + C2$	$L1 = 39 + C1$	$L0 = 135 + C1< + C2< + C3$
80	$L3 = 57 + C3$	$L2 = 48 + C2$	$L1 = 48 + C1$	$L0 = 153 + C1< + C2< + C3$
100	$L3 = 57 + C3$	$L2 = 48 + C2$	$L1 = 48 + C1$	$L0 = 153 + C1< + C2< + C3$

NOTE: options with non-rotating rod are possible
 Additional dimensions are reported in W100 ... series at page 56



Rear male hinge

W 700 ... / W 700 ... M series

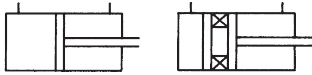

W 760 ... / W 760 ... M series

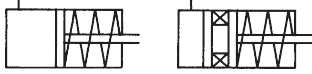

W 770 ... / W 770 ... M series

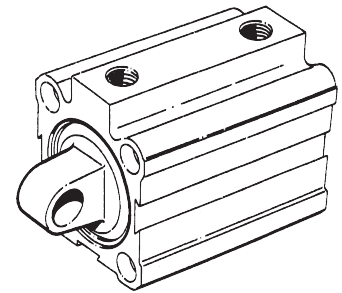
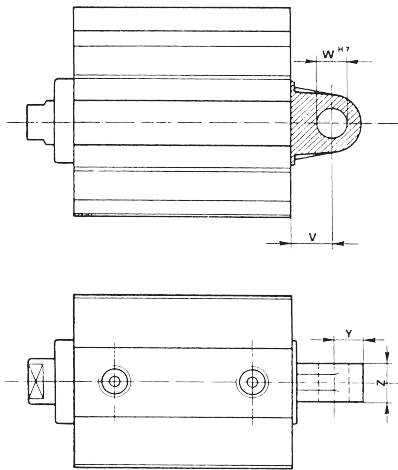
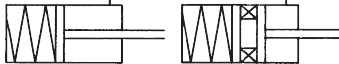

Mass

Cyl. Ø	W700.../W700...M			W760.../W760...M			W770.../W770...M		
	Stroke 0 non magnetic kg	Stroke 0 magnetic kg	Increase per mm (g)	Stroke 0 non magnetic kg	Stroke 0 magnetic kg	Increase per mm (g)	Stroke 0 non magnetic kg	Stroke 0 magnetic kg	Increase per mm (g)
12	-	-	-	-	-	-	-	-	-
16	0,082	0,11	1,4	0,067	0,087	1,4	0,078	0,106	1,4
20	0,1075	0,1325	2	0,0825	0,0975	2	0,0985	0,1235	2
25	0,1585	0,1785	2,85	0,119	0,139	2,85	0,145	0,165	2,85
32	0,2765	0,3355	4,06	0,2375	0,2965	4,06	0,2555	0,3155	4,06
40	0,4705	0,5065	5,47	0,4025	0,4385	5,47	0,442	0,4785	5,47
50	0,417	0,473	6,4	0,349	0,405	6,4	0,379	0,435	6,4
63	0,6815	0,8135	9,7	0,5745	0,7565	9,7	0,6315	0,9135	9,7
80	1,2385	1,3235	14,85	1,0685	1,1535	14,85	1,1525	1,2375	14,85
100	1,775	1,975	19,7	1,545	1,745	19,7	1,631	1,831	19,7

Cyl. Ø	Y	Z	Ø W ^{H7}	V
12	-	-	-	-
16	5,5	9	6 ^{H7}	6,2
20	5,5	9	6 ^{H7}	6,5
25	6	12	6 ^{H7}	8
32	9	14	10 ^{H7}	11
40	10	16	12 ^{H7}	13
50	12	17	12 ^{H7}	16,5
63	14	21	16 ^{H7}	18
80	14	21	16 ^{H7}	16,5
100	17	25	20 ^{H7}	21

Fixing screws

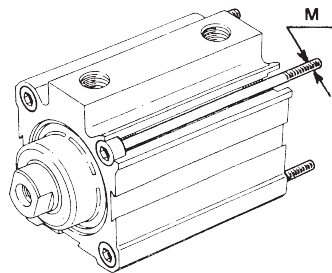

Cyl. Ø	12	16*	20	25	32	40	50	63	80	100
M	3	3	4	4	5	5	6	8	8	10

* Magnetic version only for bore 16, the fixing screws have to be of the non magnetic type.

Nipple

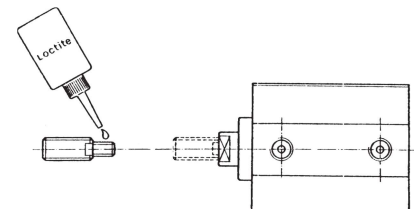
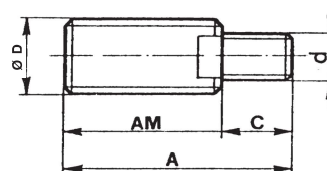

Cyl. Ø	A	AM	C	D	d	Part number
12-16	22,5	16	6,5	6 x 1	M 3	WF-50012
20-25	30	20	10	8 x 1,25	M 5	WF-50020
32	34	22	12	10 x 1,25	M 6	WF-50032
40	38	24	14	12 x 1,25	M 8	WF-50040
50	46	32	14	16 x 1,5	M 8	WF-50050
63	47	32	15	16 x 1,5	M 10	WF-50063
80-100	60	40	20	20 x 1,5	M 12	WF-50080