

**Slide units for pneumatic cylinder suitable for:**

<p><b>ISO 6431 - 6432 cylinders</b>  <b>M series</b>                  Ø 16 ÷ 25  <b>K/KD series</b>                  Ø 32 ÷ 100</p>	<p><b>Slide units for rodless cylinders</b>  <b>S1 series</b>                  Ø 25 ÷ 50</p>	<p><b>Short-stroke cylinders</b>  <b>W series</b>                  Ø 25 ÷ 100</p>	<p><b>Compact cylinders</b>  <b>STRONG</b>  <b>RS series</b>                  Ø 32 ÷ 63</p>	<p><b>2-stage telescopic cylinders</b>  <b>RT2 series</b>                  Ø 32 ÷ 63</p>
---	--	---	---	--

**CONSTRUCTION CHARACTERISTICS**

**Enlarged chromium-plated hollow guides provide robustness and reliability**

**An economical solution thanks to the components used which ensure long life (7000 – 10000 km)**

**Special metallic self-lubricating bearings, minimizing noise and abrasion**

**Customized slide units available upon request**

**High resistance to peak loads.  
 Scraper bearings standard supplied for J10-.../J31-... series**

**All models available with safety distance 25 mm for accident prevention according to EC rules EN 349**

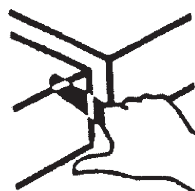

**TECHNICAL CHARACTERISTICS**

Working pressure:

2 ÷ 10 bar	3 ÷ 10 bar	2 ÷ 10 bar	2 ÷ 10 bar	2 ÷ 10 bar
------------	------------	------------	------------	------------

Ambient temperature:

**- 20°C ÷ 80°C**

**SIZES**

16 ÷ 100	40 ÷ 80	25 ÷ 100	32 ÷ 63	32 ÷ 63
----------	---------	----------	---------	---------

**STANDARD STROKES (mm)**

25 ÷ 1000	up to 800 mm max	5 ÷ 75	15 ÷ 800	120 ÷ 1200
-----------	------------------	--------	----------	------------

**For min. and max. strokes refer to respective codification key.**

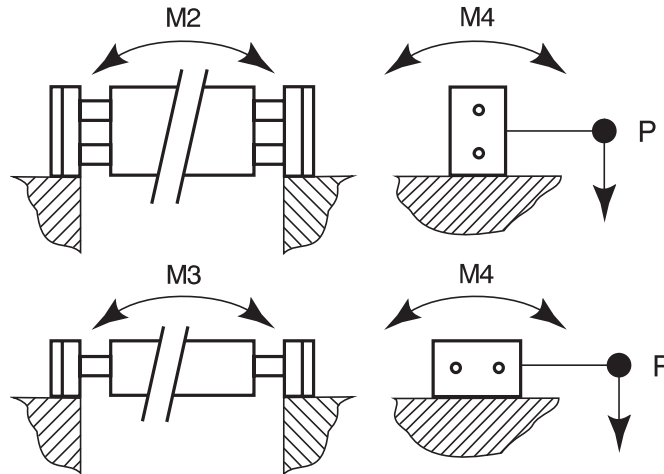

Slide units for ISO 6431 - 6432 cylinder

Size slide unit	J17=J17B M2 (Nm)								J17=J17B M3 (Nm)								M4 (Nm)
	Stroke (m/m)																
	100	200	300	400	500	750	1000	100	200	300	400	500	750	1000			
16	30,4	48,4	58	84,8	103	148,8	194,8	29	47,4	70	84,2	102,6	148,6	194,6	9,4		
25	56,8	114	114	143,2	172,4	246	320	53	82,6	112	141,8	171,4	245,4	320	20,4		
32	89,4	133	178	222	270	386	502	80	126,8	173,6	220	267,2	384	500	39,8		
40	117	169,2	223,6	279	334,4	474,8	616	104	160,6	217,4	274	330	472	614	53,8		
50	161,4	230	301,4	373,2	446	630	816	138	212,8	287,2	361,6	436	622	808	85,6		
63	228	312	402	493	586	818	1102	192,8	288	383	478	573	810	1048	123,4		
80	328,6	434	550,4	668	788,8	1091,2	1398	270	394	518	642	766	1076	1386	186		
100	349,6	456	570	687	806	1108,6	1414	284	408	532	656	780	1090	1400	203,2		

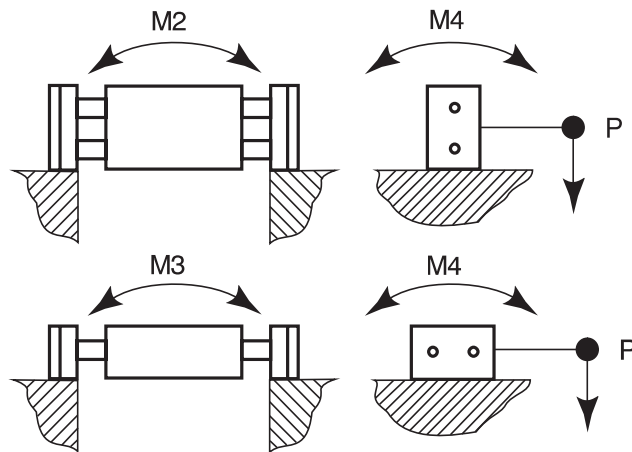

Slide units for rodless cylinder

Size slide unit	Cylinder bore (mm)	Standard carriage J30		Long carriage J31		M4 (Nm)
		M2 (Nm)	M3 (Nm)	M2 (Nm)	M3 (Nm)	
40	25	68,4	42,4	110,2	96,2	53,8
50	32	118,4	81,8	198	178,6	85,6
63	40	192,2	147,2	315	289,8	123,4
80	50	298,2	233,2	516	481,2	186

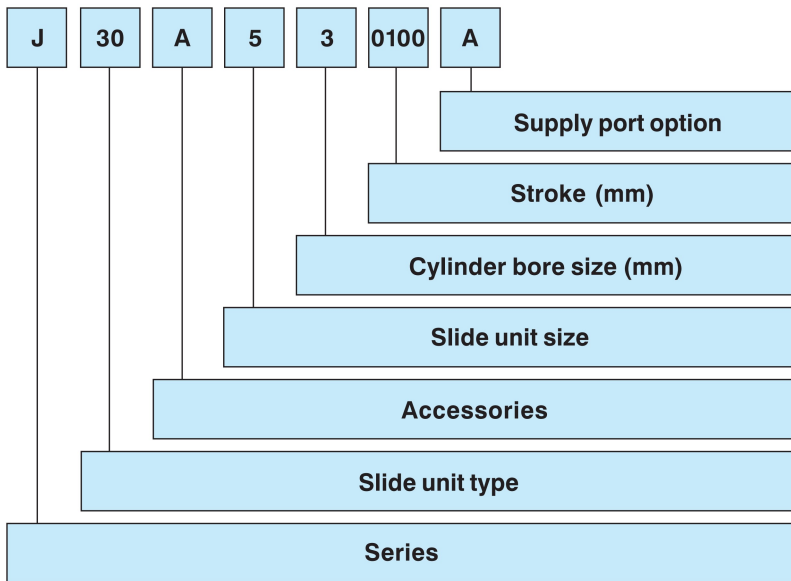

The slide units are supplied with safety distance (+ 25 mm) for accident prevention according to the European EN 349 specifications.

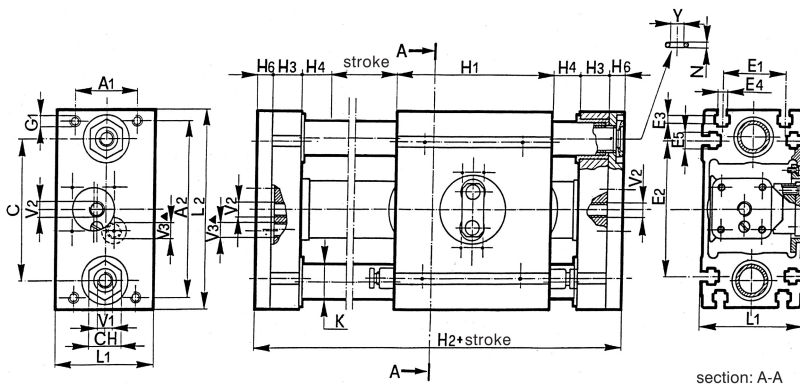

**SERIES**

J = Slide unit Series

**SLIDE UNIT TYPE**

- 30 = Slide unit with fully protected cylinder (2 bearings - standard carriage)
- 31 = Slide unit with fully protected cylinder (2 bearings - long carriage)

**ACCESSORIES**

A = scraper bearings

**SLIDE UNIT SIZE**

- 4 = 40 only for Ø 25 cylinder
- 5 = 50 only for Ø 32 cylinder
- 6 = 63 only for Ø 40 cylinder
- 7 = 80 only for Ø 50 cylinder

**CYLINDER BORE SIZE**

- 2 = 25
- 3 = 32
- 4 = 40
- 5 = 50

**SLIDE UNIT STROKE**

Length in mm up to 800 mm max.

**SUPPLY PORT OPTIONS**

- A = Supply ports on both end-caps
- B = Supply ports on right end-cap only (DX)

**N.B.:** on the 4 sides the plates for sizes 63 - 80 - 100 have chamfers as indicated in the following table:

Bore size Slide unit Cylinder		A1	A2	C	CH	E1	E2	E3	E4	E5	G1	K	Carriage type			
													H1		H2 + stroke	
													Standard	Long	Standard	Long
40	25	42	118	95	22	42	90	5	6,4	10,4	M6	22	110	205	220+stroke	315+stroke
50	32	48,1	140	115	27	48	110	6,5	8,4	13,4	M8	25	150	280	270+stroke	400+stroke
63	40	56	157,5	130	30	56	120	7,5	10,5	17,5	M8	28	200	350	324+stroke	474+stroke
80	50	65	178	150	32	65	142	8,5	10,5	18	M10	32	240	440	374+stroke	574+stroke

H3	H4	H6	L1	L2	N	Y	V1	V2	V3	Mass (kg) "0" stroke				Mass increase (g) per mm stroke		
										Slide unit		Cylinder		Shafts	Standard carriage	Long carriage
										Standard carriage	Long carriage	Standard carriage	Long carriage			
20	25	10	66	130	2,62	10,78	M5	G 1/8	G 1/8	2,89	3,61	0,707	1,02	2,81	2,14	2,14
25	25	10	84	155	2,62	10,78	G 1/8	G 1/4	G 1/4	4,813	6,243	1,298	1,914	3,71	3,28	3,28
25	25	12	98	176	2,62	10,78	G 1/8	G 3/8	G 3/8	6,54	8,02	2,489	3,685	4,7	5,54	5,54
30	25	12	117	200	2,62	10,78	G 1/8	G 3/8	G 3/8	11,04	14,32	2,489	3,685	5,52	5,54	5,54



**Aluminium foot brackets**

SIZE	A	B	C	D	E	F	G	H	L	Part number
16	52	30	10	26	4	9	20	∅ 4,5	43	JF-13016
25	70	30	10	26	4	9	32	∅ 5,5	57	JF-13025
32	85	35	10	30	5	10	38	∅ 6,5	72	JF-13032
40	92	35	10	30	5	10	42	∅ 6,5	79	JF-13040
50	11	40	15	35	5	12,5	48	∅ 8,5	102	JF-13050
63	13	45	15	40	5	15	56	∅ 10,5	112	JF-13063
80	16	45	15	40	5	15	65	∅ 10,5	135	JF-13080
100	17	45	15	40	5	15	72	∅ 10,5	151	JF-13100

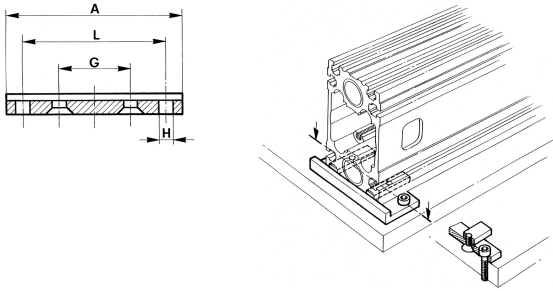

Package consists of 2 pcs. including mounting accessories.

**Fixing plates in steel**

SIZE	A	B	C	D	E	F	Part number
16	3	7	7,5	15	30	M4	JF-42016
25	4	8	10	15	35	M5	JF-42025
32 - 40	4	10	10	20	40	M6	JF-42040
50	6	13	10	30	50	M8	JF-42050
63	6	16	12,5	35	60	M10	JF-42063
80 - 100	8	16	15	40	70	M10	JF-42100

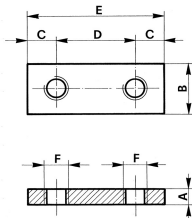

Package consists of 2 pcs. including mounting accessories.

**Shaft support for slide units  
J10/J11/J12 Series**

SIZE	Part number
16	JF-601016
25	JF-601025
32	JF-601032
40	JF-601040
50	JF-601050
63	JF-601063
80	JF-601080
100	JF-601100

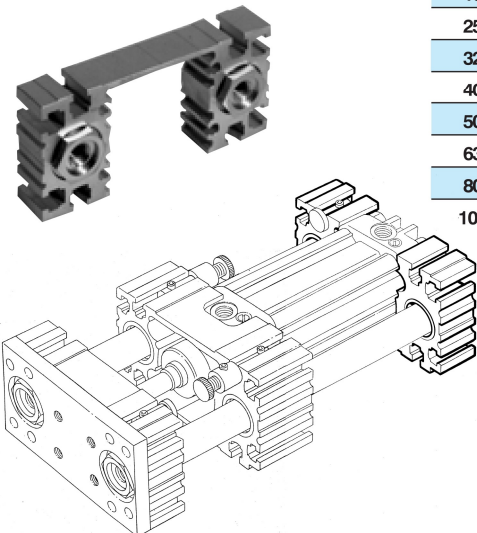

SIZE	A	B	C	D	E	F	G	H	Part number
16	50	30	10	26	3	9	31	∅ 4,5	JF-14016
25	55	30	10	26	3	9	34	∅ 5,5	JF-14025
32	60	35	10	30	4	10	38	∅ 6,5	JF-14032
40	65	35	10	30	4	10	40	∅ 6,5	JF-14040
50	70	40	15	35	4	12,5	45	∅ 8,5	JF-14050
63	85	45	15	40	4	15	56	∅ 10,5	JF-14063
80 - 100	90	45	15	40	4	15	58	∅ 10,5	JF-14100

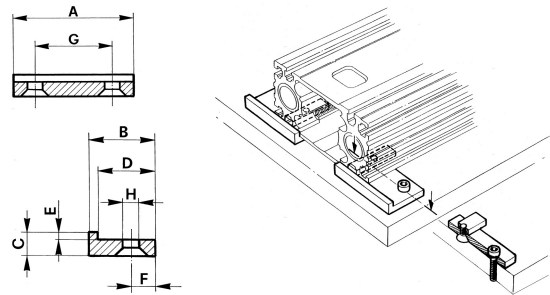

Package consists of 4 pcs. including mounting accessories.

SIZE	A	B	C	D	Part number
16	3	7	16	M4	JF-43016
25	4	8	16	M5	JF-43025
32 - 40	4	10	18	M6	JF-43040
50	6	13	18	M8	JF-43050
63	6	16	22	M10	JF-43063
80 - 100	8	16	25	M10	JF-43100

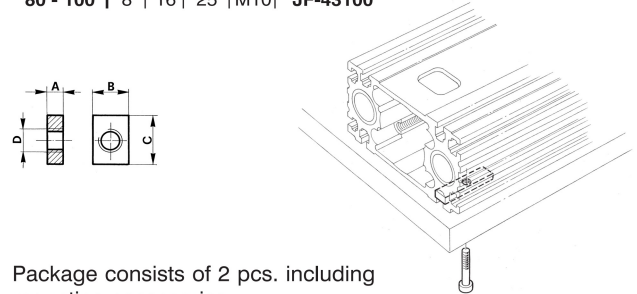

Package consists of 2 pcs. including mounting accessories.

**Scraper bearings**

SIZE	∅ A	Part number
16	12	JF-19016
25	16	JF-19025
32	20	JF-19032
40	22	JF-19040
50	25	JF-19050
63	28	JF-19063
80 - 100	32	JF-19100

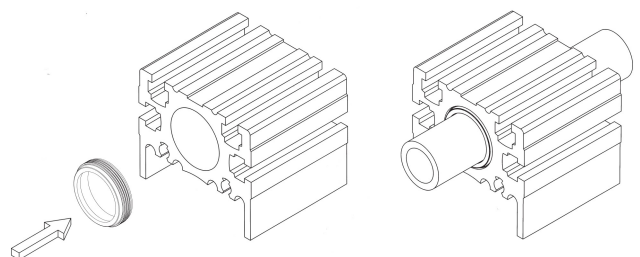
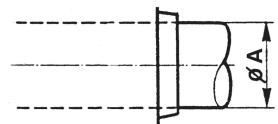

Package comprises 4 pcs.