

Slide units for pneumatic cylinder suitable for:

<p>ISO 6431 - 6432 cylinders M series Ø 16 ÷ 25 K/KD series Ø 32 ÷ 100</p>	<p>Slide units for rodless cylinders S1 series Ø 25 ÷ 50</p>	<p>Short-stroke cylinders W series Ø 25 ÷ 100</p>	<p>Compact cylinders STRONG RS series Ø 32 ÷ 63</p>	<p>2-stage telescopic cylinders RT2 series Ø 32 ÷ 63</p>
---	--	---	---	--

CONSTRUCTION CHARACTERISTICS

Enlarged chromium-plated hollow guides provide robustness and reliability

An economical solution thanks to the components used which ensure long life (7000 – 10000 km)

Special metallic self-lubricating bearings, minimizing noise and abrasion

Customized slide units available upon request

**High resistance to peak loads.
 Scraper bearings standard supplied for J10-.../J31-... series**

All models available with safety distance 25 mm for accident prevention according to EC rules EN 349

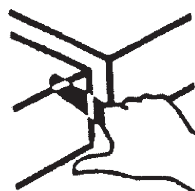

TECHNICAL CHARACTERISTICS

Working pressure:

2 ÷ 10 bar	3 ÷ 10 bar	2 ÷ 10 bar	2 ÷ 10 bar	2 ÷ 10 bar
------------	------------	------------	------------	------------

Ambient temperature:

- 20°C ÷ 80°C

SIZES

16 ÷ 100	40 ÷ 80	25 ÷ 100	32 ÷ 63	32 ÷ 63
----------	---------	----------	---------	---------

STANDARD STROKES (mm)

25 ÷ 1000	up to 800 mm max	5 ÷ 75	15 ÷ 800	120 ÷ 1200
-----------	------------------	--------	----------	------------

For min. and max. strokes refer to respective codification key.

In case there are protruding loads generating torque, the load and maximum torque values have to be reduced to 75%.

Mod. J10

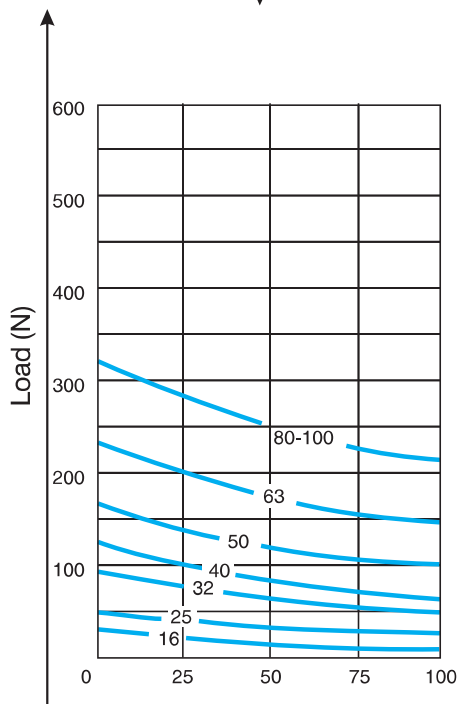
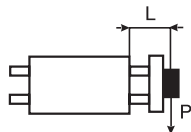

Mod. J11

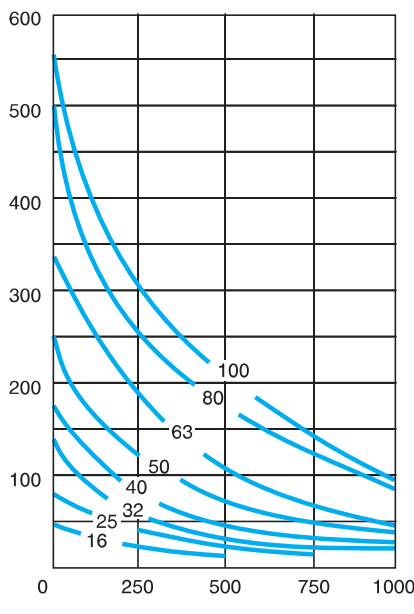
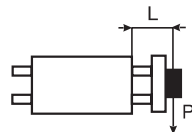

Mod. J12/J16/J17/J67

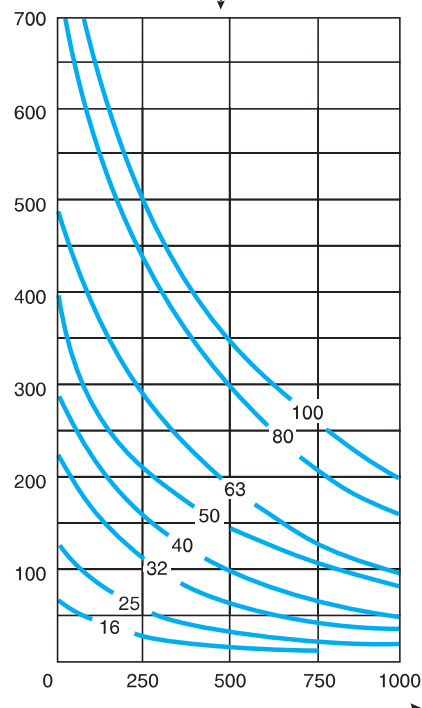
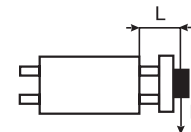

Mod. J14/J64

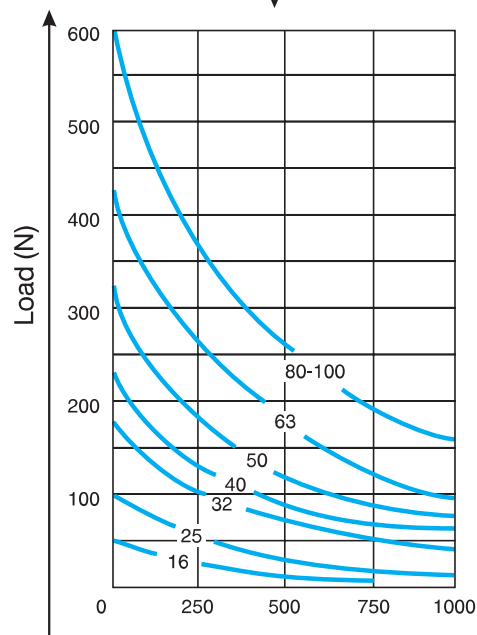
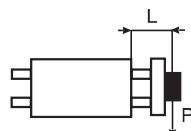

Mod. J16/J18/J19/J67

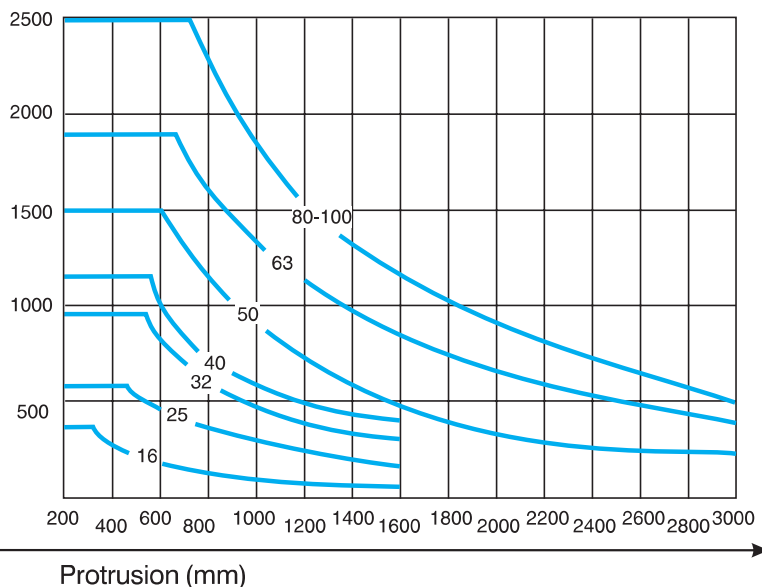
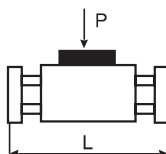

P = centre of application of the load

Mod. J10/J11/J12/J14/J16/J17/J64

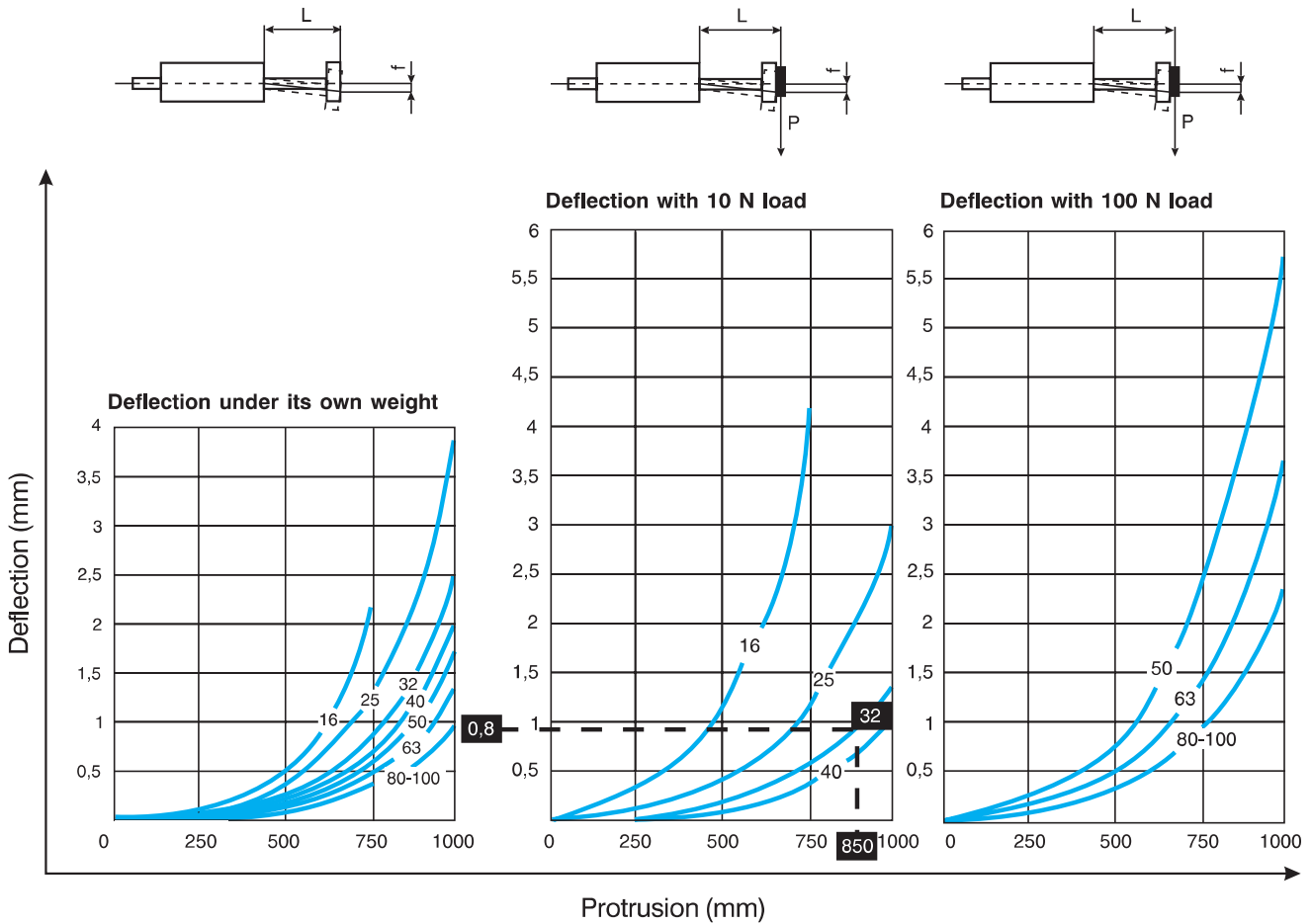

Examples of application

How to calculate deflection

The total deflection of the slide units is calculated by summing deflection under its own weight to deflection caused by the load.

For loads other than 10 or 100 N (as stated in the charts) deflection is calculated by multiplying the figure of chart (K) by the following formula:

$$f = K \cdot \frac{Q \text{ (applied load)}}{10 \text{ N or } 100 \text{ N}}$$

Example: slide unit size **32**, length **850** mm and load Q of 25 N. On chart showing deflection with 10 N load, we get coefficient **0,8** (marked with negative print), then:

$$f = 0,8 \cdot \frac{25}{10} = 2 \text{ mm}$$

The figure obtained must be added to the corresponding figure of the slide unit deflection under the unit's own weight.

Example:

slide unit Ø 63 J11

S = 500 mm (load protrusion)

Max allowed load = 100 · 0,75 = 75 N

Max allowed torque = 61,7 · 0,75 = 46,3 Nm

Max moment of resistance MR

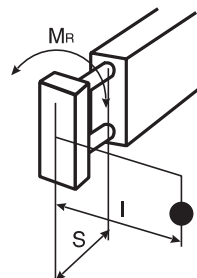

Size	MR
16	4.7 Nm
25	10.2 Nm
32	19.9 Nm
40	26.9 Nm
50	42.8 Nm
63	61.7 Nm
80	93 Nm
100	101.6 Nm

How to calculate torque

To calculate torque M1 the load P(N) must be multiplied by the arm I (mm):

$$M1 = P \cdot I$$

The figure obtained must be within MR values, as stated above: should it exceed these values, a slide unit of a bigger size must be used.



Slide units for...

Size slide unit	ISO 6431 - 6432 cylinders					Short-stroke cylinders			
	J10 M2=M3 (Nm)	J11 M2=M3 (Nm)	J12=J12B M2=M3 (Nm)	J14=J14B M2=M3 (Nm)	J16=J16B M2=M3 (Nm)	J51 M2=M3 (Nm)	J52 M2=M3 (Nm)	J53 M2=M3 (Nm)	J54 M2=M3 (Nm)
16	3,2	6,4	11	7,4	11	-	-	-	-
25	6	13,2	23,6	17,8	23,6	6	8,2	6	8,2
32	12,2	27,2	49	37,4	49	12,2	15	12,2	15
40	17,8	36,8	73,6	51	73,6	17,8	19,8	17,8	19,8
50	24,8	56	107,8	78	107,8	24,8	29,8	24,8	29,8
63	35,2	85,6	156,8	114	156,8	35,2	42,8	35,2	42,8
80	52	136	248	173,2	248	52	64,4	52	64,4
100	52	160	298	173,2	298	52	64,4	52	64,4

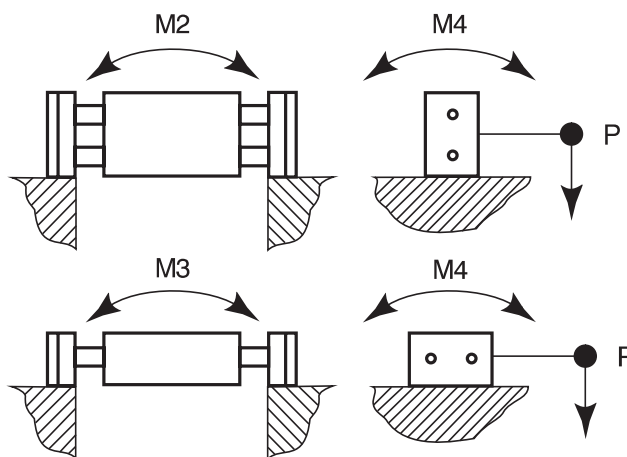

Slide units for...

Size slide unit	ISO 6431- 6432 cylinders			Short-stroke cylinders	M4 (Nm)
	J16=J16B M2/M3 (Nm)	J18 M2/M3 (Nm)	J19 M2/M3 (Nm)	J56 M2/M3 (Nm)	
16	12,8/8,8	10,4/4,4	12,8/8,8	-	9,4
25	28/19	22,2/8,6	28/19	22/7,6	20,4
32	55,6/38,8	45,2/17	55,6/38,8	42,6/15	39,8
40	80/59,4	58,5/22,6	80/59,4	57,4/19,8	53,8
50	121/75,2	92/33,4	121/75,2	90,4/29,8	85,6
63	173,6/122,6	135,2/52	173,6/122,6	130/42,4	123,4
80	270,2/196	204,2/84	270,2/196	196,6/64,4	186
100	318,6/245,6	230,8/109,2	318,6/245,6	213,2/64,4	203,2

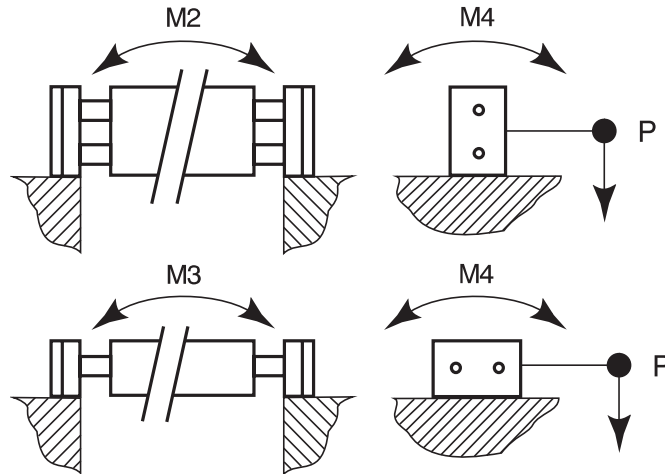

Slide units for ISO 6431 - 6432 cylinder

Size slide unit	J17=J17B M2 (Nm)							J17=J17B M3 (Nm)							M4 (Nm)
	Stroke (m/m)														
	100	200	300	400	500	750	1000	100	200	300	400	500	750	1000	
16	30,4	48,4	58	84,8	103	148,8	194,8	29	47,4	70	84,2	102,6	148,6	194,6	9,4
25	56,8	114	114	143,2	172,4	246	320	53	82,6	112	141,8	171,4	245,4	320	20,4
32	89,4	133	178	222	270	386	502	80	126,8	173,6	220	267,2	384	500	39,8
40	117	169,2	223,6	279	334,4	474,8	616	104	160,6	217,4	274	330	472	614	53,8
50	161,4	230	301,4	373,2	446	630	816	138	212,8	287,2	361,6	436	622	808	85,6
63	228	312	402	493	586	818	1102	192,8	288	383	478	573	810	1048	123,4
80	328,6	434	550,4	668	788,8	1091,2	1398	270	394	518	642	766	1076	1386	186
100	349,6	456	570	687	806	1108,6	1414	284	408	532	656	780	1090	1400	203,2

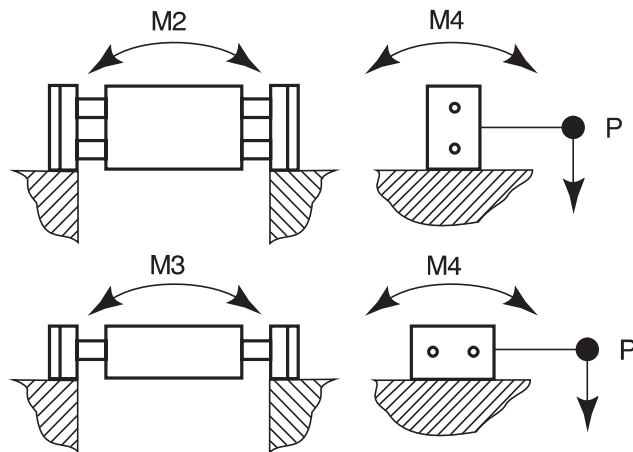

Slide units for rodless cylinder

Size slide unit	Cylinder bore (mm)	Standard carriage J30		Long carriage J31		M4 (Nm)
		M2 (Nm)	M3 (Nm)	M2 (Nm)	M3 (Nm)	
40	25	68,4	42,4	110,2	96,2	53,8
50	32	118,4	81,8	198	178,6	85,6
63	40	192,2	147,2	315	289,8	123,4
80	50	298,2	233,2	516	481,2	186

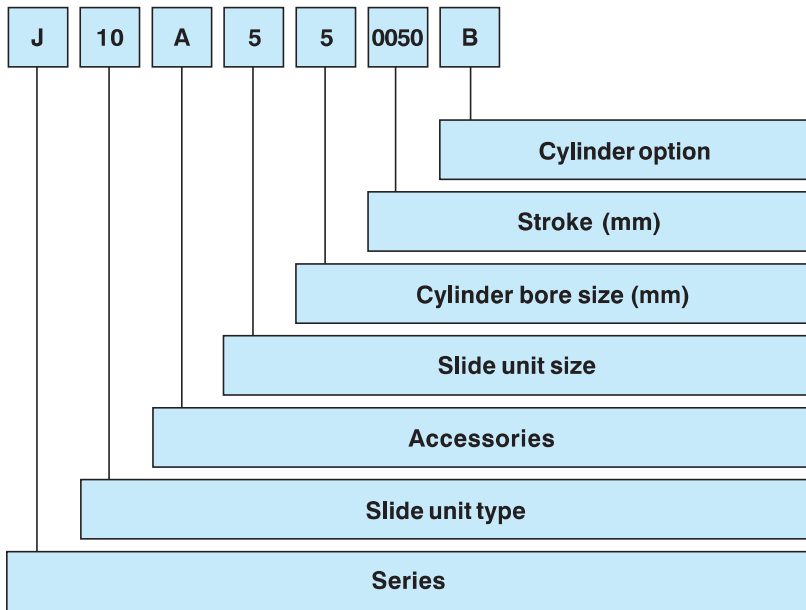

The slide units are supplied with safety distance (+ 25 mm) for accident prevention according to the European EN 349 specifications.



For obtaining the total weight it is necessary to add to the weight of the slide unit and the cylinder stroke "0" the product between the dimensions corresponding to the weight increase per mm shaft, cylinder, slide units and stroke.

Example: how to determine the mass of J11, size 32, 100 mm stroke:

	Total mass (kg)
Slide unit at zero stroke	1,3
Cylinder at zero stroke	0,504
Hollow shaft 1,17 x 100	0,117
Cylinder weight 2,35 x 100	0,235
Total	2,156

N.B.: slide units are supplied with cushioned cylinders, which in the case of J10/J11/J12/J18/J19 are magnetic. For the other series a magnetic version is foreseen by adding a DKJ Series reed switch mounting rail which is to be ordered separately (Section Accessories page 6).

SERIES

J = Slide unit series

SLIDE UNIT TYPE

- 10 = Slide unit protruding shafts, with short housing (recommended for strokes up to 50 mm)
- 11 = Slide unit protruding shafts, with medium housing
- 12 = Slide unit protruding shafts, with long housing
- 14 = Slide unit with fully protected cylinder
- 16 = Slide unit central mounting (semi-external cylinder)
- 17 = Slide unit central mounting (fully protected cylinder)
- 18 = Slide unit medium moving carriage (external cylinder)
- 19 = Slide unit long moving carriage (external cylinder)

ACCESSORIES

A = With scraper bearings

SLIDE UNIT SIZE

- 0 = 16 only for Ø 16 cylinder
- 2 = 25 only for Ø 25 cylinder
- 3 = 32 only for Ø 32 cylinder
- 4 = 40 only for Ø 40 cylinder
- 5 = 50 only for Ø 50 cylinder
- 6 = 63 only for Ø 63 cylinder
- 7 = 80 only for Ø 80 cylinder
- 8 = 100 only for Ø 100 cylinder

CYLINDER BORE SIZE

- 0 = 16
- 2 = 25
- 3 = 32
- 4 = 40
- 5 = 50
- 6 = 63
- 7 = 80
- 8 = 100

STROKE mm

Standard stroke in mm:

M series microcylinders

25 - 30 - 40 - 50 - 75 - 100 - 125 - 150 - 160 - 175
200 - 250 - 300 - 400 - 500.

K-KD series ISO cylinders

25 - 50 - 75 - 80 - 100 - 125 - 150 - 160 - 175
200 - 250 - 300 - 320 - 400 - 450 - 500.

CYLINDER OPTION

For microcylinders M series and cylinders K series:

- A = Ø 16-25 microcylinders M150 series
Ø 32-100 ISO cylinders K200 series
- B = Ø 16-25 microcylinders M250 series with locking unit
Ø 32-100 ISO cylinders K200 series with locking unit

For cylinders KD series:

- E = Ø 32-100 ISO cylinders KD200 series for the following types: J10-J11-J12-J16-J18-J19
- F = Ø 32-100 ISO cylinders KD200 series with locking unit only J1



- J10** with short housing (recommended for strokes up to 50 mm - 1 bearing)
- J11** with medium housing (2 bearings)
- J12** with long housing (2 bearings)

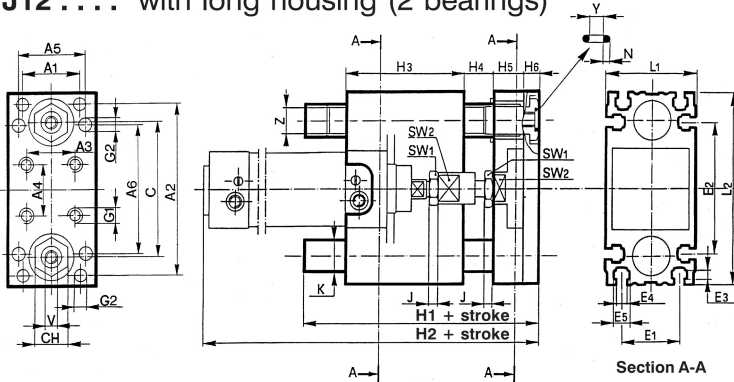
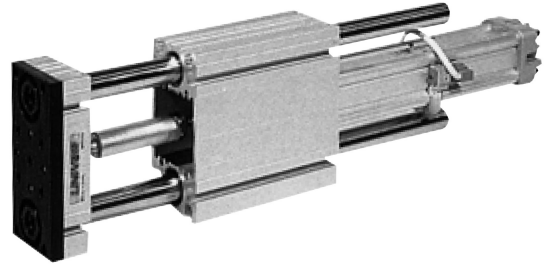

Size of slide unit	Cyl. Ø	J10....							J11....						J12....							
		+ STROKE		H3	H4	H5	H6	Mass (kg) stroke (0)	+ STROKE		H3	H4	H5	H6	Mass (kg) stroke (0)	+ STROKE		H3	H4	H5	H6	Mass (kg) stroke (0)
		H1	H2						H1	H2						H1	H2					
16	16	124	141	32	25	18	8	0,428	147	168	55	25	18	8	0,52	172	193	80	25	18	8	0,585
25	25	130	164	38	25	18	8	0,62	157	192	65	25	18	8	0,75	192	227	100	25	18	8	0,9
32	32	141	168	43	25	20	10	1,06	176	203	78	25	20	10	1,3	223	250	125	25	20	10	1,602
40	40	149	184	51	25	20	10	1,5	183	218,5	85	25	20	10	1,84	248	283,5	150	25	20	10	2,33
50	50	165	196	57	25	25	10	2,46	203	234,5	95	25	25	10	3,01	273	304,5	165	25	25	10	3,775
63*	63	171,5	213	62,5	25	25	12	3,61	219,5	260,5	110	25	25	12	4,89	294,5	329,5	185	25	25	12	6,48
80*	80	198,5	242	78,5	25	30	12	5,4	249,5	293,5	130	25	30	12	6,68	339,5	383,5	220	25	30	12	8,27
100*	100	205,5	246	85	25	30	12	6,22	269,5	321	150	25	30	12	7,52	379,5	431	260	25	30	12	9,11

J12 B with long housing, 2 bearings, with locking unit

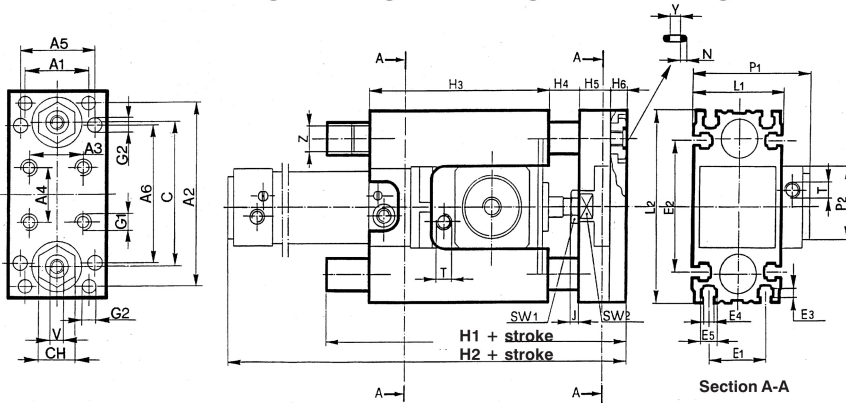

Size of slide unit	Cyl. Ø	J12...B										Mass (kg) at "0" stroke	
		+ STROKE		H3	H4	H5	H6	P1	P2	T	Slide unit	Locking unit	
		H1	H2										
25	25	186	220	94	25	18	8	77,5	40	G 1/8	0,874	0,43	
32	32	220	247	122	25	20	10	83,5	50	G 1/8	1,592	0,73	
40	40	229	265	131	25	20	10	91,5	58	G 1/8	2,18	0,9	
50	50	252	283	144	25	25	10	106,5	70	G 1/8	3,555	1,4	
63*	63	271,5	313,5	163	25	25	12	129	85	G 1/8	5,748	2,31	
80*	80	299,5	343	180	25	30	12	150	100	G 1/8	7,56	3,7	
100*	100	339,5	385	220	25	30	12	185,5	116	G 1/8	8,385	7,3	



* For dimensions not indicated and note regarding sizes 63 - 80 - 100 refer to page 45.

J14 , 2 bearings

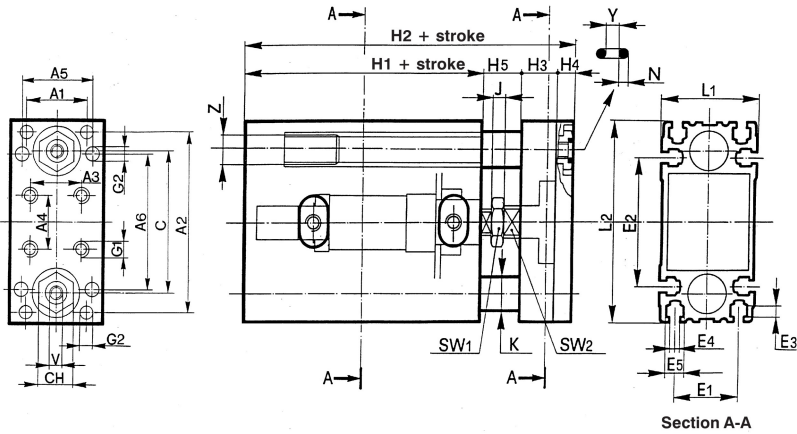

Size of slide unit	Cyl. Ø	J14....					Mass (kg) at "0" stroke
		+ STROKE		H3	H4	H5	
		H1	H2				
16	16	100	151	18	8	25	0,62
25	25	120	171	18	8	25	0,947
32	32	130	185	20	10	25	1,58
40	40	140	195	20	10	25	2,17
50	50	150	210	25	10	25	3,48
63*	63	165	227	25	12	25	5,08
80*	80	180	247	30	12	25	6,87
100*	100	195	262	30	12	25	7,74

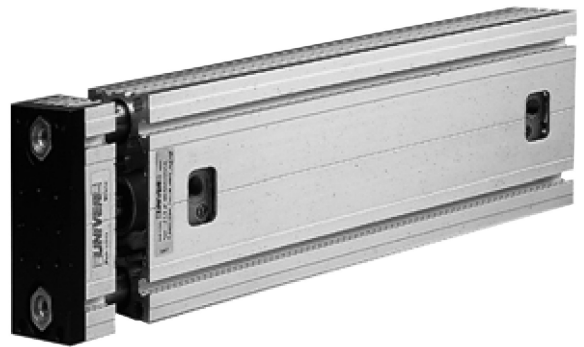

J14 B, 2 bearings with locking unit

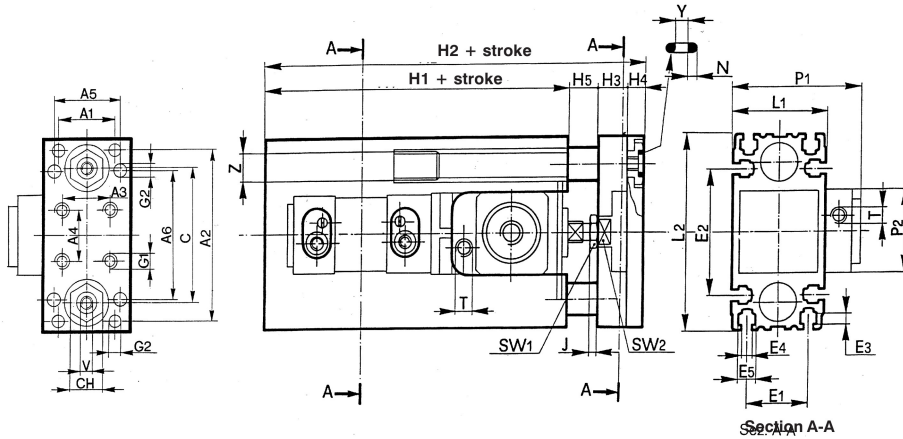

Size of slide unit	Cyl. Ø	J14...B							Mass (kg) at "0" stroke		
		+ stroke		H3	H4	H5	P1	P2	T	Slide unit	Locking units
		H1	H2								
25	25	179	230	18	8	25	77,5	40	G 1/8	1,183	0,43
32	32	209	264	20	10	25	83,5	50	G 1/8	2,055	0,73
40	40	222	277	20	10	25	91,5	58	G 1/8	2,805	0,9
50	50	236	296	25	10	25	106,5	70	G 1/8	3,526	1,4
63*	63	250	312	25	12	25	129	85	G 1/8	6,71	2,31
80*	80	285	352	30	12	25	150	100	G 1/8	8,5	3,7
100*	100	335	402	30	12	25	185,5	116	G 1/8	9,32	7,3

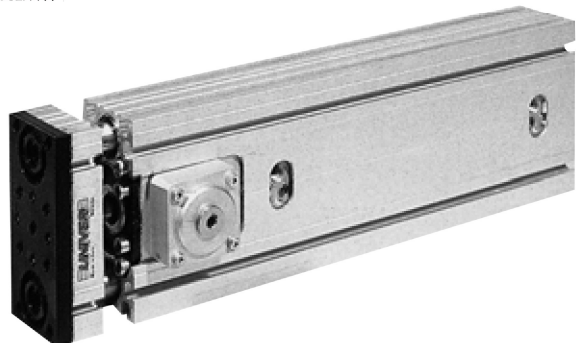

* For dimensions not indicated and note regarding sizes 63 - 80 - 100 refer to page 45.



J16 , 2 bearings

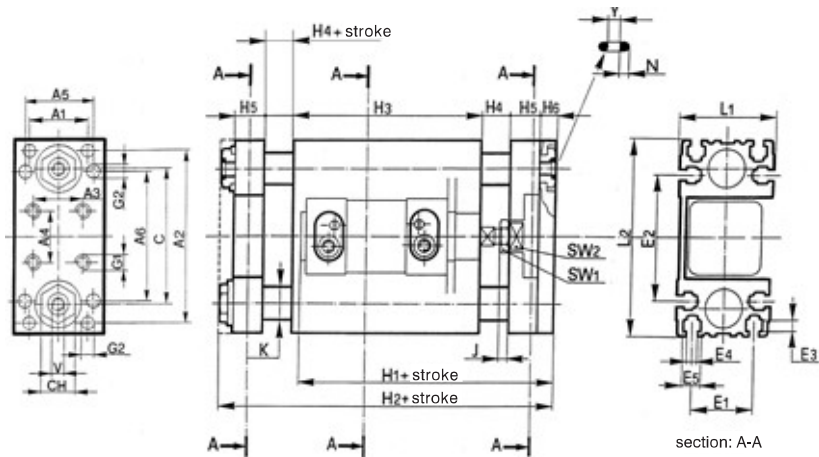

Size of slide unit	Cyl. Ø	J16....						Mass (kg) at "0" stroke
		+ STROKE		H3	H4	H5	H6	
		H1	H2					
16	16	137	182	80	25	18	8	0,685
25	25	156	202	100	25	18	8	1,022
32	32	168	235	125	25	20	10	1,985
40	40	184	260	150	25	20	10	2,452
50	50	195	285	165	25	25	10	3,82
63*	63	213	309	185	25	25	12	6,77
80*	80	244	354	220	25	30	12	8,56
100*	100	256	394	260	25	30	12	9,39

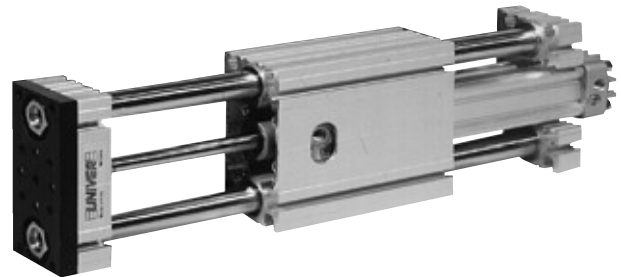

J16 B, 2 bearings with locking unit

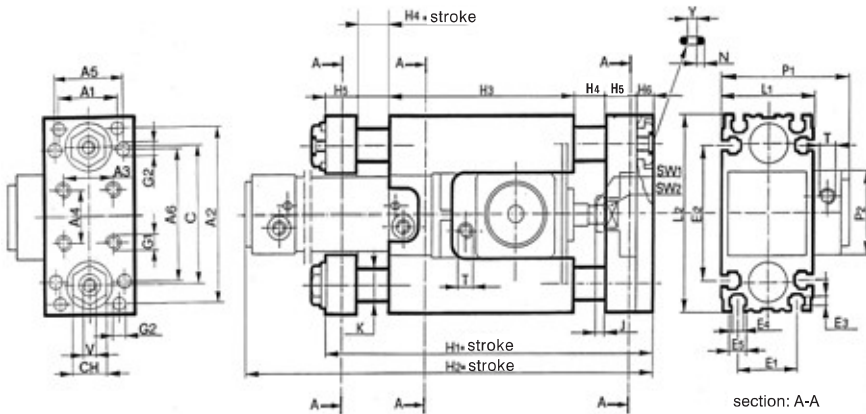

Size of slide unit	Cyl. Ø	J16....B									Mass (kg) at "0" stroke	
		+ STROKE		H3	H4	H5	H6	P1	P2	T	Slide unit	Locking unit
		H1	H2									
25	25	188	220	94	25	18	8	77,5	40	G 1/8	0,94	0,43
32	32	222	247	122	25	20	10	83,5	50	G 1/8	1,965	0,73
40	40	231	265	131	25	20	10	91,5	58	G 1/8	2,3	0,9
50	50	254	283	144	25	25	10	106,5	70	G 1/8	3,59	1,4
63	63	275	313,5	163	25	25	12	129	85	G 1/8	6,4	2,31
80	80	302	343	180	25	30	12	150	100	G 1/8	8,19	3,7
100	100	342	385	220	25	30	12	185,5	116	G 1/8	9,02	7,3

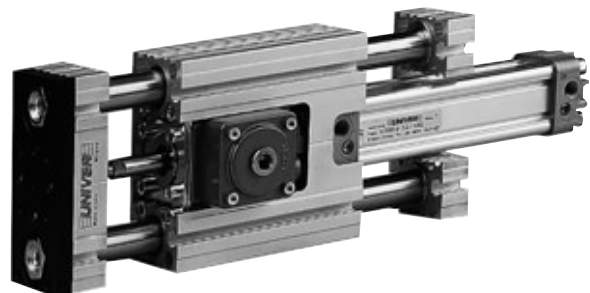

*For dimensions not indicated and note regarding sizes 63 - 80 - 100 refer to page 45.

J17 , 2 bearings

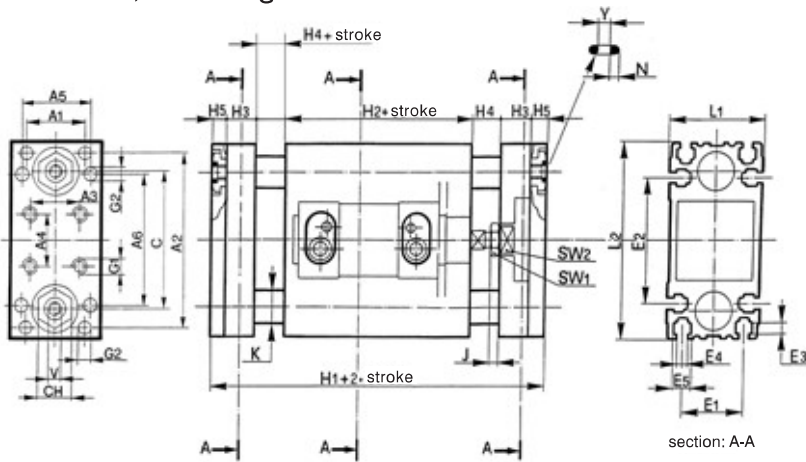

Size of slide unit	Cyl. Ø	J17....						Mass (kg) at "0" stroke	
		+ 2 • STROKE		+ STROKE		H3	H4		H5
		H1	H2	H3	H4				
16	16	202	100	18	25	8	0,715		
25	25	222	120	18	25	8	1,243		
32	32	240	130	20	25	10	1,925		
40	40	250	140	20	25	10	2,234		
50	50	270	150	25	25	10	3,39		
63*	63	289	165	25	25	12	6,19		
80*	80	314	180	30	25	12	7,985		
100*	100	329	195	30	25	12	8,935		



J17 B, 2 bearings with locking unit

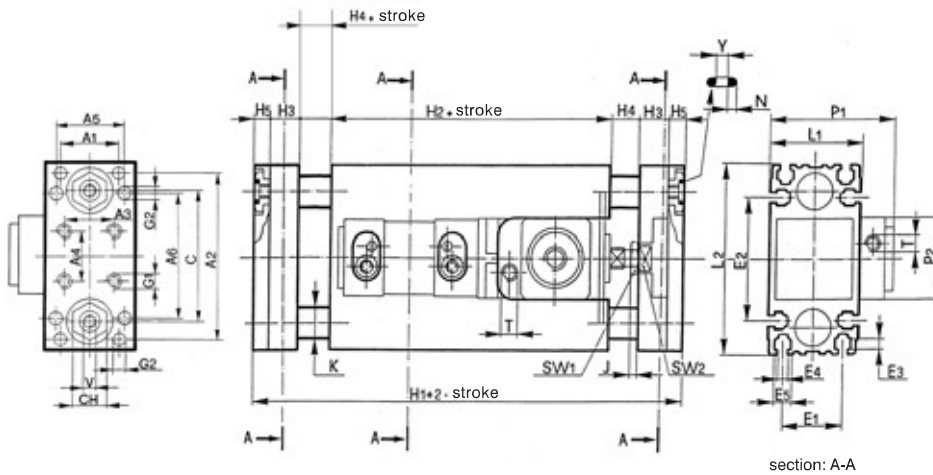

Size of slide unit	Cyl. Ø	J17...B										Mass (kg) at "0" stroke	
		+ 2 • STROKE		+ STROKE		H3	H4	H5	P1	P2	T	Slide unit	Locking unit
		H1	H2	H3	H4								
25	25	281	179	18	25	8	77,5	40	G 1/8	1,386	0,43		
32	32	319	209	20	25	10	83,5	50	G 1/8	2,59	0,73		
40	40	332	222	20	25	10	91,5	58	G 1/8	3,145	0,9		
50	50	356	236	25	25	10	106,5	70	G 1/8	4,55	1,4		
63*	63	374	250	25	25	12	129	85	G 1/8	5,99	2,31		
80*	80	419	285	30	25	12	150	100	G 1/8	7,79	3,7		
100*	100	469	335	30	25	12	185,5	116	G 1/8	8,64	7,3		



*For dimensions not indicated and note regarding sizes 63 - 80 - 100 refer to page 45.

J18 , slide unit with medium carriage
(2 bearings)

J19 , slide unit with long carriage
(2 bearings)

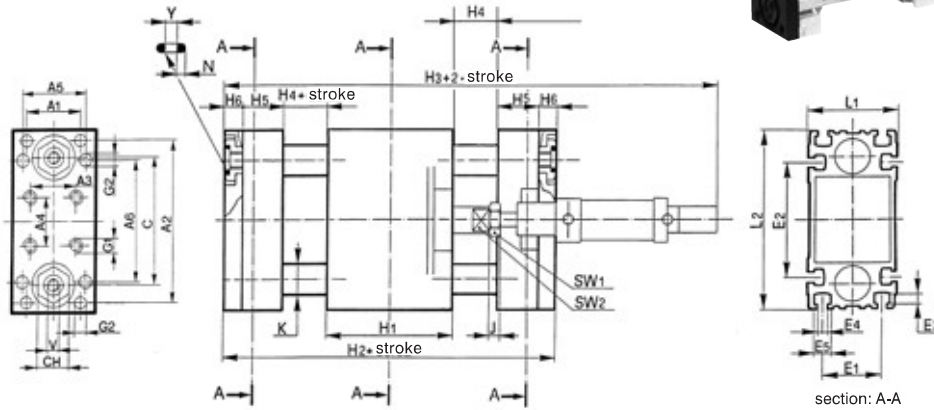
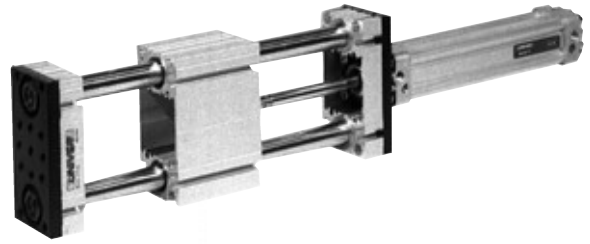

Size of slide unit	Cyl. Ø	J18....							J19....						
		H1	+ STROKE H2	+ 2 • STROKE H3	H4	H5	H6	Mass (kg) at "0" stroke	H1	+ STROKE H2	+ 2 • STROKE H3	H4	H5	H6	Mass (kg) at "0" stroke
16	16	55	157	230	25	18	8	0,636	80	182	255	25	18	8	0,7
25	25	65	167	258	25	18	8	0,904	100	202	293	25	18	8	1,044
32	32	78	188	285	25	20	10	1,685	125	235	332	25	20	10	1,968
40	40	85	195	304	25	20	10	2,15	150	260	369	25	20	10	2,645
50	50	95	215	325	25	25	10	3,44	165	285	395	25	25	10	4,205
63*	63	110	234	359	25	25	12	5,33	185	309	434	25	25	12	6,82
80*	80	130	264	397	25	30	12	7,225	220	354	487	25	30	12	8,61
100*	100	150	284	428	25	30	12	8,05	260	394	538	25	30	12	9,435

Common dimensions of slide units with ISO 6431-6432 cylinders

Size of slide unit	Cyl. Ø	A1	A2	A3	A4	A5	A6	C	CH	E1	E2	E3	E4	E5	G1	G2*	J	K	L1	L2	N
16	16	19,9	70,6	24	30	-	-	51	13	20	46	3,5	4,4	7,4	M4	Ø 4H8	4	12	32	77	1,78
25	25	32	85	27	27	36	62	69	14	32	62	5	5,4	8,4	M5	Ø 6H8	6	16	47	96	1,78
32	32	38	108	32,5	32,5	46	82	85	22	38	82	5	6,4	10,4	M6	Ø 6H8	6	20	58	120	2,62
40	40	42	118	38	38	54	90	95	22	42	90	5	6,4	10,4	M6	Ø 8H8	7	22	66	130	2,62
50	50	48,1	140	46,5	46,5	69	110	115	27	48	110	6,5	8,4	13,4	M8	Ø 8H8	8	25	84	155	2,62
63	63	56	157,5	56,5	56,5	79,5	120	130	30	56	120	7,5	10,5	17,5	M8	Ø 8H8	8	28	98	176	2,62
80	80	65	178	72	72	95	142	150	32	65	142	8,5	10,5	18	M10	Ø 8H8	9	32	117	200	2,62
100	100	72	194	89	89	113	156	164	32	72	156	8,5	10,5	18	M10	Ø 8H8	9	32	133	214	2,62

* For use with locating pin tolerance m 6.

Size of slide unit	Cyl. Ø	SW1	SW2	V	Y	Z	Mass increase (g) per mm stroke			
							Mass (kg) at "0" stroke	Cylinder	Cylinder	Shaft
16	16	10	9	M5	5,28	M10	0,073	0,55	0,98	2,6
25	25	17	12	M5	5,28	M12	0,208	1,15	1,92	4
32	32	17	17	G 1/8	10,78	M16x1,5	0,504	2,35	2,51	6
40	40	19	17	G 1/8	10,78	M18x1,5	0,764	3,24	2,81	7,6
50	50	24	22	G 1/8	10,78	M20x1,5	1,207	4,75	3,71	11
63	63	24	22	G 1/8	10,78	M22x1,5	1,74	5,78	4,7	13,6
80	80	30	30	G 1/8	10,78	M27x2	2,74	8,64	5,52	18
100	100	30	30	G 1/8	10,78	M27x2	3,78	10,4	5,52	20

N.B.: on the 4 sides the plates for sizes 63 - 80 - 100 have chamfers as indicated in the following table:

Size	α
63	20°
80	35°
100	40°



Aluminium foot brackets

SIZE	A	B	C	D	E	F	G	H	L	Part number
16	52	30	10	26	4	9	20	∅ 4,5	43	JF-13016
25	70	30	10	26	4	9	32	∅ 5,5	57	JF-13025
32	85	35	10	30	5	10	38	∅ 6,5	72	JF-13032
40	92	35	10	30	5	10	42	∅ 6,5	79	JF-13040
50	11	40	15	35	5	12,5	48	∅ 8,5	102	JF-13050
63	13	45	15	40	5	15	56	∅ 10,5	112	JF-13063
80	16	45	15	40	5	15	65	∅ 10,5	135	JF-13080
100	17	45	15	40	5	15	72	∅ 10,5	151	JF-13100

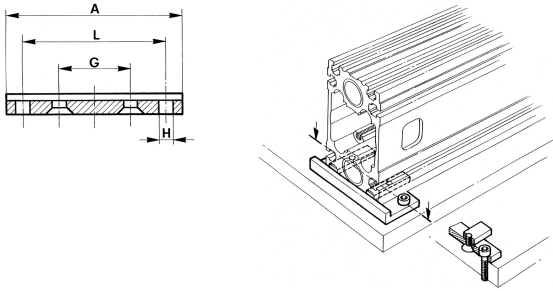

Package consists of 2 pcs. including mounting accessories.

Fixing plates in steel

SIZE	A	B	C	D	E	F	Part number
16	3	7	7,5	15	30	M4	JF-42016
25	4	8	10	15	35	M5	JF-42025
32 - 40	4	10	10	20	40	M6	JF-42040
50	6	13	10	30	50	M8	JF-42050
63	6	16	12,5	35	60	M10	JF-42063
80 - 100	8	16	15	40	70	M10	JF-42100

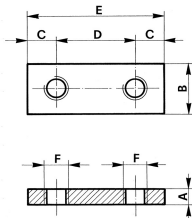

Package consists of 2 pcs. including mounting accessories.

**Shaft support for slide units
J10/J11/J12 Series**

SIZE	Part number
16	JF-601016
25	JF-601025
32	JF-601032
40	JF-601040
50	JF-601050
63	JF-601063
80	JF-601080
100	JF-601100

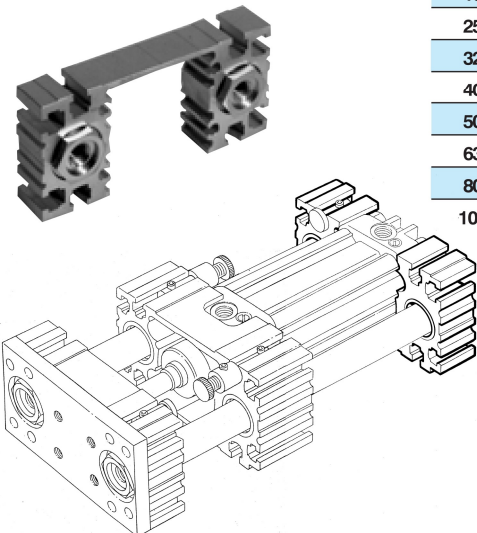

SIZE	A	B	C	D	E	F	G	H	Part number
16	50	30	10	26	3	9	31	∅ 4,5	JF-14016
25	55	30	10	26	3	9	34	∅ 5,5	JF-14025
32	60	35	10	30	4	10	38	∅ 6,5	JF-14032
40	65	35	10	30	4	10	40	∅ 6,5	JF-14040
50	70	40	15	35	4	12,5	45	∅ 8,5	JF-14050
63	85	45	15	40	4	15	56	∅ 10,5	JF-14063
80 - 100	90	45	15	40	4	15	58	∅ 10,5	JF-14100

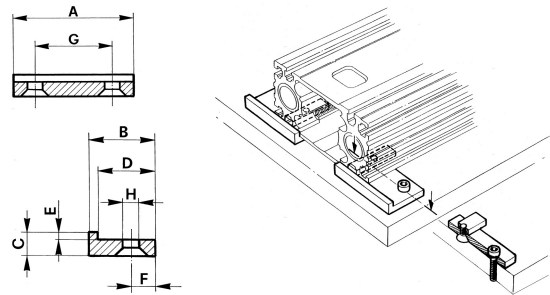

Package consists of 4 pcs. including mounting accessories.

SIZE	A	B	C	D	Part number
16	3	7	16	M4	JF-43016
25	4	8	16	M5	JF-43025
32 - 40	4	10	18	M6	JF-43040
50	6	13	18	M8	JF-43050
63	6	16	22	M10	JF-43063
80 - 100	8	16	25	M10	JF-43100

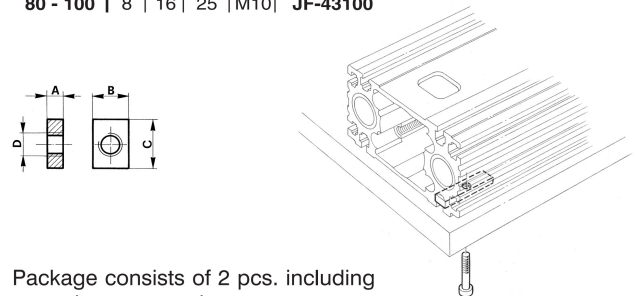

Package consists of 2 pcs. including mounting accessories.

Scraper bearings

SIZE	∅ A	Part number
16	12	JF-19016
25	16	JF-19025
32	20	JF-19032
40	22	JF-19040
50	25	JF-19050
63	28	JF-19063
80 - 100	32	JF-19100

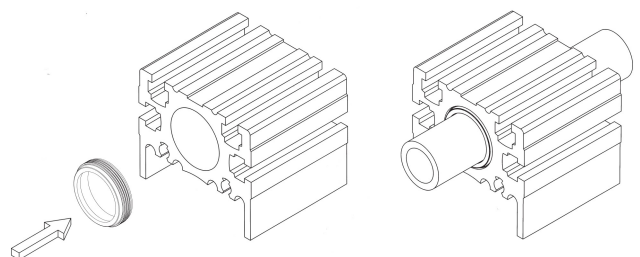
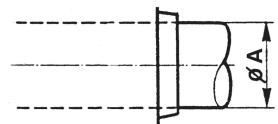

Package comprises 4 pcs.