

BE/BE12

ISO 5599/1 Valves

- Compliance with ISO 5599/1 international standards
- Full range: 1 - 2 - 3 - 4 size
- Two different internal commutation system: mixed and spool, appreciated for decades thanks to their maximum reliability
- High capacity
- Short internal stroke
- No lubrication
- Electric connection M12 for 1 - 2 - 3 size
- Modular base
- Possibility of mounting different sizes on the same sub-base

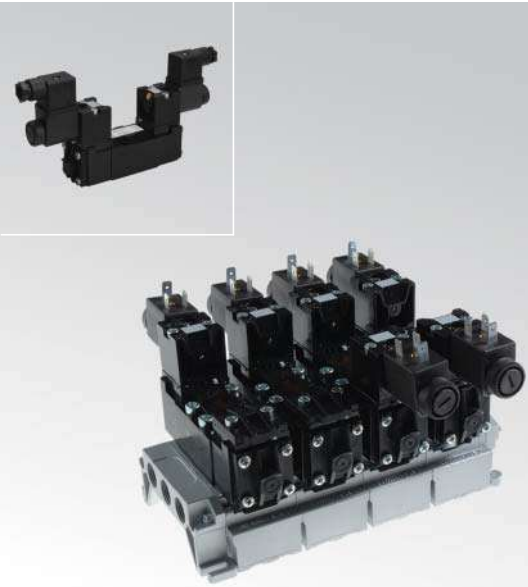

TECHNICAL CHARACTERISTICS

Ambient temperature	-10 ÷ +50 °C
Fluid temperature	max +50 °C
Fluid	mixed system: not dehumidified filtered air 50 µm spool system: filtered air 50 µm, dehumidified or not
Commutation system	mixed system, spool system
Ways/Positions	5/2, 5/3
Pressure	10 bar max
Control	indirect electro - pneumatic, pneumatic
Return	mixed system: pneumomechanical spring spool system: mechanical spring

Connections	ISO 5599/1 interface			
	size 1	size 2	size 3	size 4
Nominal Ø (mm)	8	10	15	19
Nominal flow rate (NI/min)	1480	2300	4200	6600

CONSTRUCTIVE CHARACTERISTICS

Valve body	acetalic resin
Cover	zamak - aluminium
Seals	mixed system: nitrile rubber and polyurethane spool system: nitrile rubber
Sub-base	zamak - aluminium
Actuators	technopolymer
Spool	aluminium

ELECTRIC CHARACTERISTICS

Electropilot	AA CNOMO (U1) series
Coil	U3 DC series
Power consumption	2,5 W (DC) - 5 VA (AC)
Voltage	12 V DC - 24 V DC - 24 V AC - 110 V AC - 230 V AC
Connector	AM 5111
Manual override	with two position screw (standard) with button with tool (upon request)

Flow rate characteristics

>> ISO 1

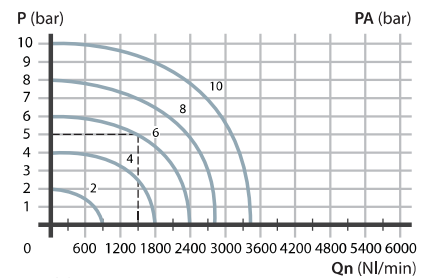

>> ISO 2

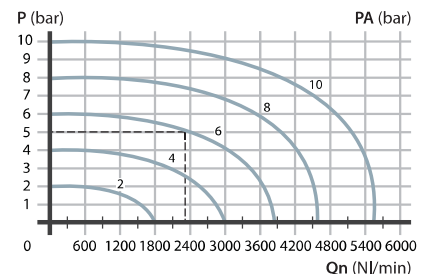

>> ISO 3

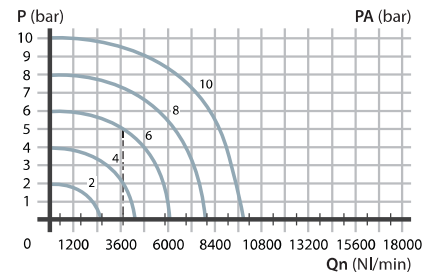

>> ISO 4

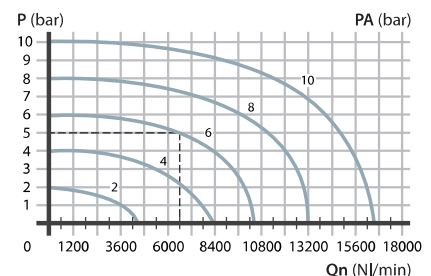

P = Working pressure
PA = Supply pressure
Qn = Nominal flow rate

ISO 5599/1 Standard

The ISO standard for pneumatic valves is accepted by industry and by the majority of major pneumatic valve manufactures throughout the world. The choice of valves according to ISO standard means to be at the technical forefront and to guarantee the user the interchangeability of both the valve body and the electromagnetic part

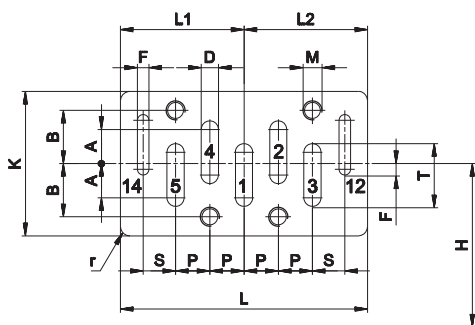

	A	B	D	F	H	K	L	L1	L2	M	P	r	S	T
ISO 1	9	14	4,5	3	43	38	65	32,5	32,5	M5	9	2,5	8,5	16,5
ISO 2	10	19	7	3	56	50	81	40,5	40,5	M6	12	3	10	22
ISO 3	11,5	24	10	4	71	64	106	53	53	M8	16	4	13	29
ISO 4	14,5	29	13	4	82	74	142	77,5	64,5	M8	20	4	15,5	36,5

Standard manual overrides

Functioning	Suitable for valve	Symbol/Part no.
1 = with 2 position screw	BE	⊖
2 = with button with tool	BE	→
3 = with embedded button, 1 position	BE12	→

Special versions available (upon request): with 1 - 2 position button, with 1 position frontal button, with 1 position button

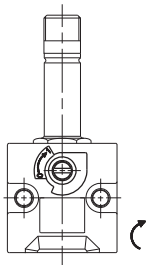

1

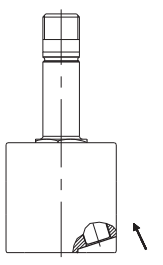

2

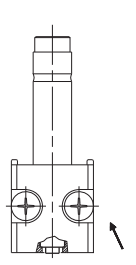

3

Single/double **pneumatic impulse**

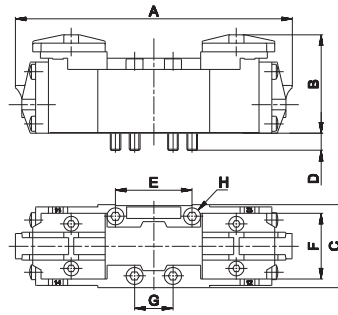

	ISO 1	ISO 2	ISO 3	ISO 4
A	128	145	191	222
B	47	47	63	63
C	39	52	64	74
D	5	5	10	10
E	36	48	64	80
F	28	38	48	58
G	18	24	32	40
H	M5x38	M6x35	M8x50	M8x50

	Symbol	Control	Return	Pressure bar	Times (ms)		Size	Weight Kg	Part no.
					En.	De-en.			
MIXED SYSTEM									
5/2		pneumatic amplified	pneumomechanical spring	2÷10	9	18	1	0,30	BE-3100
				2,3÷10	11	14	2	0,40	BE-4100
				2,5÷10	19	49	3	0,65	BE-5100
				3÷10	23	46	4	0,87	BE-6100
5/2		pneumatic amplified	pneumatic amplified	1÷10	5	5	1	0,30	BE-3150
				1÷10	6	6	2	0,40	BE-4150
				1÷10	10	10	3	0,65	BE-5150
				1,3÷10	12	12	4	0,87	BE-6150
5/2		pneumatic amplified	pneumatic not amplified	2÷10	5	16	1	0,30	BE-3170
				2÷10	6	13	2	0,40	BE-4170
				2,2÷10	10	35	3	0,65	BE-5170
				2,2÷10	12	32	4	0,87	BE-6170
SPOOL SYSTEM									
5/2		pneumatic amplified	pneumomechanical spring	1,8÷10	11	22	1	0,30	BE-3800
				2÷10	13	19	2	0,40	BE-4800
				2,2÷10	21	52	3	0,65	BE-5800
				2,8÷10	24	29	4	0,87	BE-6800
5/2		pneumatic amplified	pneumatic amplified	0,8÷10	6	6	1	0,30	BE-3850
				1÷10	7	7	2	0,40	BE-4850
				1÷10	12	12	3	0,65	BE-5850
				1÷10	14	14	4	0,87	BE-6850
5/2		pneumatic amplified	pneumatic not amplified	1,5÷10	6	15	1	0,30	BE-3870
				1,8÷10	7	14	2	0,40	BE-4870
				2÷10	12	38	3	0,65	BE-5870
				2÷10	14	31	4	0,87	BE-6870

Single **electric impulse**

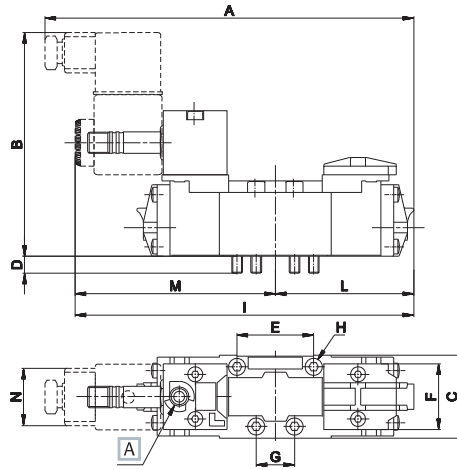

	ISO 1	ISO 2	ISO 3	ISO 4
A	169,5	195,5	219	253
B	105	105	118	118
C	39	52	64	74
D	5	5	10	10
E	36	48	64	80
F	28	38	48	58
G	18	24	32	40
H	M5x38	M6x35	M8x50	M8x50
I	159,5	176	208,5	235
L	64	72,5	95,5	111
M	95,5	103,5	113	124
N	30	30	30	30

A Manual override

	Symbol	Control	Return	Pressure bar	Times (ms)		Size	Weight Kg	Part no.
					En.	De-en.			
MIXED SYSTEM									
5/2		electric amplified	pneumomechanical spring	2÷10	20	32	1	0,45	BE-3000
				2,3÷10	24	25	2	0,55	BE-4000
				2,5÷10	32	71	3	0,90	BE-5000
				3÷10	38	62	4	1,12	BE-6000
5/2		electric amplified	pneumatic amplified	1÷10	16	6	1	0,45	BE-3060
				1÷10	17	7	2	0,80	BE-4060
				1÷10	23	15	3	1,30	BE-5060
				1,3÷10	25	16	4	1,37	BE-6060
SPOOL SYSTEM									
5/2		electric amplified	pneumomechanical spring	2÷10	21	35	1	0,45	BE-3700
				2,2÷10	24	30	2	0,55	BE-4700
				2,3÷10	33	74	3	0,90	BE-5700
				2,8÷10	39	68	4	1,12	BE-6700
5/2		electric amplified	pneumatic amplified	1÷10	17	8	1	0,45	BE-3760
				1÷10	18	9	2	0,80	BE-4760
				1÷10	26	17	3	1,30	BE-5760
				1,3÷10	27	18	4	1,37	BE-6760

For manual version with button, add "U" to the end of the part number
Electrovalves are supplied without coil, connector and locking ring

Double electric impulse

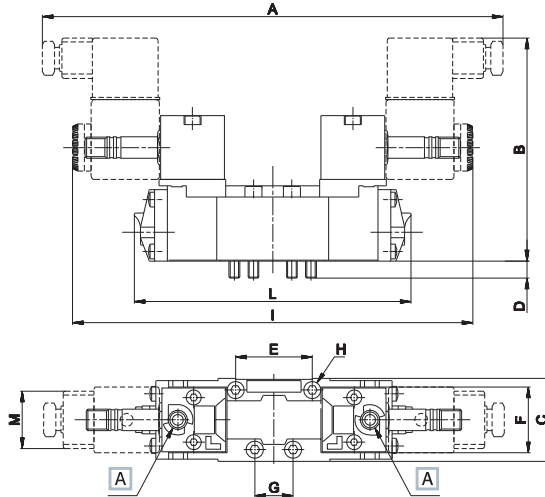

	ISO 1	ISO 2	ISO 3	ISO 4
A	211	226	247	268
B	105	105	118	118
C	39	52	64	74
D	5	5	10	10
E	36	48	64	80
F	28	38	48	58
G	18	24	32	40
H	M5x38	M6x35	M8x50	M8x50
I	191	207	226	248
L	128	145	191	222
M	30	30	30	30

A Manual override

	Symbol	Control	Return	Pressure bar	Times (ms)		Size	Weight Kg	Part no.
					En.	De-en.			
MIXED SYSTEM									
5/2		electric amplified	electric amplified	1÷10	16	16	1	0,55	BE-3020
				1÷10	17	17	2	0,80	BE-4020
				1÷10	23	23	3	1,20	BE-5020
				1,3÷10	25	25	4	1,37	BE-6020
5/2		electric amplified	electric non amplified	2÷10	16	34	1	0,55	BE-3030
				2÷10	17	29	2	0,80	BE-4030
				2,2÷10	23	54	3	1,20	BE-5030
				2,2÷10	25	45	4	1,37	BE-6030
5/3 o.c.		electric amplified	electric amplified	3÷10	50	26	1	0,55	BE-3200
				3÷10	54	24	2	0,80	BE-4200
				3÷10	108	36	3	1,20	BE-5200
				3÷10	115	115	4	1,37	BE-6200
5/3 p.c.		electric amplified	electric amplified	2÷10	50	26	1	0,50	BE-3205
				2,3÷10	54	24	2	0,80	BE-4205
				2,5÷10	108	36	3	1,20	BE-5205
				3÷10	115	115	4	1,37	BE-6205
SPOOL SYSTEM									
5/2		electric amplified	electric amplified	1÷10	17	17	1	0,55	BE-3720
				1÷10	18	18	2	0,80	BE-4720
				1÷10	26	26	3	1,20	BE-5720
				1÷10	27	27	4	1,37	BE-6720
5/2		electric amplified	electric non amplified	1,8÷10	17	28	1	0,55	BE-3730
				1,8÷10	18	25	2	0,80	BE-4730
				2÷10	26	46	3	1,20	BE-5730
				2÷10	27	42	4	1,37	BE-6730
5/3 o.c.		electric amplified	electric amplified	2,3÷10	17	25	1	0,55	BE-3900
				2,5÷10	18	27	2	0,80	BE-4900
				2,5÷10	26	50	3	1,20	BE-5900
				2,5÷10	30	47	4	1,37	BE-6900
5/3 c.c.		electric amplified	electric amplified	2,3÷10	17	25	1	0,55	BE-3940
				2,5÷10	18	27	2	0,80	BE-4940
				2,5÷10	26	50	3	1,20	BE-5940
				2,5÷10	30	47	4	1,37	BE-6940

o.c. = open centres c.c. = closed centres p.c. = pressurized centres

For manual version with button, add "U" to the end of the part number

Electrovalves are supplied without coil, connector and locking ring

The use of pneumatic component in the automotive field, coupled with electric components, led to the development of a traditional ISO valve with electric connector M12 placed in central position, for both valves with single as well as double electric control.

Single/double electric impulse



	Symbol	Control	Return	Pressure bar	Times (ms)		Size	Weight Kg	Part no.
					En.	De-en.			
SINGLE IMPULSE - MIXED SYSTEM									
5/2		electric amplified	pneumomechanical spring	2÷9	18	29	1	0,45	BE12-3000
				2,3÷9	23	24	2	0,55	BE12-4000
				2,5÷9	35	78	3	0,90	BE12-5000
SINGLE IMPULSE - SPOOL SYSTEM									
5/2		electric amplified	pneumomechanical spring	2÷9	19	32	1	0,45	BE12-3700
				2,2÷9	23	28	2	0,55	BE12-4700
				2,3÷9	36	82	3	0,90	BE12-5700
DOUBLE IMPULSE - MIXED SYSTEM									
5/2		electric amplified	electric amplified	1÷9	14	14	1	0,55	BE12-3020
				1÷9	16	16	2	0,80	BE12-4020
				1÷9	25	25	3	1,20	BE12-5020
5/3 c.p.		electric amplified	electric amplified	2÷9	45	23	1	0,50	BE12-3205
				2,3÷9	51	23	2	0,80	BE12-4205
				2,5÷9	119	40	3	1,20	BE12-5205
DOUBLE IMPULSE - SPOOL SYSTEM									
5/2		electric amplified	electric amplified	1÷9	15	15	1	0,55	BE12-3720
				1÷9	17	17	2	0,80	BE12-4720
				1÷9	29	29	3	1,20	BE12-5720
5/3 o.c.		electric amplified	electric amplified	2,3÷9	15	22	1	0,55	BE12-3900
				2,5÷9	17	26	2	0,80	BE12-4900
				2,5÷9	29	55	3	1,20	BE12-5900
5/3 c.c.		electric amplified	electric amplified	2,3÷9	15	22	1	0,55	BE12-3940
				2,5÷9	17	26	2	0,80	BE12-4940
				2,5÷9	29	55	3	1,20	BE12-5940

c.a. = centri aperti c.c. = centri chiusi c.p. = centri in pressione

Valves are supplied with 24 V DC coil

Single electric impulse

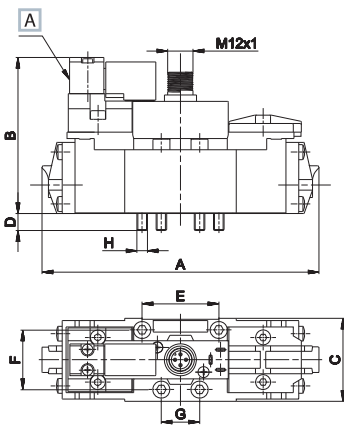

Double electric impulse

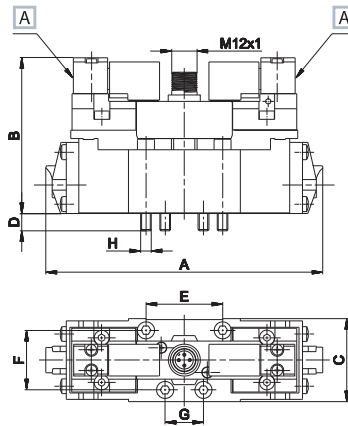

	ISO 1	ISO 2	ISO 3
A	128	145	191
B	73	73	90
C	39	52	64
D	5	5	10
E	36	48	64
F	28	38	48
G	18	24	32
H	M5x38	M6x35	M8x50

Manual override

ELECTRIC FEATURES

- Central electric connector M12x1
- IP 65 protection degree
- 24 V DC voltage
- 2,5 W nominal power
- DD-052** series coil (without faston)
- ED 100%
- LED indicator

Available upon request other voltages
max 48 V DC

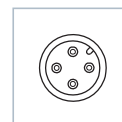
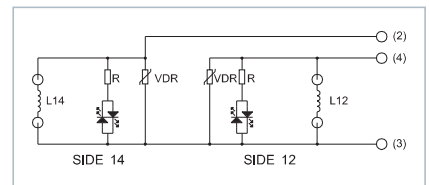

ISO 1 - Single sub-base, side connections

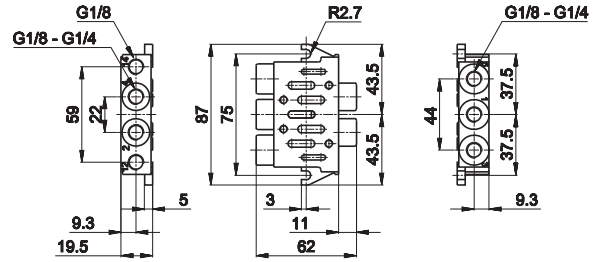

Notes	Connection	Material	Weight Kg	Part no.
in line connections	G1/8	zamak	0,250	BF-1060
in line connections	G1/4	zamak	0,230	BF-1061

1 = Supply port 3 - 5 = Exhaust
2 - 4 = Use 12 - 14 = Pilots

ISO 2 - Single sub-base, side connections

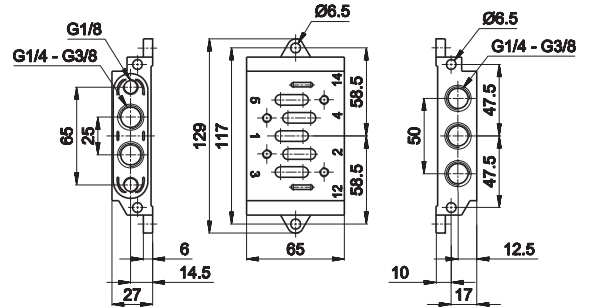

Notes	Connection	Material	Weight Kg	Part no.
in line connections	G1/4	zamak	0,640	BF-1150
in line connections	G3/8	zamak	0,650	BF-1151

1 = Supply port 3 - 5 = Exhaust
2 - 4 = Use 12 - 14 = Pilots

ISO 3 - Single sub-base, side connections

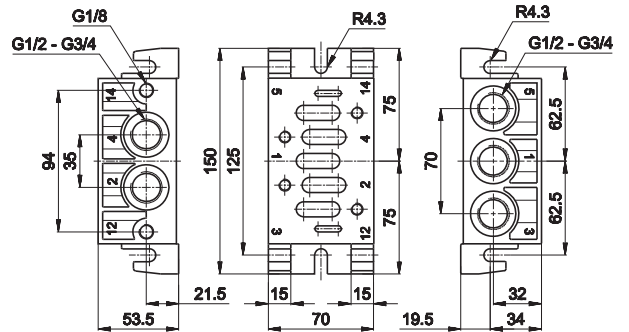

Notes	Connection	Material	Weight Kg	Part no.
in line connections	G1/2	aluminium	0,740	BF-3060
in line connections	G3/4	aluminium	0,740	BF-3061

1 = Supply port 3 - 5 = Exhaust
2 - 4 = Use 12 - 14 = Pilots

ISO 4 - Single sub-base, side connections

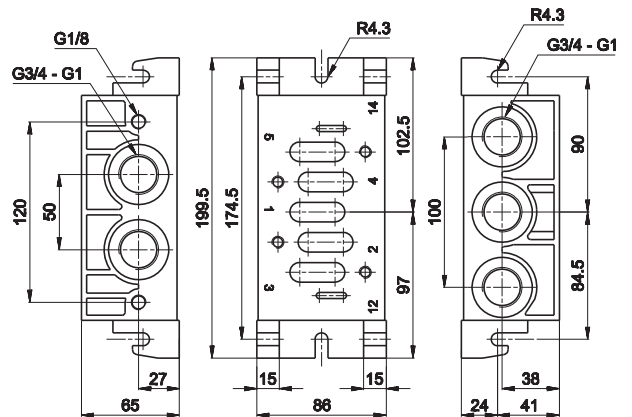

Notes	Connection	Material	Weight Kg	Part no.
in line connections	G3/4	aluminium	1,280	BF-4060
dorsal and side connections	G1	aluminium	1,280	BF-4061

1 = Supply port 3 - 5 = Exhaust
2 - 4 = Use 12 - 14 = Pilots

ISO 1 - Single modular or Manifold sub-base, dorsal connections, separate exhausts



Notes	Connection	Material	Weight Kg	Part no.
dorsal connections	G1/8	zamak	0,350	BF-1062
dorsal connections	G1/4	zamak	0,330	BF-1063

Single assembly: close side ports (G1/8 - G1/4)
 Manifold assembly with common inlet: close dorsal connections n.1
 With incorporated screws and seal

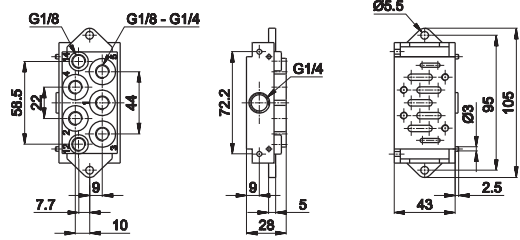

1 = Supply port 3 - 5 = Exhaust
 2 - 4 = Use 12 - 14 = Pilots

ISO 2 - Single sub-base, dorsal connections



Notes	Connection	Material	Weight Kg	Part no.
dorsal connections	G1/4	zamak	0,640	BF-1152
dorsal connections	G3/8	zamak	0,650	BF-1153

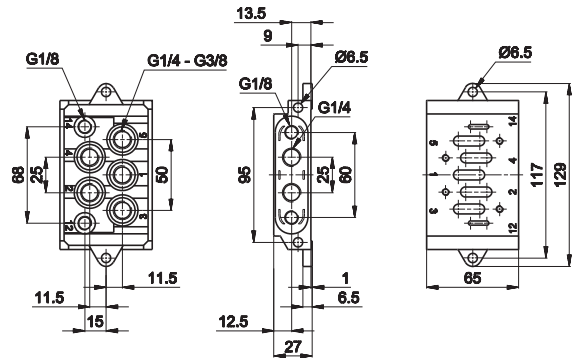

1 = Supply port 3 - 5 = Exhaust
 2 - 4 = Use 12 - 14 = Pilots

ISO 3 - Single sub-base, dorsal connections

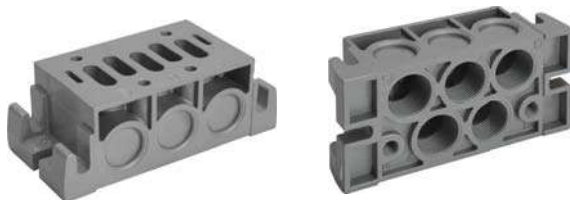

Notes	Connection	Material	Weight Kg	Part no.
dorsal connections	G3/4	aluminium	0,720	BF-3063

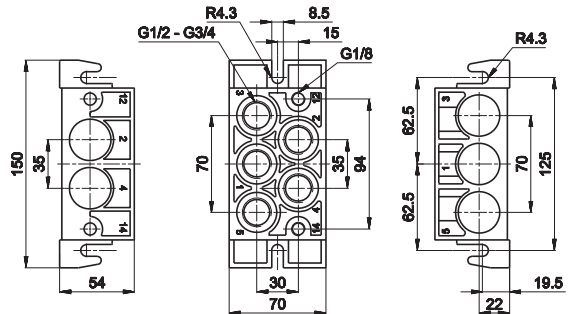

1 = Supply port 3 - 5 = Exhaust
 2 - 4 = Use 12 - 14 = Pilots

ISO 4 - Single sub-base, dorsal connections

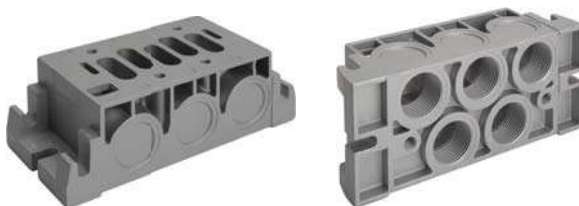

Notes	Connection	Material	Weight Kg	Part no.
dorsal connections	G3/4	aluminium	1,240	BF-4062
dorsal connections	G1	aluminium	1,240	BF-4063

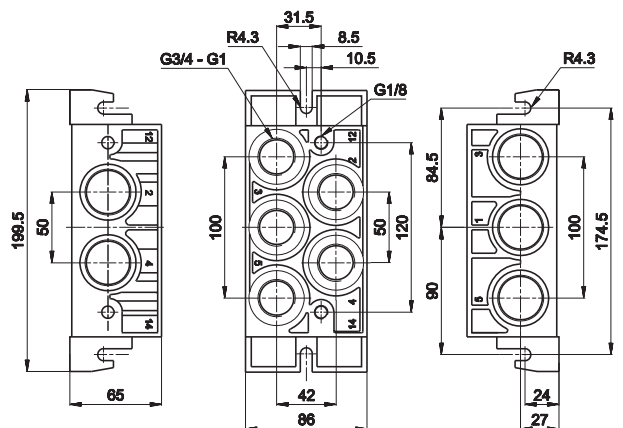

1 = Supply port 3 - 5 = Exhaust
 2 - 4 = Use 12 - 14 = Pilots

2
Standardized valves

ISO 2 - Manifold universal system sub-base, dorsal and side connections, conveyed exhausts

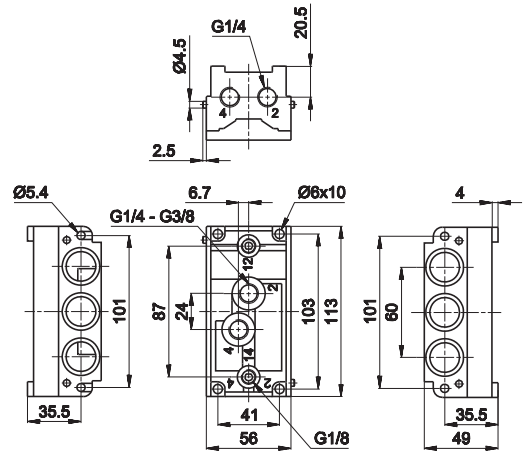

1 = Supply port
2 - 4 = Use
3 - 5 = Exhaust
12 - 14 = Pilots

Notes	Connection	Material	Weight Kg	Part no.
dorsal and side connections	G1/4	zamak	0,800	BF-1160
dorsal and side connections	G3/8	zamak	0,800	BF-1161

Dorsal and side connections possible. Close unused ports with caps.
With incorporated screw, seals and caps included

ISO 2 - Manifold Universal system inlet plate

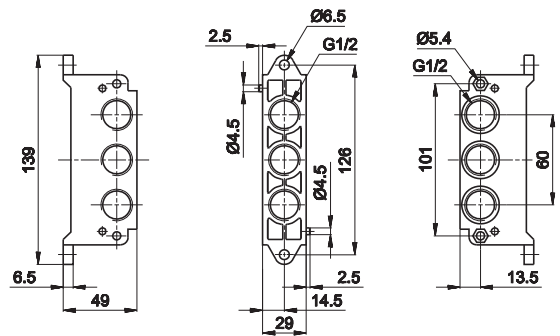

Notes	Connection	Material	Weight Kg	Part no.
in line connections	G1/2	zamak	0,460	BF-1154
dorsal connections	G1/2	zamak	0,460	BF-1155

When battery exceeds 4 units, the mounting of 2 plates is recommended
Mixed version available upon request
With incorporated screw and seals

ISO 2 - Manifold universal system diaphragm

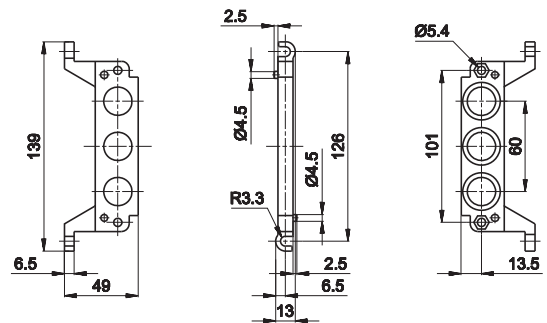

Notes	Connection	Material	Weight Kg	Part no.
-	-	zamak	0,160	BF-1162

The diaphragm is not only the end plate of the manifold but it is also coupled with the exhaust regulator to separate two sub-bases and regulate the valves independently. In this case break the central blind hole.
To get two or more pressures, break the two side blind holes.

BF-1175

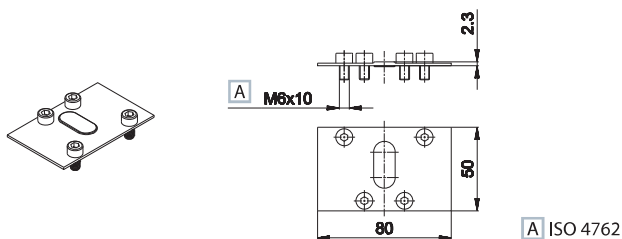

ISO 2 - Closing plate for sub-base 2
material: steel
weight: 0,050 Kg (for all sub-base versions)

ISO 3 - Manifold universal system sub-base, dorsal and side connections, conveyed exhausts

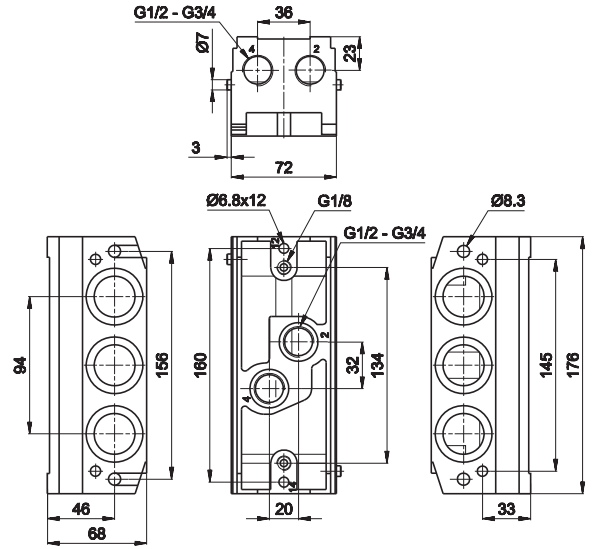

Notes	Connection	Material	Weight Kg	Part no.
dorsal and side connections	G1/2	aluminium	1,100	BF-3071
dorsal and side connections	G3/4	aluminium	1,100	BF-3072

Dorsal and side connections possible. Close unused ports with caps.
With incorporated screws, seals and caps included

1 = Supply port 3 - 5 = Exhaust
2 - 4 = Use 12 - 14 = Pilots

ISO 3 - Manifold Universal system inlet plate

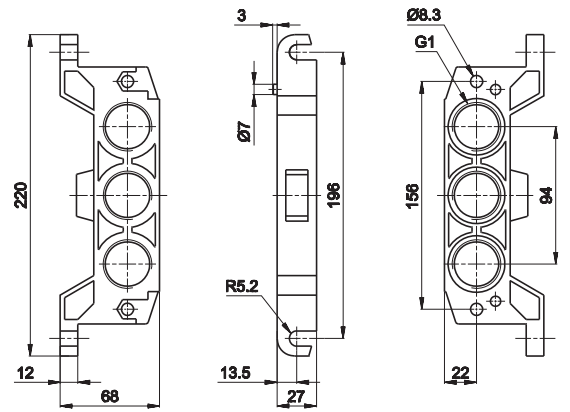

Notes	Connection	Material	Weight Kg	Part no.
in line connections	G1	aluminium	0,440	BF-3064

When battery exceeds 4 units, the mounting of 2 plates is recommended
Mixed version available upon request
With incorporated screws and seals

BF-3175

BF-3082

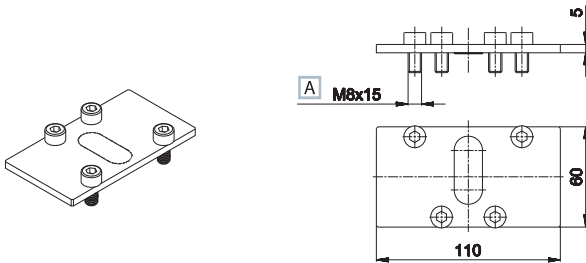

A ISO 4762



ISO 3 - Closing plate for sub-base 3
material: steel
weight: 0,080 Kg (for all sub-base versions)

ISO 3 - Universal system Cap
material: steel
weight: 0,020 Kg
To be used to reach two pressures

BF-1190

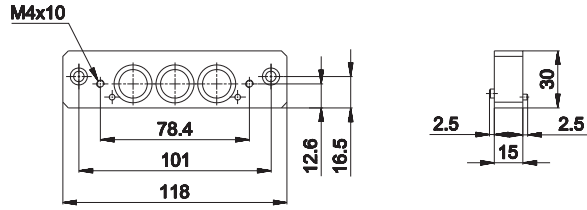
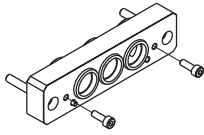

ISO - Connecting interface for universal sub-bases size 1 and 2

material: steel

weight: 0,110 Kg

It allows the use of size 1 and 2 valves in one manifold with conveyed pressure and exhausts. (Upon request: pressure and/or exhausts separated)

BF-3190

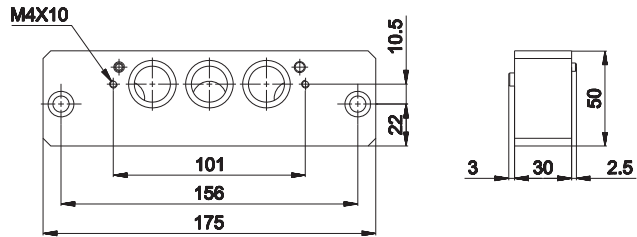
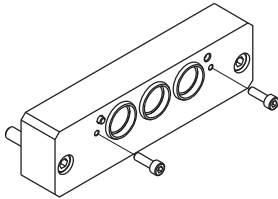

ISO - Connecting interface for universal sub-bases size 2 and 3

material: steel

weight: 0,570 Kg

It allows the use of size 2 and 3 valves in one manifold with conveyed pressure and exhausts. (Upon request: pressure and/or exhausts separated)

BF-3191

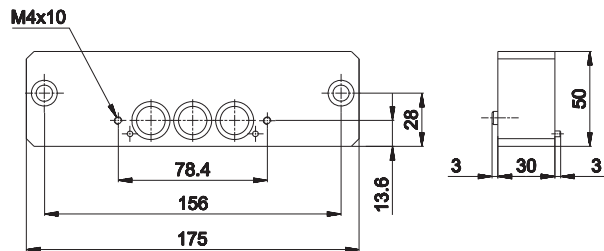
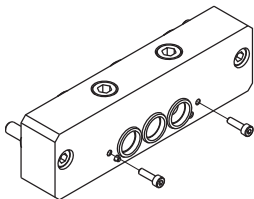

ISO - Connecting interface for universal sub-bases size 1 and 3

material: steel

weight: 0,570 Kg

It allows the use of size 1 and 3 valves in one manifold with conveyed pressure and exhausts. (Upon request: pressure and/or exhausts separated)

