

# AM

## Pneumatic and electric foot valves

- Double poppet system appreciated for its reliability and high flow rate
- Aluminium valve body and pedal lever to the max strenght
- Available with and without protection (in the latter case the protection is to be realized by the machine builder according to the current rules)
- Available with safety devices to prevent unintentional operations
- Available with pneumatic servo-assistance in case of minimum stress
- Electric foot valves with single or double microswitch complete the foot valve range



### TECHNICAL CHARACTERISTICS

Ambient temperature	-10 ÷ +70 °C	
Fluid temperature	-10 ÷ +50 °C	
Fluid	not dehumidified filtered air 50 µm, lubricated or not	
Commutation system	poppet system	
Ways/Positions	<b>2/2 NC, 3/2 NC, 2/2 NO, 3/2 NO, 5/2</b>	
Pressure	max 10 bar	
Control	pedal	
Return	mechanical spring, pedal	
Connections	G1/8	G1/4
Nominal Ø (mm)	2,3	8
Nominal flow rate (NI/min)	98	800

### CONSTRUCTIVE CHARACTERISTICS

#### PNEUMATIC FOOT VALVE:

Valve body	die-cast zamak
Foot valve lever	aluminium
Pedal body and protections	nylon with steel reinforcing plate
Seals	oil/wear-resistant compound
Spool	aluminium

#### ELECTRIC FOOT VALVE:

Valve body, foot valve lever, protections	dielectric plastic material
---	-----------------------------

### Functioning

#### Pedal with spring return

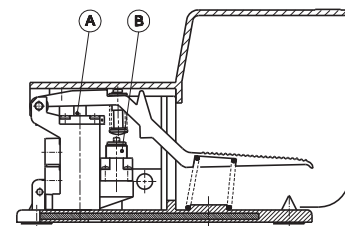

Direct operation A or pneumatic servo-assistance B.

#### Pedal with two positions (bistable)

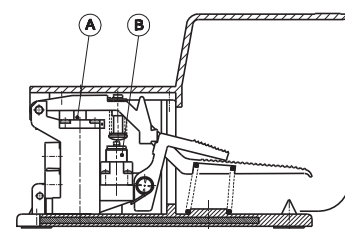

The pedal must be deeply pressed. The unlocking pedal brings the pedal back to the starting position.

#### Pedal with safety device

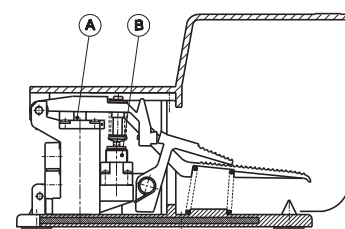

Operation is possible only by pushing both pedals at the same time. Pedals return to the starting position by releasing them. In this case unintentional operation is avoided.

G1/4 pneumatic foot valve with protection

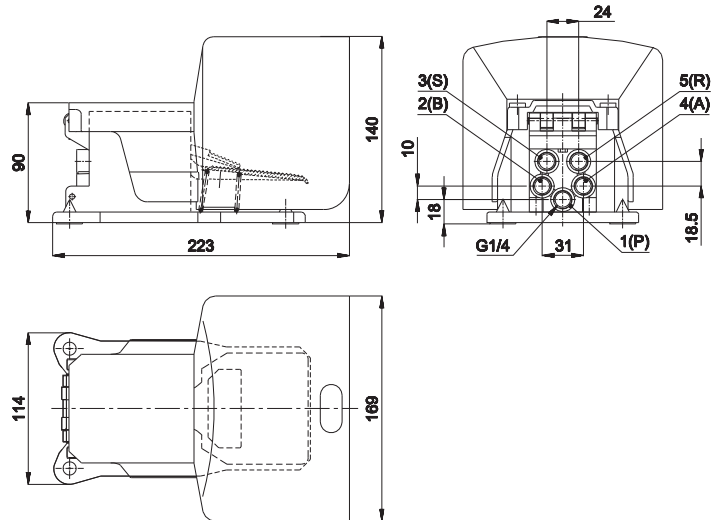

1 (P) = Supply port

2 - 4 (B - A) = Use

3 - 5 (S - R) = Exhaust

Threaded connections for different functions

2/2 NC		2/2 NO		3/2 NC			3/2 NO			5/2				
A	P	B	P	A	P	R	B	P	S	A	B	P	R	S
4	1	2	1	4	1	5	2	1	3	4	2	1	5	3

Symbol	Return	Force N	Weight Kg	Part no.	
<b>SPRING RETURN PEDAL</b>					
3/2 NC		mechanical spring	20	1,25	AM-5000
5/2		mechanical spring	20	1,45	AM-5001
3/2 NO		mechanical spring	20	1,25	AM-5002
<b>BISTABLE PEDAL</b>					
3/2 NC		pedal	20	1,37	AM-5003
5/2		pedal	20	1,52	AM-5004
3/2 NO		pedal	20	1,37	AM-5005
<b>PEDAL WITH SAFETY CONTROL</b>					
5/2		mechanical spring	20	1,45	AM-5011
3/2 NO		mechanical spring	20	1,25	AM-5012
3/2 NC		mechanical spring	20	1,25	AM-5015
<b>SERVOASSISTED PEDAL - SPRING RETURN</b>					
5/2		mechanical spring	20	1,45	AM-5021
<b>SERVOASSISTED BISTABLE PEDAL</b>					
5/2		mechanical spring	20	1,45	AM-5031
<b>SERVOASSISTED PEDAL WITH SAFETY CONTROL</b>					
5/2		mechanical spring	20	1,45	AM-5041

Pneumatic foot valve with orange as standard protection.

G1/4 pneumatic foot valves without protection

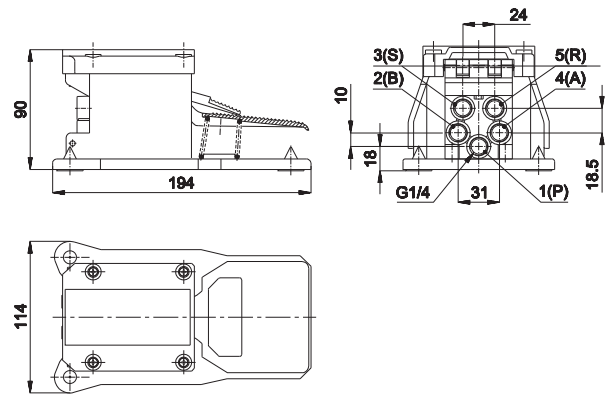

1 (P) = Supply port

2 - 4 (B - A) = Use

3 - 5 (S - R) = Exhaust

Threaded connections for different functions

2/2 NC		2/2 NO		3/2 NC			3/2 NO			5/2				
A	P	B	P	A	P	R	B	P	S	A	B	P	R	S
4	1	2	1	4	1	5	2	1	3	4	2	1	5	3

Symbol	Return	Force N	Weight Kg	Part no.	
<b>PEDAL</b>					
3/2 NC		mechanical spring	20	1,25	AM-5000A
5/2		mechanical spring	20	1,45	AM-5001A
<b>BISTABLE PEDAL</b>					
3/2 NC		pedal	20	1,37	AM-5003A
5/2		pedal	20	1,52	AM-5004A

Other versions upon request.

If this version is used the protection is to be realized by the user according to the current rules.

G1/8 pneumatic foot valves with protection



Symbol	Return	Force N	Weight Kg	Part no.	
<b>PEDAL</b>					
3/2 NC		mechanical spring	20	0,96	AM-5043
2/2 NC		mechanical spring	20	0,96	AM-5043B
3/2 NO		mechanical spring	20	0,96	AM-5043C
2/2 NO		mechanical spring	20	0,96	AM-5043D

Pneumatic foot valve with orange protection.  
Upon request version without protection.

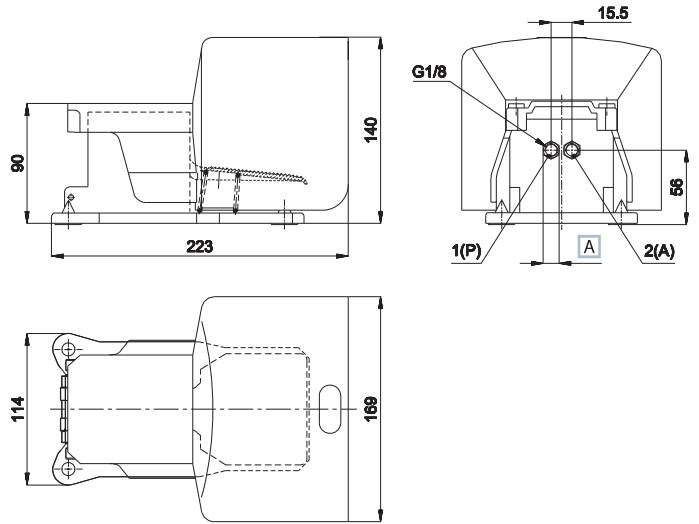

A Wrench 12

1 (P) = Supply port  
2 (A) = Use

Electric foot valves



Symbol	Description	Force N	Weight Kg	Part no.
	pedal without electric microswitch	20	0,86	AM-5050
	pedal with electric microswitch	20	0,92	AM-5051
	pedal with double electric microswitch	20	0,95	AM-5052

Electric foot valve with blue protection.

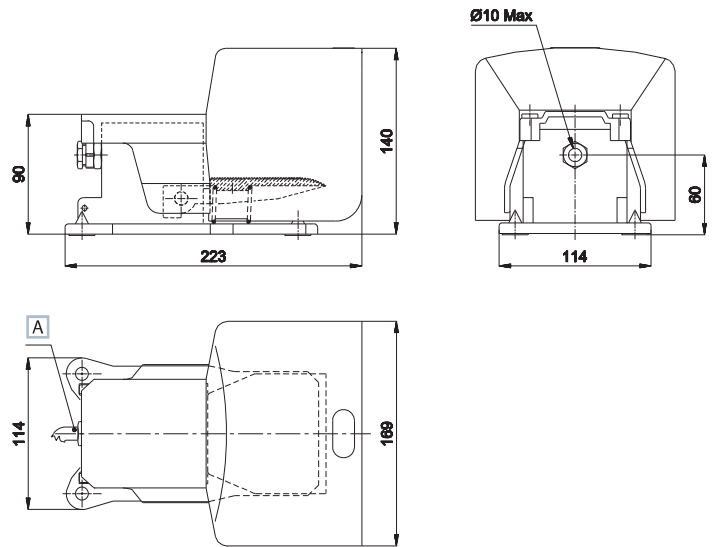

A Electric cable

