

AB

Miniature electropilots U2

Direct intervention electropilots with poppet valve system and bottom cushioned seals

- Assembly on sub-base
- Threaded connections on the body
- CNOMO interface
- Orientable coil (360°) separated from mechanical part
- Versions: 2/2 3/2 - NC NO
- Original Univer SPEED modular sub-base



TECHNICAL CHARACTERISTICS

Ambient temperature	-10 ÷ +50 °C			
Fluid temperature	max +95 °C			
Fluid	filtered air 10 µm, lubricated or not (upon request other fluids can be used)			
Commutation system	direct intervention poppet valve system with cushioned seals			
Ways/Positions	2/2 NC, 3/2 NC, 3/2 NO^(a)			
Pressure	2/2, 3/2 NC = 0 ÷ 10 3/2 NO = 3 ÷ 10			
Control	electric			
Return	mechanical spring			
Connections	on sub-base or with threaded connections on the body			
	sub-base	G 1/8	M5	CNOMO
Nominal Ø (mm)	2,1 ÷ 2,4	2,1 ÷ 2,4	1,6 ÷ 6	2,1 ÷ 2,4
Nominal flow rate (NI/min)	92 ÷ 150	100 ÷ 155	95 ÷ 650	92 ÷ 110

CONSTRUCTIVE CHARACTERISTICS

Materials see features below

ELECTRIC CHARACTERISTICS

Series	U2
Coil	DB
Power consumption	11W (DC) - 10 VA (AC)
Connector	AM 5111
Voltage	12 V DC - 24 V DC - 24 V AC - 110 V AC - 230 V AC

For other electric features see section "Accessories>Coils"

(a) = Mechanical part designed to keep the air supply always from the body
(Useful in case of assembly of more NC-NO pilots in series to have a unique supply port)

U2 Sleeves - with moving core



Material:	
sleeve	treated brass
cores and springs	stainless steel
seals	nitrile rubber

- 3/2 NO
- 3/2 NC
- 2/2 NC (a)
- 2/2 NC

Exhaust Ø mm	Pressure bar	Weight Kg	Part no.
2,4	3÷10	0,060	AB-0600
2,4	0÷10	0,060	AB-0613
-	0÷10	0,060	AB-0640
-	0÷10	0,070	AB-0643

Upon request viton seals and stainless steel sleeves (only NC options)

- NC
- NO

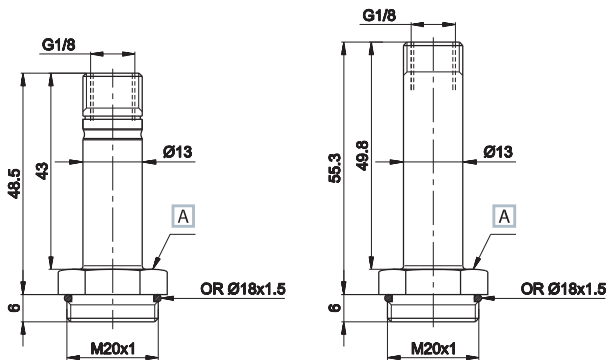

A Wrench 22

Detail of machining

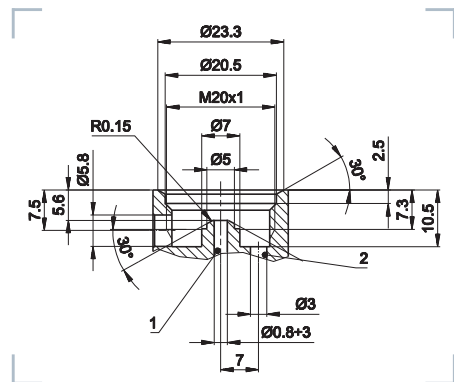

- 1 = Supply port
- 2 = Use

Locking rings for coils on sleeves



Version	Suitable for sleeves	Material	Coil	Part no.
1 = radial exhausts	3/2 NO	technopolymer	U2	AM-5214A
2 = radial exhausts	3/2 NC	technopolymer	U2	AM-5212A
3 = open exhausts	2/2 NC	brass	U2	AM-5212B

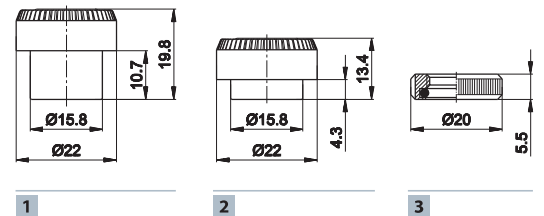

In order to convey exhausts, use version 3

Standard manual overrides with electropilots

Functioning	Suitable for sleeves	Symbol/Part no.
1 = with 2 position screw	all NC U2 electropilots that can use manual override	⊖
2 = with impulse 1-2 position screw	only CNOMO NC U2 electropilots	⊖
3 = with button with tool	only CNOMO NC U2 electropilots	→
4 = with button, 1 position	U2 NO 3/2 electropilots	AM-5203(b)

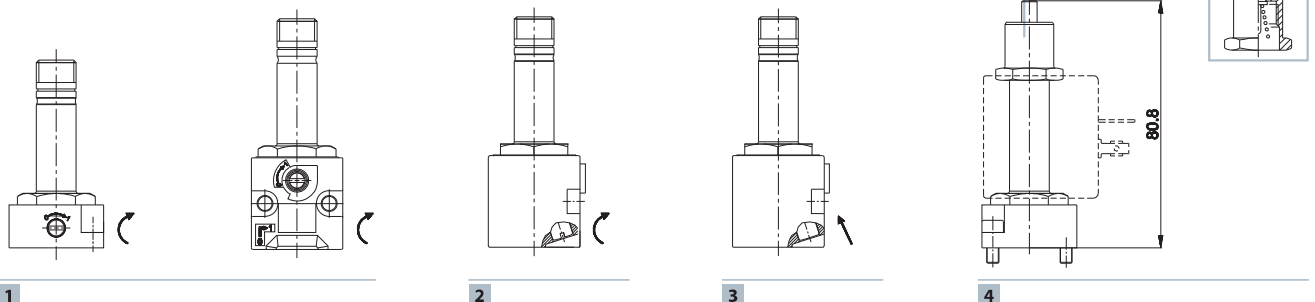

(a) = Suitable for sub-bases with diameter from 3 ÷ 6

(b) = Mounted on the 3/2 NO sleeve

- ⊖ = with 2 position screw
- = with button with tool

U2 2/2 - 3/2 Electropilot for assembling on sub-base



Material:
 valve body zamak
 sleeve treated brass
 core and spring stainless steel
 seals nitrile rubber

Weight (Kg): 0,125

Symbol	Ø (d) mm	Flow rate (NI/min)		Times (ms)		Manual override	Part no.
		1→2	2→3	En.	De-en.		
	2,4	150	160	13	10	—	AB-0681
	2,4	150	160	13	10	⊖	AB-0687
	2,1	130	-	13	-	—	AB-0722
	2,1	130	-	13	-	⊖	AB-0728
	2,4	92	148	14	10	(e)	AB-0685

Sub-base: SPEED U2. Available upon request: stainless steel sleeve - other inner diameters.

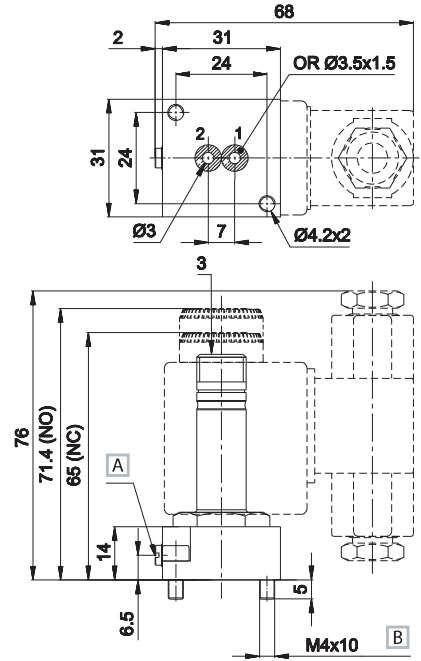

A Manual override
B ISO 4762
 1 = Supply port
 2 = Use
 3 = Exhaust

U2 2/2 - 3/2 G1/8 Electropilot



Material:
 valve body zamak
 sleeve treated brass
 core and spring stainless steel
 seals nitrile rubber

Weight (Kg): 0,145

Symbol	Ø (d) mm	Flow rate (NI/min)		Times (ms)		Manual override	Part no.
		1→2	2→3	En.	De-en.		
	2,4	155	210	13	10	—	AB-0751
	2,4	155	210	13	10	⊖	AB-0757
	2,1	155	-	12	-	—	AB-0765
	2,1	155	-	12	-	⊖	AB-0771
	2,4	100	150	14	11	(e)	AB-0755

Available upon request: stainless steel sleeve - other inner diameters.

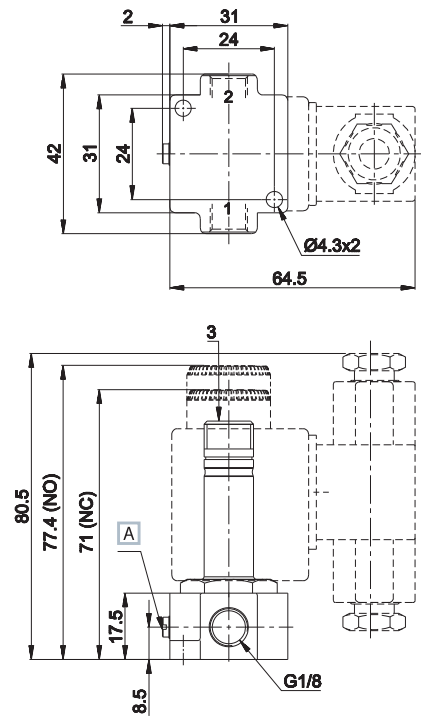

A Manual override
 1 = Supply port
 2 = Use
 3 = Exhaust

(c) = close the exhaust of the 3/2 NO electropilot to get the 2/2 NO one. (d) = the Ø shown on the 3/2 valves refers to the exhhast. ⊖ = with 2 position screw.
 (e) = manual override on AM-5203 ring nut

Electropilots are supplied without coil, connector and locking ring

U2 3/2 G1/4 Electropilot



Material:
 valve body brass
 sleeve treated brass
 core and spring stainless steel
 seals nitrile rubber

Weight (Kg): 0,225

Symbol	Ø (d) mm	Flow rate (NI/min)		Times (ms)		Manual override	Part no.
		1→2	2→3	Ecc.	Dis.		
3/2 NC 	2,1	200	210	13	11	—	AB-0822
3/2 NO (c) 	2,1	95	160	12	10	(e)	AB-0819

Suitable for use with non-aggressive liquids. Upon request: stainless steel body and sleeve.

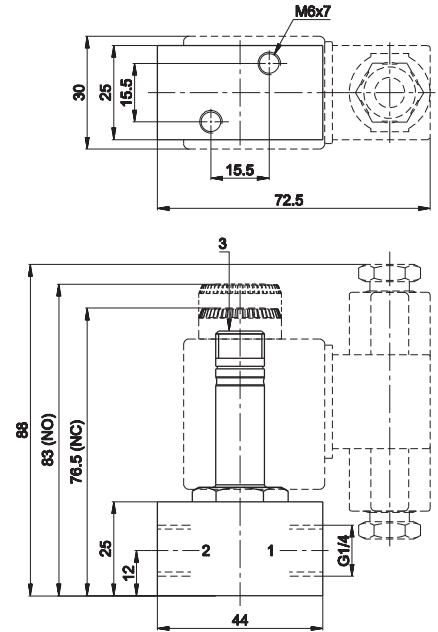

1 = Supply port
 2 = Use
 3 = Exhaust

U2 2/2 G1/4 Electropilot



Material:
 valve body brass
 sleeve treated brass
 core and spring stainless steel
 seals nitrile rubber

Weight (Kg): 0,220

Symbol	Ø (d) mm	Flow rate (NI/min)	Pressure bar	Times (ms)		Part no.
				En.	De-en	
2/2 NC 	1,6	108	0÷30	6	-	AB-0824
	2	165	0÷20	9	-	AB-0825
	2,4	210	0÷15	11	-	AB-0826
	3	280	0÷10	12	-	AB-0827
	3,5	350	0÷9	-	10	AB-0828
	4	450	0÷8	-	13	AB-0829
	4,5	500	0÷7	-	13	AB-0830
	5	550	0÷6,5	-	16	AB-0831
	5,5	600	0÷6	-	21	AB-0832
	6	650	0÷5	-	29	AB-0833

Suitable for use with non-aggressive liquids.

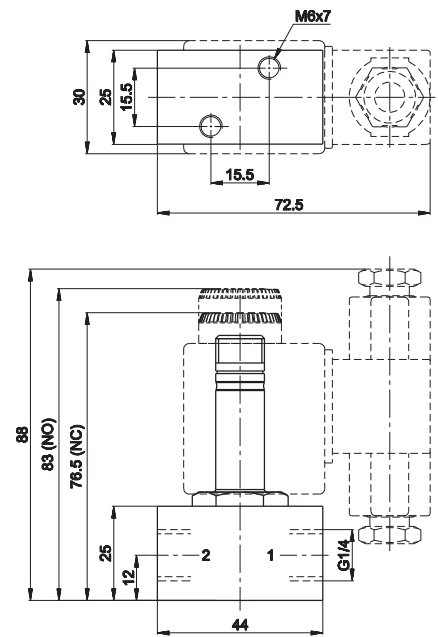

1 = Supply port
 2 = Use

	Coil U2 - 17 VA	Voltage 24V AC - 50/60 Hz DB-0607 110V AC - 50/60 Hz DB-0608 220V AC - 50/60 Hz DB-0610
--	-----------------	--

(c) = close the exhaust of the 3/2 NO electropilot to get the 2/2 NO one. (d) = the Ø shown on the 3/2 valves refers to the exhaust. ⊕ = with 2 position screw.
 (e) = manual override on AM-5203 ring nut

Electropilots are supplied without coil, connector and locking ring

U2 CNOMO 2/2 - 3/2 Electropilot for mounting on sub-bases SPEED U2



Material:	
valve body	technopolymer
sleeve	treated brass
core and spring	stainless steel
seals	nitrile rubber

Weight (Kg): 0,155

Symbol	Ø (d) mm	Flow rate (NI/min)		Times (ms)		Manual override	Part no.
		1 → 2	2 → 3	En.	De-en.		
	2,4	110	170	13	12	⊖	AB-0885
	2,1	115	-	12	-	⊖	AB-0886
	2,4	92	148	13	10	(e)	AB-0888

Sub-base: SPEED U2. Available upon request: brass valve body (without manual override). Zamak valve body. Stainless steel sleeve - other inner diameters.

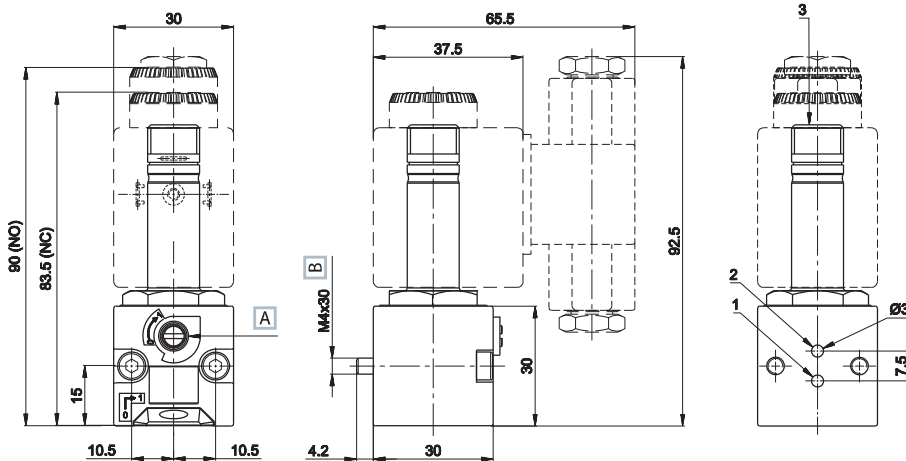

- A Override manual
- B ISO 4762
- 1 = Supply port
- 2 = Use
- 3 = Exhausts

Modular sub-base SPEED series U2 G1/8



Electropilot	Connections	Material	Weight kg	Part no.
U2 for base	G 1/8	zamak	0,075	AB-0900

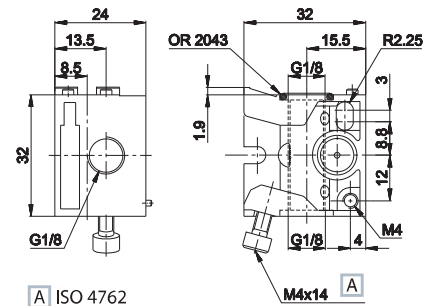

Advantages

The original UNIVER "Speed" series was realized to solve some operational problems

- Possibility of defining the number of sub-bases at the moment of use
- Possibility of freely increasing or reducing the number of elements
- Quick assembly with special screw (built-in) standard supplied
- Reduction of stock holding
- Easy technical intervention

Air supply is rotated by 90° in comparison with side consumption
Standard (built-in) screw and O-Ring

When assembling the manifold, put the bases on a flat surface and tighten the screw until the manifold is perfectly aligned.

(c) = close the exhaust of the 3/2 NO electropilot to get the 2/2 NO one (d) = the Ø shown on the 3/2 valves refers to the exhaust ⊖ = with 2 position screw
(e) = manual override on ring nut AM-5203

Electropilots are supplied without coil, connector and locking ring

U2 G1/8 Sub-base

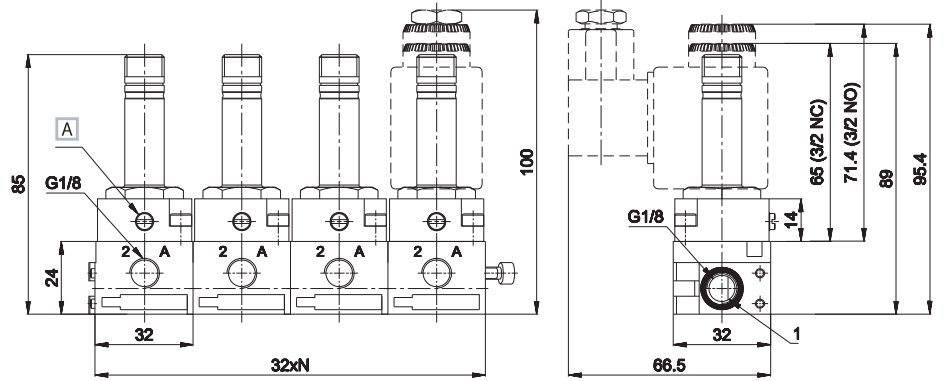

A Manual override

1 = Supply port
2 - A = Use

N = Number of valve position

U2 G1/8 CNOMO Sub-base

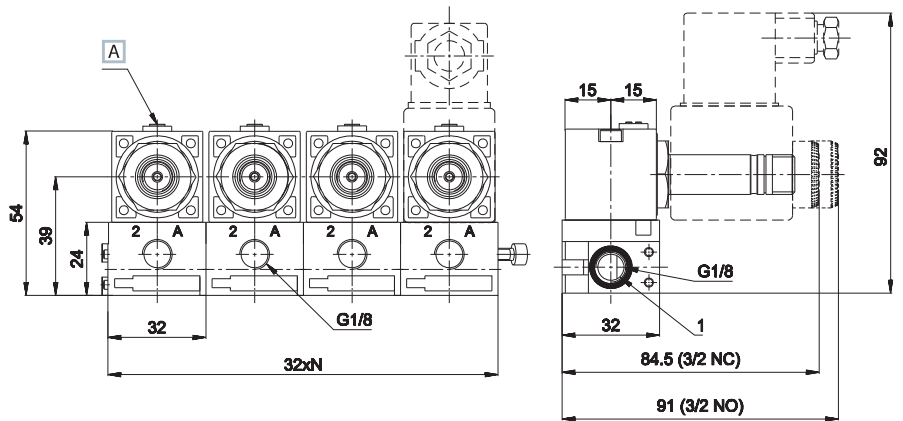

A Manual override

1 = Supply port
2 - A = Use

N = Number of valve position