

A

15 mm Microvalves

- Flow rate max 38 NI/min
- ISO 15218 interface
- 2/2-3/2 versions - normally open (NO) and normally closed (NC)
- Interchangeable coil - 90° orientation
- Single and multiple sub-bases - single and multipolar electric connection



TECHNICAL CHARACTERISTICS

Ambient temperature	-5 ÷ +50 °C	
Fluid temperature	max +50 °C	
Fluid	10 µm filtered air, lubricated or not	
Commutation system	poppet	
Ways/Positions	2/2 NC, 3/2 NC, 2/2 NO, 3/2 NO	
Pressure	max 9 bar	
Control	electric	
Return	mechanical spring	
Connections	ISO 15218 interface	
Nominal Ø	1,2	1,5
Nominal flow rate	26	38
Max frequency	2700 cycles/min	

CONSTRUCTIVE CHARACTERISTICS

Valve body	technopolymer (aluminium external cover)
Seals	nitrile rubber
Components	stainless steel, brass

ELECTRIC CHARACTERISTICS

Coil	U05 DD series	
Power consumption	24 V AC - 48 V AC - 110 V AC - 230 V AC	
Electrical connection	15 mm connector - Molex-type bipolar connector or loose wires	
Voltage	12 V DC - 24 V DC	
Manual override	with button with tool	
	(upon request other manual overrides, see page 1_5)	
Protection degree with connector	IP65	

ISO 15218 Substructure

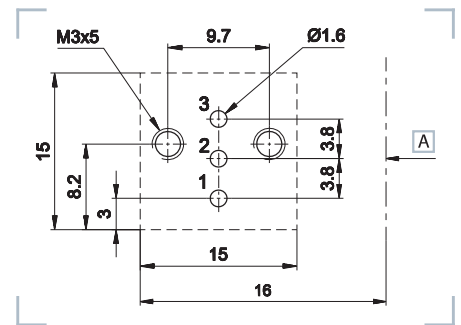

[A] Pitch

3/2 NC

- 1 = Supply port
- 2 = Use
- 3 = Exhaust

3/2 NO

- 1 = Exhaust
- 2 = Use
- 3 = Supply port

2/2 NO

- 1 = Exhaust
- 3 = Supply port

Drilling jig to assemble the valve on a smooth surface with a sealing plate in between. Part no. A-299-11.

15 mm Microvalves

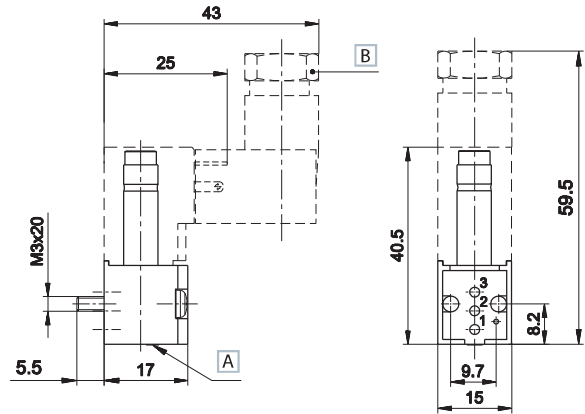

A Manual override

B Possible rotation by 180°

3/2 NC	3/2 NO	2/2 NO
1 = Supply port	1 = Exhaust	1 = Exhaust
2 = Use	2 = Use	3 = Supply port
3 = Exhaust	3 = Supply port	

Microvalves Ø 1,2 for direct current coils 2 W

	Symbol	Pressure bar	Ø mm	Flow rate NI/min.	Current	Times (ms)		Weight (b) Kg	Part no.	Suggested coils	
						En.	De-en.				
2/2 NC		0÷9	1,2	26	DC	11	11	0,018 (0,037)	A-141N	DD-051 24 V DC - 2 W	Coil with Faston
2/2 NO		0÷9	1,2	26	DC	11	11	0,018 (0,037)	A-161N	DD-051L030 24 V DC - 2 W	Coil with flying cables
3/2 NC		0÷9	1,2	26	DC	11	11	0,018 (0,037)	A-101N	Upon request 12 V DC	
3/2 NO		0÷9	1,2	26	DC	11	11	0,018 (0,037)	A-121N		

Microvalves Ø 1,5 for direct current coils 2,5 W

	Symbol	Pressure bar	Ø mm	Flow rate NI/min.	Current	Times (ms)		Weight (b) Kg	Part no.	Suggested coils	
						En.	De-en.				
2/2 NC		0÷8	1,5	38	DC	11	11	0,018 (0,037)	A-142N	DD-052 24 V DC - 2,5 W	Coil with Faston
2/2 NO		0÷8	1,5	38	DC	11	11	0,018 (0,037)	A-162N	DD-052L030 24 V DC - 2,5 W	Coil with flying cables
3/2 NC		0÷8	1,5	38	DC	11	11	0,018 (0,037)	A-102N	Upon request 12 V DC	
3/2 NO		0÷8	1,5	38	DC	11	11	0,018 (0,037)	A-122N		

Microvalves Ø 1,2 for direct or alternate current

	Symbol	Pressure bar	Ø mm	Flow rate NI/min.	Current	Times (ms)		Weight (b) Kg	Part no.	Suggested coils	
						En.	De-en.				
2/2 NC		0÷9	1,2	26	DC/AC	11	11	0,018 (0,037)	A-151N	DD-040 24 V AC - 50/60 Hz - 2 VA	Coil with Faston
2/2 NO		0÷9	1,2	26	DC/AC	11	11	0,018 (0,037)	A-171N	DD-050 48 V AC - 50/60 Hz - 2 VA	
3/2 NC		0÷9	1,2	26	DC/AC	11	11	0,018 (0,037)	A-111N	DD-051 24 V DC - 2 W	
3/2 NO		0÷9	1,2	26	DC/AC	11	11	0,018 (0,037)	A-131N	DD-070 230 V AC - 50/60 Hz - 2 VA	
										DD-051L030 24 V DC - 2 W	Coil with flying cables

(b) = the weight in brackets refers to coil with faston

For technical data of coils see "Accessories>Coils"

Pilots are supplied without coil, connector and sealing plate

Upon request 12 V DC

Microvalves Ø 1,5 for direct or alternate current

	Symbol	Pressure bar	Ø mm	Flow rate NI/min.	Current	Times (ms)		Weight (b) Kg	Part no.	Suggested coils	
						En.	De-en.				
2/2 NC		0÷9	1,5	38	DC/AC	11	11	0,018 (0,037)	A-152N	DD-011 24 V AC - 50/60 Hz DD-013 220 V AC - 50/60 Hz - 3,5 VA DD-040 24 V AC - 50/60 Hz - 3,5 VA DD-052 24 V DC - 2,5 W DD-060 48 VAC - 50/60 Hz - 3,5 VA	Coil with Faston
3/2 NC		0÷9	1,5	38	DC/AC	11	11	0,018 (0,037)	A-112N	DD-052L030 24 V DC - 2,5 W	Coil with flying cables

Upon request 12 V DC

>> Coils



U5 flying cables
weight: 0,019 Kg
DD-051L030
DD-052L030

U05 15 mm
weight: 0,019 Kg
DD-011 **DD-051**
DD-013 **DD-052**
DD-040 **DD-060**
DD-041 **DD-070**
DD-050

Standard manual override

Operation	Notes	Symbol
1 = with button with tool, 1 position (standard)	metallic	→
2 = with button, 1-2 positions (upon request)	technopolymer red colour	⊖
3 = with front button, 1 position (upon request)	technopolymer red colour	→
4 = with button, 1 position (upon request)	metallic	→

1

2

3

4

(b) = the weight in brackets refers to coil with faston

For technical data of coils see "Accessories>Coils"

Pilots are supplied without coil, connector and sealing plate

Sub-base for external electric connection

Sub-base in extruded anodized aluminium with conveyed supplies and exhausts for assembling NC or NO valves. If NC and NO valves are assembled on just one base, it is necessary to insert the inverter part A-350 for NO valves.

- A - 326A - __^(b) G1/8 threaded connections (standard)
- A - 326B - __^(b) M5 threaded connections (upon request)
- A - 326C - __^(b) push-in connections tube 3 (upon request)
- A - 326D - __^(b) push-in connections tube 4 (upon request)

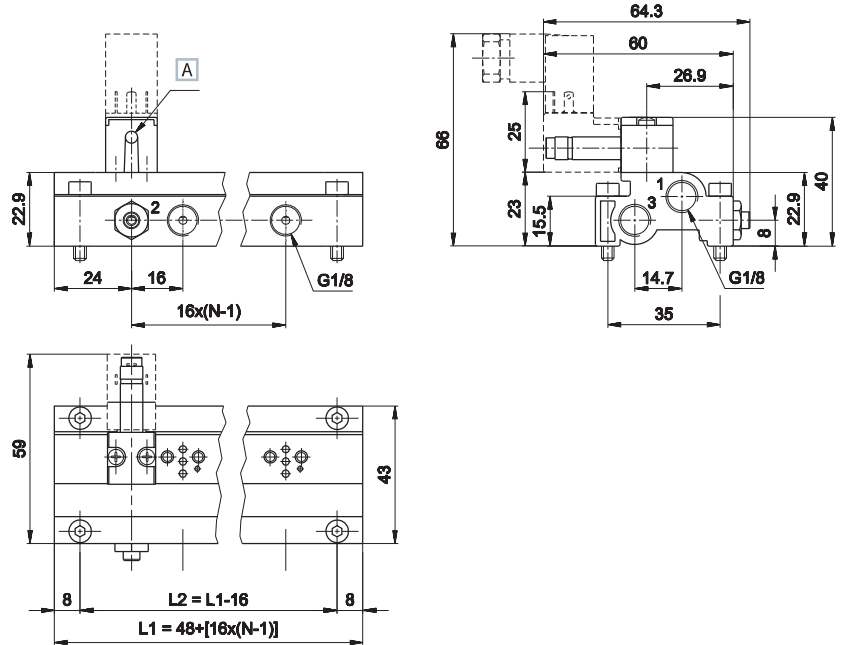

A Manual override

N = Number of valve positions
(b) = Number of positions

3/2 NC

- 1 = Supply port
- 2 = Use
- 3 = Exhaust

3/2 NO

- 1 = Exhaust
- 2 = Use
- 3 = Supply port

2/2 NO

- 1 = Exhaust
- 3 = Supply port

Sub-base for integrated electric connection

Sub-base with sub-D connector in extruded anodized aluminium up to max. 13 stations with connector 15 pin (upon request up to 23 with connector 25 pin) and G1/8 threaded standard connections, with conveyed supplies and exhausts for assembling NC or NO valves with integrated coil connection and optical indication of the valve activation. If both, NO and NC valves, are assembled on just one sub-base, NC valves are always mounted on the connector side and afterwards the NO valves. The invert (part no. A-350) is inserted for NO valves.

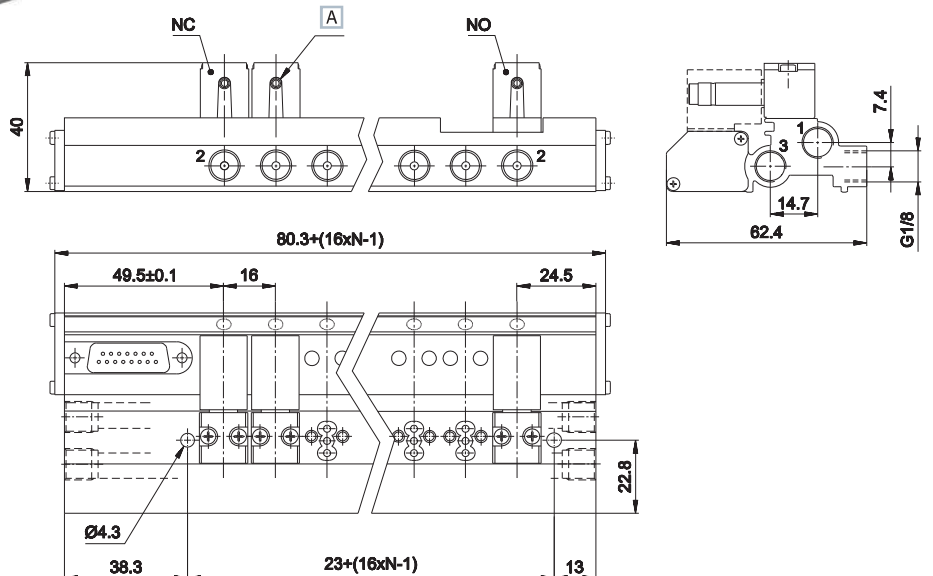

A Manual override

N = Number of valve positions

3/2 NC

- 1 = Supply port
- 2 = Use
- 3 = Exhaust

3/2 NO

- 1 = Exhaust
- 2 = Use
- 3 = Supply port

2/2 NO

- 1 = Exhaust
- 3 = Supply port

A-299-11

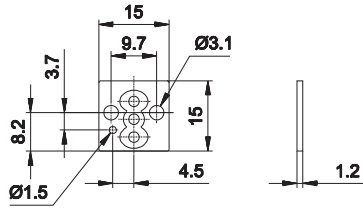
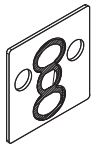

Sealing plate

It blocks the seal in place when the valve is mounted on a smooth surface without a seal housing
 material: aluminium
 weight: 0,003 Kg

A-301

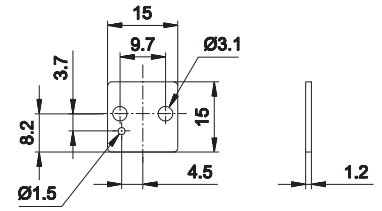
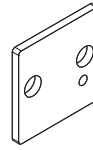

Blank plate

Unused valve stations must be closed with the blanking plate
 material: aluminium
 weight: 0,002 Kg

A-305

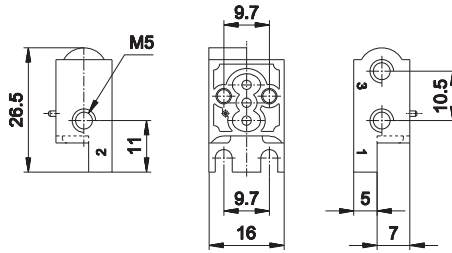
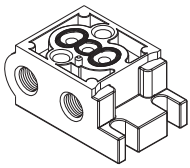

Single base

material: zamak
 connection: M5
 weight: 0,012 Kg

A-350

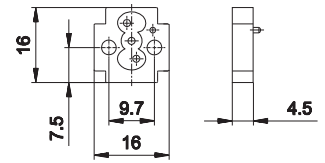
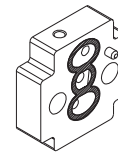

Inverter

NO and NC valves can be mounted on a single block inserting this device between the NO valve and the sub-base.
 If all are NO valves, just invert air supply, without using the inverter.
 material: plastic
 weight: 0,002 Kg

