

NEW
Ø 25

Standard supplied with:
Non rotating piston rod
Elastic bumpers
Flange
Magnetic version*

* The sensor on the barrel detects the position only of the 1st stage and not of the successive ones, both in forward and reverse movement (excluded version with telescopic magnet holder).

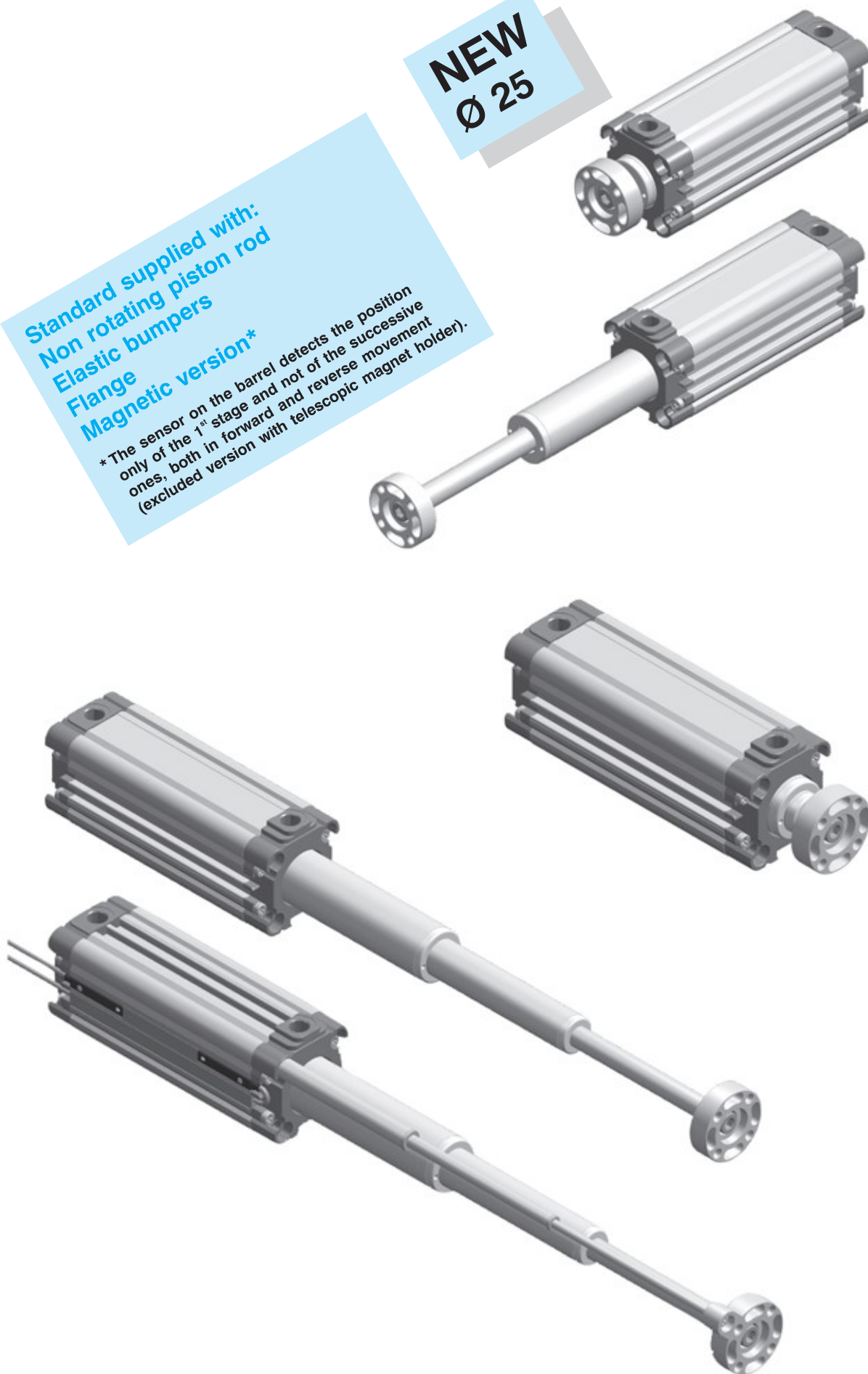



Considering its high technological contents, this cylinder series represents without doubt the product with the highest degree of technical research and evolution accomplished by the technicians of the company. The overall dimensions are one of the most important aspects: in comparison with a traditional ISO cylinder of the same stroke a reduction in size of approx. 45% (with a 3-stage telescopic cylinder) is obtained thus permitting the customer to foresee a considerable reduction of the project and construction of his equipment. The cylinder can be supplied in magnetic version and with slide unit (only for 2-stage version).

TECHNICAL CHARACTERISTICS

Working pressure: 1,5 ÷ 10 bar
 Ambient temperature: -20°C ÷ 80°C
 Fluid: filtered air, lubricated or not.
 Barrel: in aluminium, internally/externally anodized.
 Non-rotating rod in chromium-plated steel with standard supplied flange except for version with male rod.
 Elastic bumpers.
 Magnetic version with detection of position of the 1st stage only.

Upon request

- Magnetic sensor DF-... (page 2-V).
- Wire protection strap for magnetic sensor.
- Magnetic version 2-3 stages with telescopic magnet holder prearranged only for end-stroke reading (except for Ø 25 mm).
- Slide unit only for 2-stage telescopic cylinder. (page 55-II).



Table summarizing bore combinations

Telescopic cylinder	Ø I° stage	Ø II° stage	Ø III° stage
25	25	16	-
32	32	20	-
40	40	25	16
50	50	32	20
63	63	40	25

Codification key

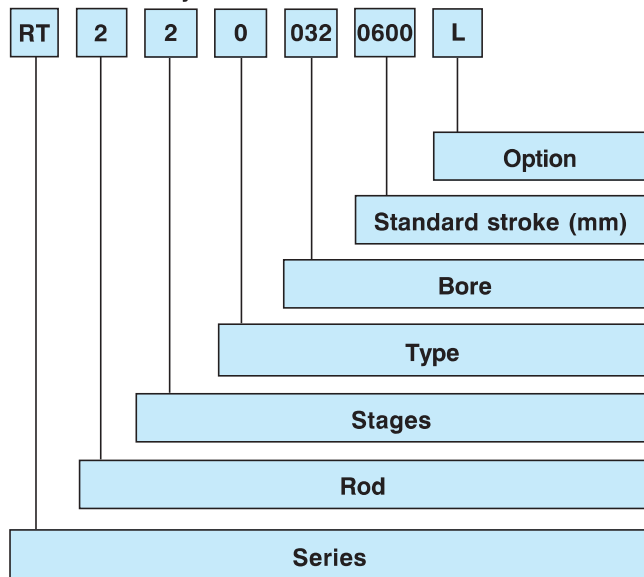

SERIES

Telescopic pneumatic cylinder in magnetic version with non-rotating piston rod, elastic bumpers and flange, Ø 25 ÷ 063 mm

ROD

- 2... chromium-plated steel
- 1... stainless steel

STAGES

- 2... 2 stages
- 3... 3 stages

TYPE

- 0 = D.A. inter-axes female rod
- 3 = D.A. inter-axes male rod

BORE

- 2 stages: Ø 025-032-040-050-063 mm
- 3 stages: Ø 040-050-063 mm

STANDARD STROKE

- 2 Stages**
 0100-0120-0160-0180-0200-0300-0400-0500-0600-0700
 0800-0900-1000-1100-1200
 Max stroke: Ø 25 **0300 mm**
 Ø 32 **0400 mm**
 Ø 40 **0600 mm**
 Ø 50 **0900 mm**
 Ø 63 **1200 mm**

- 3 Stages**
 0150-0180-0210-0240-0270-0300-0360-0450-0600-0750
 0900-1050-1200-1500-1800
 Max stroke: Ø 40 **1200 mm**
 Ø 50 **1500 mm**
 Ø 63 **1800 mm**

OPTION

- I = Without flange (only for female piston rod).
- L = Freely rotating rod.
- M = With telescopic magnetic holder for 2nd-3rd stage (except for Ø 25 mm).

2-stage telescopic cylinders Theoretical forces in N (0,102 Kg)

2-stage telescopic cylinder	Useful surface (mm ²)	Working pressure (bar)					
		2	4	6	8	10	
25	thrust	201	41	82	123	164	205
	traction	111	22	43	65	87	108
32	thrust	314	64	128	192	256	320
	traction	201	41	82	123	164	205
40	thrust	490	100	200	300	400	500
	traction	377	77	154	231	308	384
50	thrust	804	164	328	492	656	820
	traction	603	123	246	369	492	615
63	thrust	1256	256	512	769	1025	1281
	traction	1055	215	430	646	861	1076

3-stage telescopic cylinders Theoretical forces in N (0,102 Kg)

3-stage telescopic cylinder	Useful surface (mm ²)	Working pressure (bar)					
		2	4	6	8	10	
40	thrust	201	41	82	123	164	205
	traction	111	22	43	65	87	108
50	thrust	314	64	128	192	256	320
	traction	201	41	82	123	164	205
63	thrust	490	100	200	300	400	500
	traction	377	77	154	231	308	384

Maximum applicable torque [Nm] for non-rotating rod

Cyl. Ø	Torque	
	2 stages	3 stages
25	0,5	-
32	0,8	-
40	1	0,5
50	2	0,8
63	3	1

Nominal tolerances on stroke (mm)

Cyl. Ø	Tolerance	
	2 stages	3 stages
25	+ 2/0	
32		
40	+ 3,2/0	+ 4/0
50		
63		

The telescopic cylinder works in optimal conditions when the load is axial, i.e. with the cylinder placed vertically, upwards or downwards. Naturally it can also work horizontally and cantilevered. However in this case:

- the maximum strokes have to be reduced by 50% as compared to the maximum rated ones.
- request cylinders with slide units.
- the radial load has to be supported by other systems (carriage, slides, sliding guides).

The following example shows the relation of dimensions between the cylinder types having the same stroke of 300 mm.

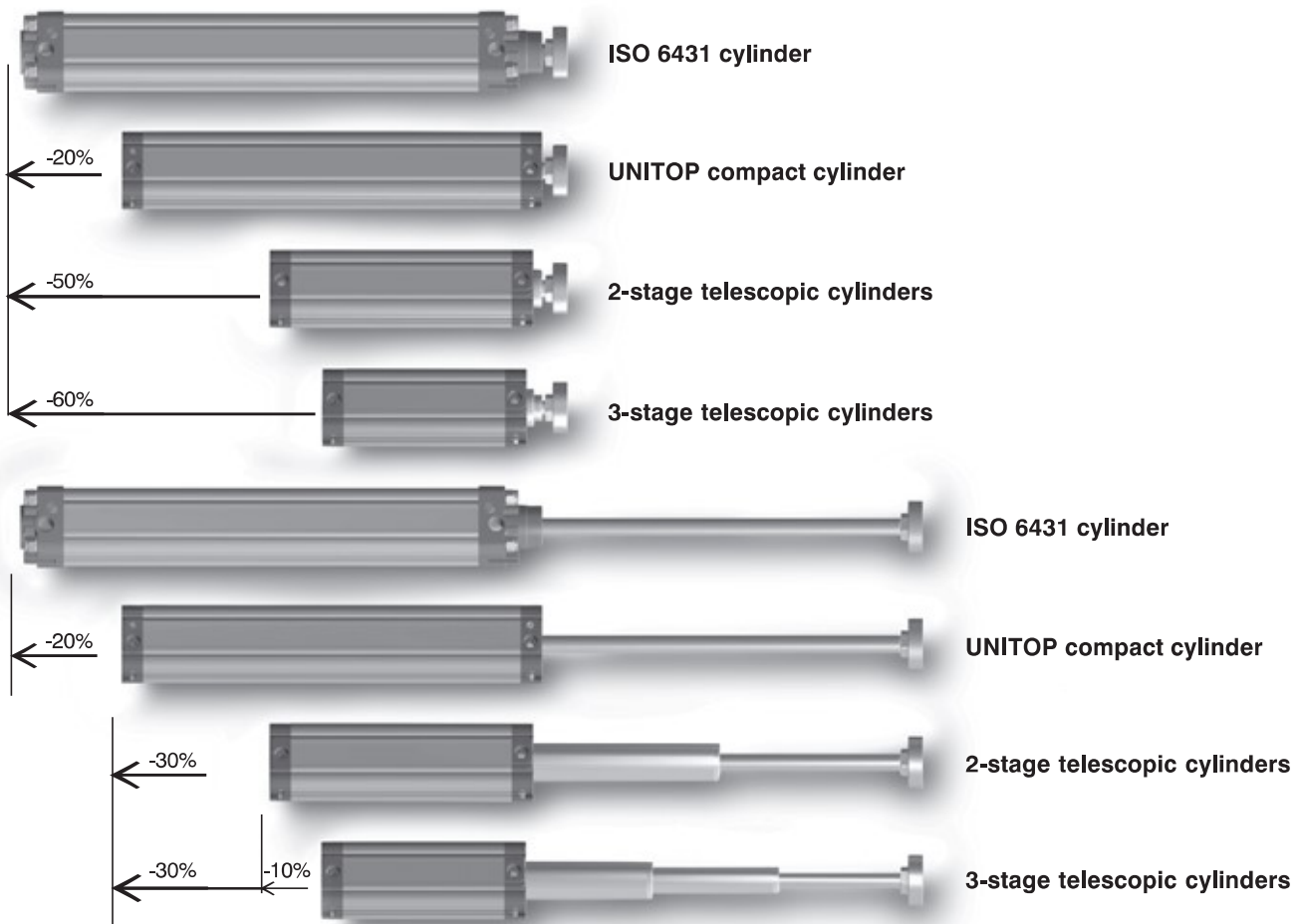



2-stage telescopic cylinder with flange RT220...

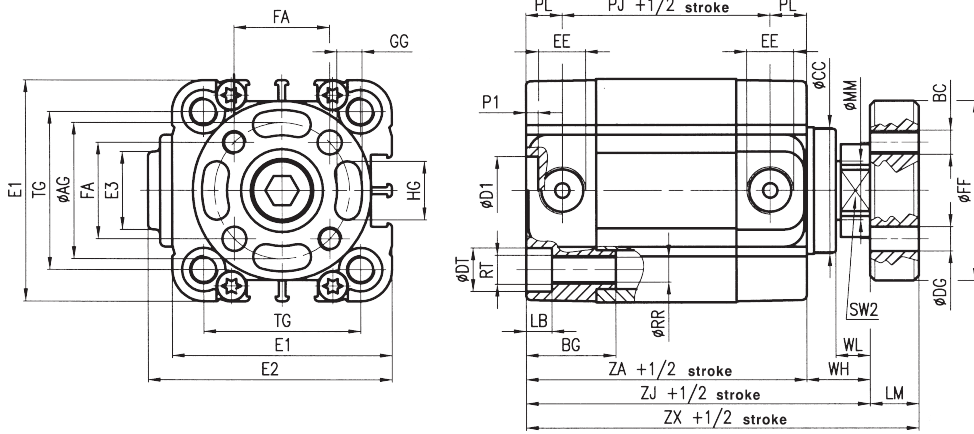

2-stage telescopic cylinder magnetic version RT220...M

(*) Note: the magnetic sensor DF... may only be placed near the telescopic magnet holder stem (as shown in the drawing).

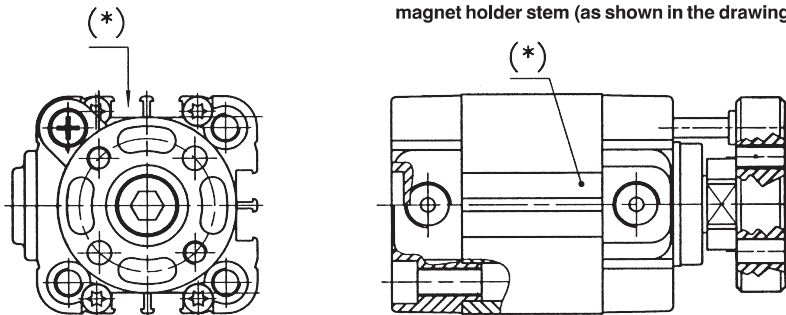

2-stage telescopic cylinder without flange RT220...I

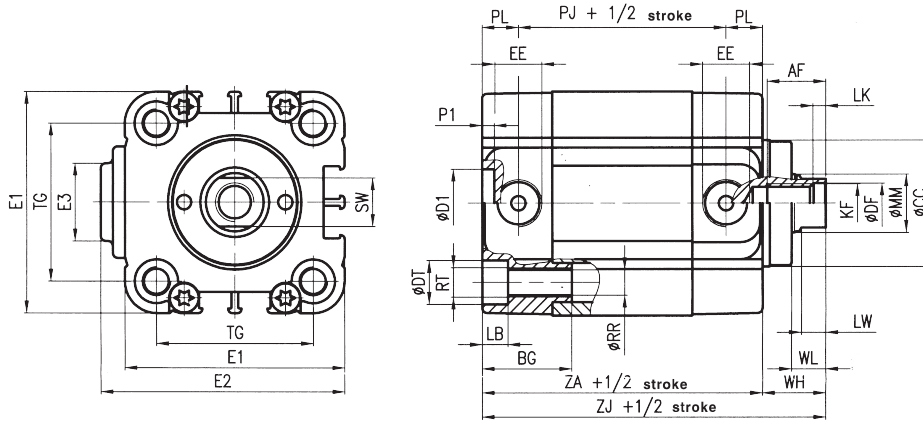

2-stage telescopic cylinder with male rod RT223...

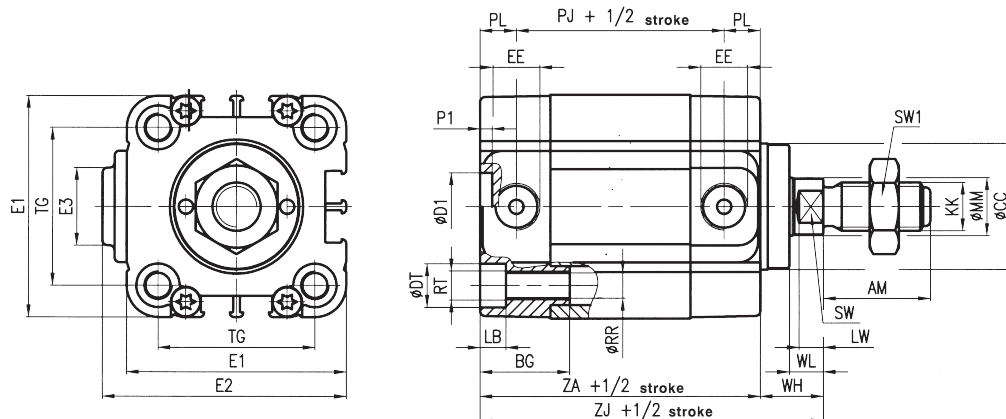

Cyl. Ø	AF	Ø AG	AM	BC	BG	Ø CC	ØD1 H11	Ø DF	Ø DG	Ø DT	E1	E2	E3	EE	FA	Ø FF	GG	HG	KF
25	10	22	22	M5	16	22	2	6,1	5	8	37	39	18	M5	15,6	30	5	9	M6
32	12	28	22	M5	18	26	14	8,2	5	9	46	50,5	16	G1/8	19,8	37	5,2	11	M8
40	12	33	22	M5	18	32	14	8,2	5	9	56	60,5	16	G1/8	23,3	42	5,2	15	M8
50	16	42	24	M6	24	40	18	10,2	6	11	66	70,5	16	G1/8	29,7	52	6,2	19	M10
63	16	50	24	M6	24	48	18	10,2	6	11	79	83,5	38	G1/8	35,4	64	6,2	25	M10

Cyl. Ø	KK	LB	LK	LM	LW	Ø MM	P1	PJ	PL	Ø RR	RT	SW	SW1	SW2	TG	WH	WL	ZA	ZJ	ZX
25	M10X1,25	4,5	1	8	4,5	10	2	32	8	4,2	M5	8	17	-	26	17	7	48	65	73
32	M10X1,25	5,3	2	10	5	12	2,5	43	7,5	5,2	M6	10	17	17	32,5	13	7	58	71	81
40	M10X1,25	5,3	2	10	5	12	2,5	45	7,5	5,2	M6	10	17	19	38	12	7	60	72	82
50	M12X1,25	6,5	2	12	6	16	2,5	46	7,5	6,6	M8	13	19	24	46,5	15	8	61	76	88
63	M12X1,25	6,5	2	12	6	16	2,5	50	7,5	6,6	M8	13	19	24	56,5	15	8	65	80	92

Mass

RT220...

Cyl. Ø	Cylinder "0" stroke (g)	Increase per mm stroke (g)	Moving parts "0" stroke (g)	Increase per mm stroke (g)
25	200	2,45	74,2	1,2
32	270	3,02	124,6	1,4
40	419	3,77	182	1,6
50	640	5,28	314	2,6
63	1005	6,33	480	2,72

RT220...M

Cyl. Ø	Cylinder "0" stroke (g)	Increase per mm stroke (g)	Moving parts "0" stroke (g)	Increase per mm stroke (g)
32	245	3,02	137,6	1,5
40	380	3,77	188,5	1,7
50	572	5,28	318	2,7
63	910	6,33	487	2,8

RT220...I

Cyl. Ø	Cylinder "0" stroke (g)	Increase per mm stroke (g)	Moving parts "0" stroke (g)	Increase per mm stroke (g)
25	238	2,45	67,2	1,2
32	245	3,02	99,6	1,4
40	380	3,77	142,5	1,6
50	572	5,28	246	2,6
63	910	6,33	385	2,72

RT223...

Cyl. Ø	Cylinder "0" stroke (g)	Increase per mm stroke (g)	Moving parts "0" stroke (g)	Increase per mm stroke (g)
25	270	2,45	79,2	1,2
32	275	3,02	129,6	1,4
40	410	3,77	172,5	1,6
50	617	5,28	291	2,6
63	955	6,33	430	2,72



3-stage telescopic cylinder with flange RT230...

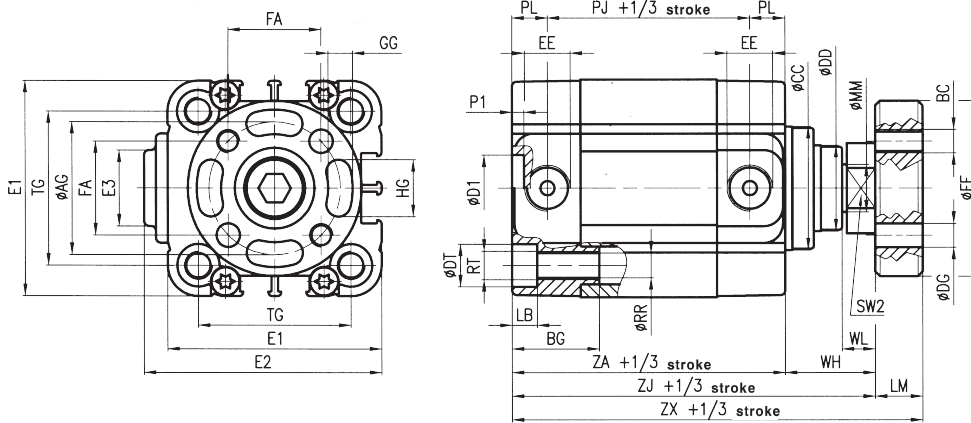

3-stage telescopic cylinder magnetic version RT230...M

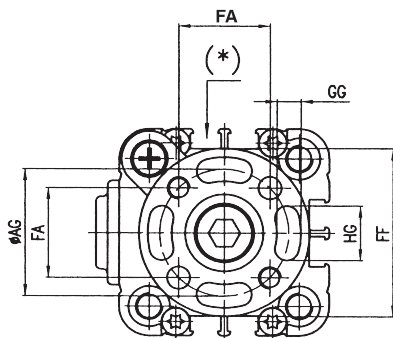

(*) Note: the magnetic sensor DF... may only be placed near the telescopic magnet holder stem (as shown in the drawing).

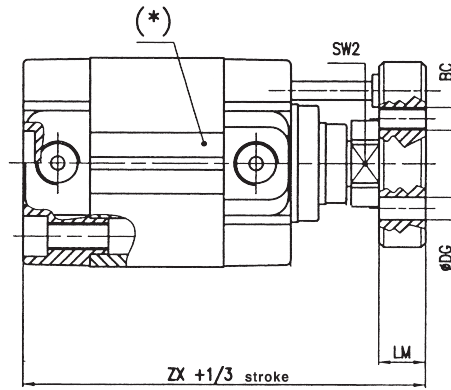

3-stage telescopic cylinder without flange RT230...I

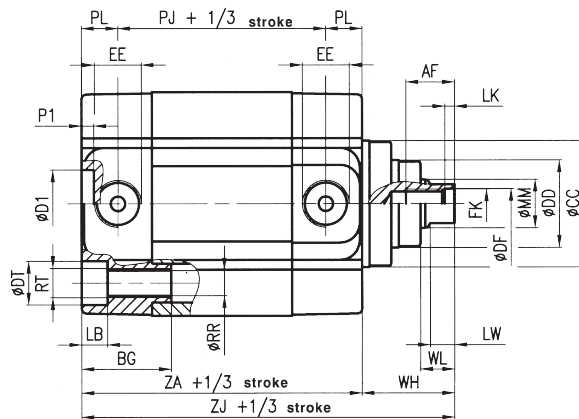
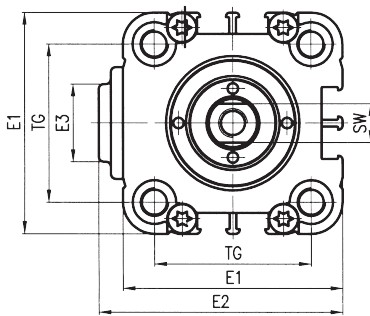

3-stage telescopic cylinder with male rod RT233...

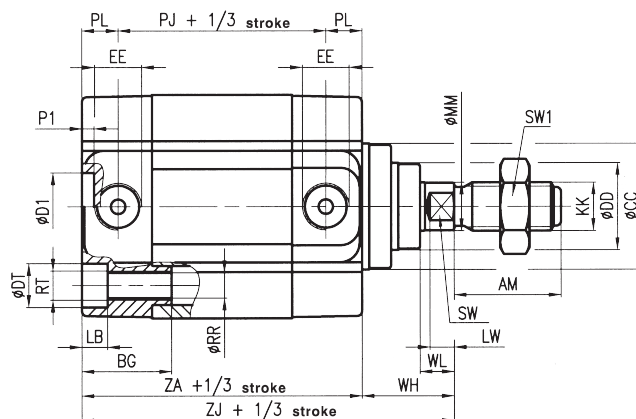
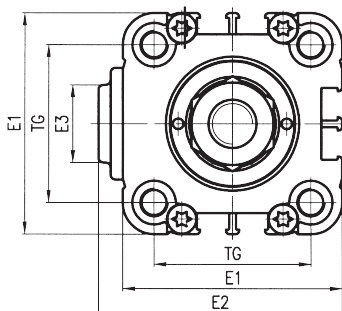

Cyl. Ø	AF	Ø AG	AM	BC	BG	Ø CC	ØD1 H11	Ø DD	Ø DF	Ø DG	Ø DT	E1	E2	E3	EE	FA	Ø FF	GG	HG	KF
40	10	28	22	M5	18	32	14	22	6,2	5	9	56	60,5	16	G1/8	19,8	37	5,2	11	M6
50	12	28	22	M5	24	40	18	26	8,2	5	11	66	70,5	16	G1/8	19,8	37	5,2	11	M8
63	12	33	22	M5	24	48	18	32	8,2	5	11	79	83,5	38	G1/8	23,3	42	5,2	15	M8

Cyl. Ø	KK	LB	LK	LM	LW	Ø MM	P1	PJ	PL	Ø RR	RT	SW	SW1	SW2	TG	WH	WL	ZA	ZJ	ZX
40	M10X1,25	5,3	2	10	5	10	2,5	45	7,5	5,2	M6	8	17	17	38	22	7	60	82	92
50	M10X1,25	6,5	2	10	5	12	2,5	46	7,5	6,6	M8	10	17	17	46,5	24	7	61	85	95
63	M10X1,25	6,5	2	10	5	12	2,5	50	7,5	6,6	M8	10	17	19	56,5	25	7	65	90	100

Dimensional variations for RT230...M series

Cyl. Ø	Ø AG	BC	Ø DG	FA	Ø FF	GG	HG	LM	SW2	ZX
40	33	M5	5	23,3	42	5,2	15	10	19	92
50	42	M6	6	29,7	52	6,2	19	12	24	97
63	50	M6	6	35,4	64	6,2	25	12	24	102

Mass

RT230...

Cyl. Ø	Cylinder "0" stroke (g)	Increase per mm stroke (g)	Moving parts "0" stroke (g)	Increase per mm stroke (g)
40	399	3,9	162	1,75
50	591	5,07	265	2,37
63	939	6,34	417	2,75

RT230...M

Cyl. Ø	Cylinder "0" stroke (g)	Increase per mm stroke (g)	Moving parts "0" stroke (g)	Increase per mm stroke (g)
40	374	3,9	191	2
50	553	5,07	306,5	2,62
63	871	6,34	459	3

RT230...I

Cyl. Ø	Cylinder "0" stroke (g)	Increase per mm stroke (g)	Moving parts "0" stroke (g)	Increase per mm stroke (g)
40	374	3,9	137	1,75
50	552	5,07	225,5	2,37
63	871	6,34	349	2,75

RT233...

Cyl. Ø	Cylinder "0" stroke (g)	Increase per mm stroke (g)	Moving parts "0" stroke (g)	Increase per mm stroke (g)
40	405	3,9	168	1,75
50	583	5,07	256,5	2,37
63	902	6,34	380	2,75