



Accessories Ball joints / Nipple

Ball joints

For swivel mounting, Lechler ball joints can be used with low-noise flat jet and round jet nozzles. 30° swivel range in all directions. No wearing seals, long-term problemfree operation, even with frequent adjustment.

$P_{max} = 25 \text{ bar}$

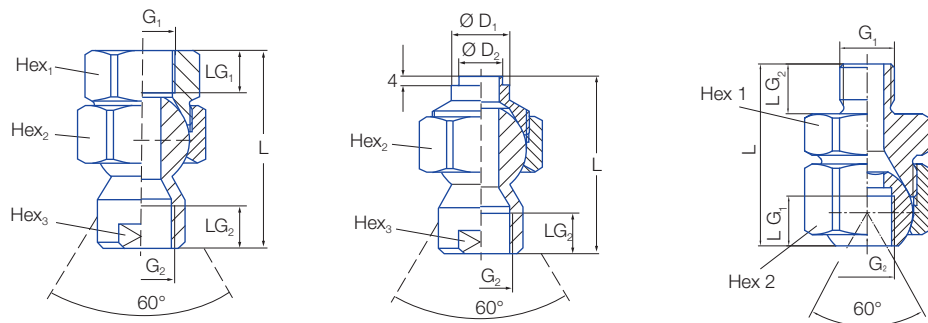

Connection	Ordering no.					Dimensions										Weight (Brass)
	Type	Mat. no.			Code	D ₁	D ₂	G ₁ ISO 228	G ₂ ISO 228	L _{G1} [mm]	L _{G2} [mm]	L [mm]	SW ₁	SW ₂	SW ₃	
		16 AISI 303/ AISI 316Ti	16 AISI 303	30 Brass												
Ball joints with thread connection	092.020	-	○	○	AD	-	-	1/4	1/4	12.0	11.5	60.3	27	27	17	60 g
	092.021	-	○	○	AF	-	-	3/8	1/4	12.0	11.5	58.3	27	27	17	80 g
	092.024	-	○	○	AC	-	-	1/4	1/4	12.0	12.0	44.0	27	27	-	140 g
	092.030	-	○	○	AF	-	-	3/8	3/8	12.0	12.0	44.0	27	30	-	160 g
Ball joints with welding connection	092.020	○	-	-	SD	20.0	15.0	-	1/4	-	11.5	64.3	-	27	17	60 g
	092.030	○	-	-	SF	22.0	15.0	-	3/8	-	12.0	58.7	-	30	19	80 g

Example of ordering: Type + Mat. no. + Code = Ordering no.
092.020 + 16 + AD = 092.020.16.AD

Nipple

095.016.30.14.23.0

The nipple made of brass allows for connection of nozzles with compressed air guns. Suitable for the series:

- 600.130
- 600.283
- 600.332
- 600.606
- 600.493
- 600.484
- 600.326
- 544

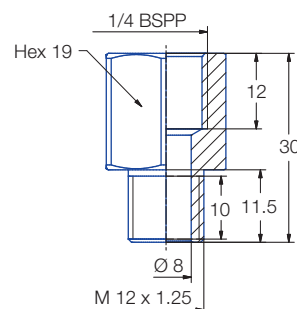



Accessories

Eyelet clamps / Double nipples / Nuts

Eyelet clamps

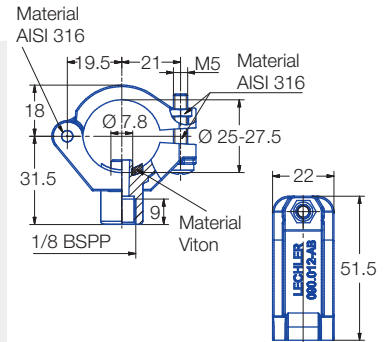
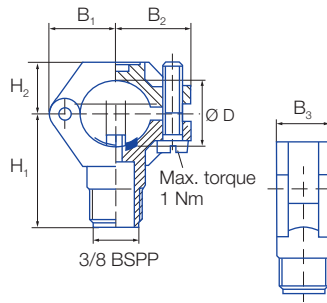

Ordering no.	Mat. no.			Screw	Dimensions [mm]								Weight (Polyamid)
	51	53	5E		Pipe Ø	D Ø	B _R Ø	B ₁	B ₂	B ₃	H ₁	H ₂	
Type	Polyamid	Polypropylene	PVDF										
090.053	○	○	○	Material AISI 316Ti	3.8"	16.5-18.0	6.2	19.0	22.0	18.5	34.5	14.5	20 g
090.003	○	○	○		1/2"	20 - 22.0	6.2	21.2	23.8	18.5	36.5	16.5	20 g
090.013	○	○	○		3/4"	25 - 27.5	7.8	24.5	26.5	22.0	39.5	17.5	25 g
090.023	○	○	○		1"	32 - 34.5	10.8	30.0	31.0	22.0	44.0	21.0	32 g
090.033	○	○	○		1 1/4"	40 - 43.0	12.8	34.0	35.5	25.0	48.0	25.0	38 g
090.012	-	-	○	AISI 316	3/4"	25 - 27.5	7.8	19.5	21.0	22.0	31.5	18.0	40 g

Double nipples

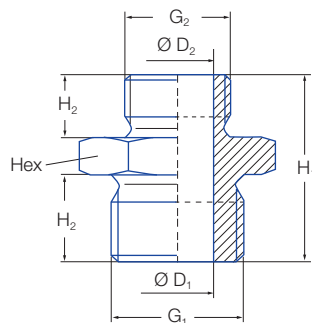

Ordering no.	Mat. no.		Dimensions [mm]								Weight (Brass)
	17	30	G ₁ BSPP	G ₂ BSPP	H ₁	H ₂	D ₁	D ₂	Hex		
Type	AISI 316Ti	Brass									
065.215	○	○	3/8	1/4	25	10	10	7	22	30 g	
065.211	○	○	3/8	3/8	25	10	11.5	-	22	25 g	

Nuts

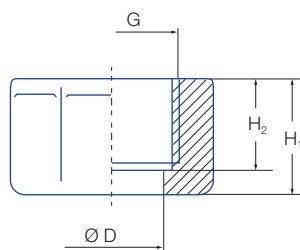

Ordering no.	Mat. no.					Dimensions [mm]					Weight (Brass)
	16	17	30	56	5E	G BSPP	H ₁	H ₂	D	Hex	
Type	AISI 303	AISI 316Ti	Brass	POM	PVDF						
065.200	○	○	○	-	-	3/8	13.0	10.0	12.8	22	25 g
065.200	-	-	-	○	○	3/8	14.5	11.5	12.8	22	25 g