



U

CENTRIFUGAL PUMPS WITH
SINGLE MECHANICAL SEAL



U

Centrifugal pumps with single mechanical seal

Housing and impeller material:	PVDF
Elastomers:	EPDM, FKM (e.g. Viton®), FEP, FFKM (e.g. Kalrez®)
Mechanical seal materials:	SiC (silicon carbide), graphite carbon, PTFE-GF, Al ₂ O ₃ -ceramics
Metal parts:	Stainless steel ANSI 316Ti (1.4571), Hastelloy® C4

The U series is the SCHMITT entry model to cope with corrosive media. The impeller is directly mounted on the motor shaft extension. The pump is sealed with a single mechanical seal that is cooled and lubricated by the fluid. The mechanical seal is available in different versions, featuring various elastomer and seal face materials and an optional PVDF shaft sleeve.

PERFORMANCE CHART

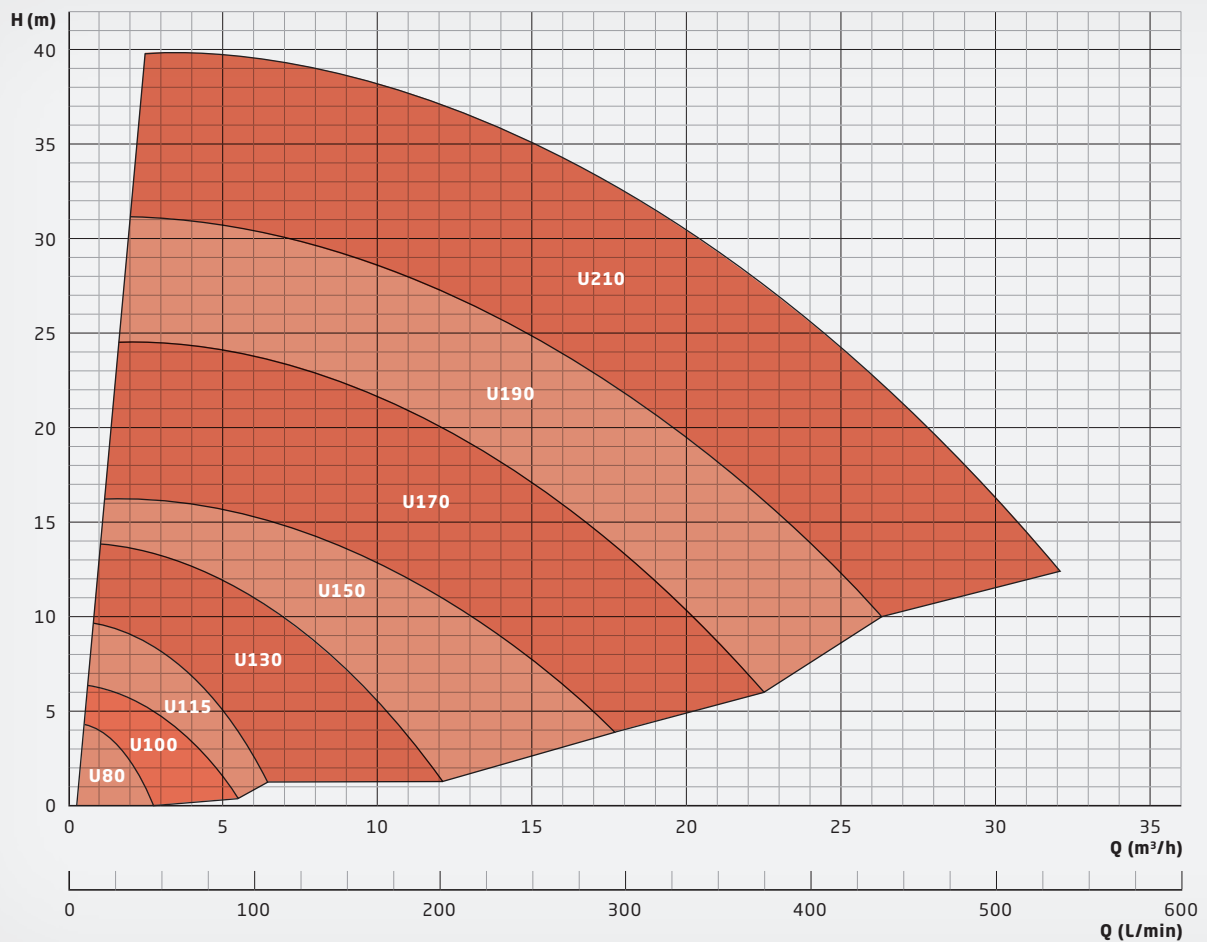

Advantages:

- + Economic and robust alternative to magnetic drive pumps
- + Pumping of magnetic particles possible
- + Compact close-coupled design
- + Suited for corrosive media

Different versions and materials available allow for a perfect match to many operating conditions. Solid particles up to 3 mm in size and 10% volume are allowed. The maximum viscosity is 150 mPas, the maximum allowed temperature is 95°C. All sizes are also available in ATEX-certified versions under the name U-EX for ATEX zone 2.

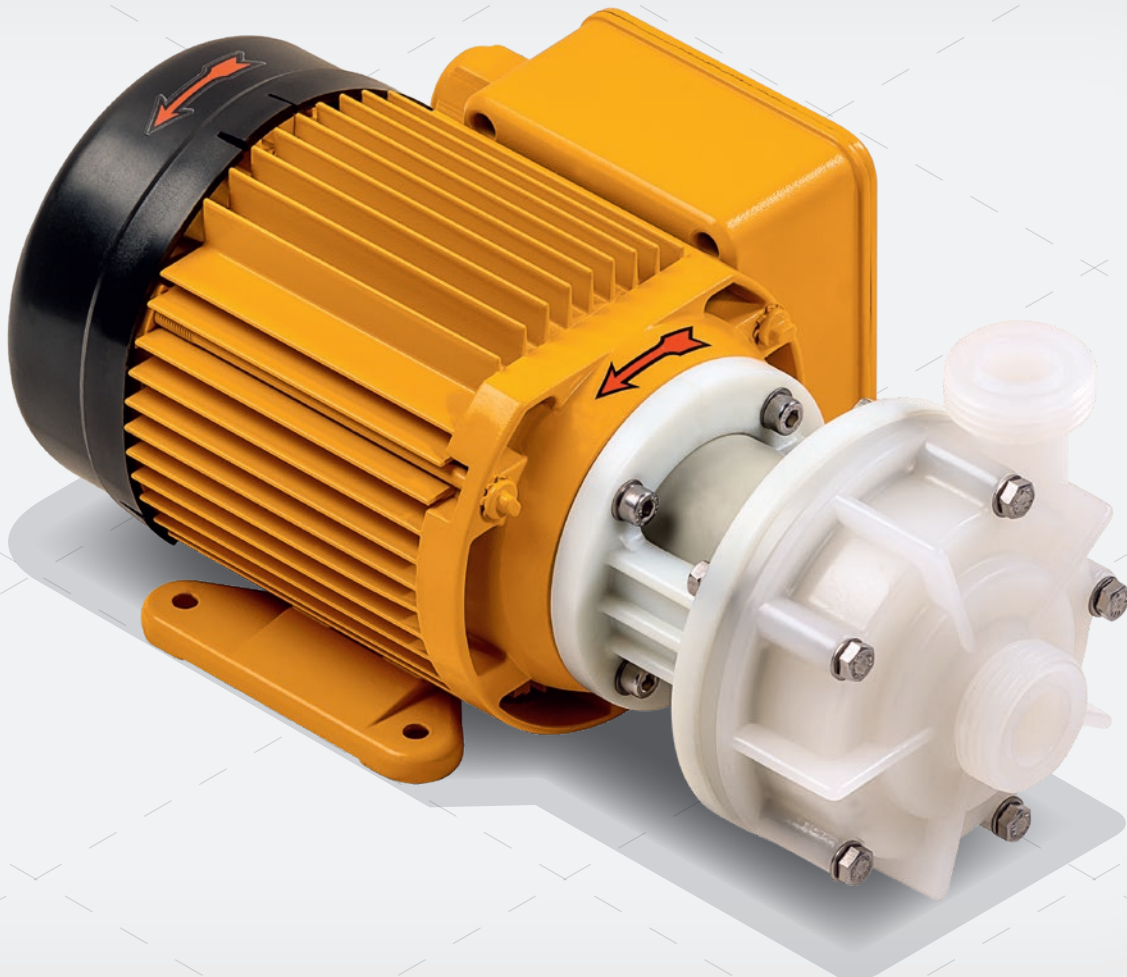



U

Centrifugal pumps with single mechanical seal

DESCRIPTION

Characteristics	Non-metallic, chemical-resistant, single-stage centrifugal pump, with single mechanical seal
Features	<ul style="list-style-type: none">· Economic and robust alternative to magnetic drive pumps· Well-suited for solid-containing fluids due to spring-loaded mechanical seal· Pumping of magnetic particles possible· Low-maintenance-operation due to high-quality seal face materials· All wet parts made of high-quality, corrosion-resistant materials· Threaded connections (ISO 228-1) as standard· Available with flange connections from size 130· Universally applicable, low-noise and compact close-coupled design
Fields of application	<p>Delivery of acids, bases or other corrosive liquids in such applications, where a hermetically sealed pump is not required. Delivery of acids and bases or other corrosive liquids containing low to medium amounts of solid particles.</p> <p>For example in the following applications:</p> <ul style="list-style-type: none">· Plating and surface coating· Semiconductor technology and solar cell production· PCB and electronics manufacturing· Wastewater and fresh water treatment· Laboratory equipment and medical technology· Emission controls and gas scrubbers· Battery production and energy storage· High-purity applications, demineralized water, ultrapure water

TYPES

Characteristics	<ul style="list-style-type: none"> · Pump housing: PVDF · Elastomers: FKM, EPDM, FEP, FFKM · Material of mechanical seal faces: PTFE/Al₂O₃, carbon/Al₂O₃, SiC/SiC, SiC/carbon
Standard motors (available from stock)	<ul style="list-style-type: none"> · Three-phase motors: D230/Y400 V-3ph @ 50 Hz, D277/Y480 V-3ph @ 60 Hz, IP 55, Ins.-Cl. F, also with PTC · All motors from 0.75 kW have energy efficiency class IE3 · Single-phase motors (up to 1.1 kW: 230 V-1ph, 50 / 60 Hz, IP 55, Ins.-Cl. F) · ATEX-certified motors (temperature rating T3)
Special motors (available on request, for example)	<ul style="list-style-type: none"> · Special voltages and frequencies · ATEX-certified motors (temperature rating T4 or T5) · Three-phase motors with integrated drive / frequency converter · Four-pole motors with 1450 rpm @ 50 Hz / 1650 rpm @ 60 Hz · UL- and CSA-certified motors · Special types of protection, e.g. IP 65 · Special insulation classes, e.g. tropical insulation · Multi-voltage, e.g. D220-290/Y380-500 V, 50 Hz; D220-332/Y380-575 V, 60 Hz · Direct-current motors (DC or BLDC)
Operating conditions	<ul style="list-style-type: none"> · Flow rate up to: 30 m³/h · Maximum head up to 40 m · Liquid temperature: -5 to 95°C (PVDF) · Ambient temperature from -10 up to 40°C, higher temperatures on request · Pumps can be adapted to high-density liquids (up to 2)



U

Centrifugal pumps with single mechanical seal

PERFORMANCE CURVE **U 80** (0.18 kW) / **U 101** (0.18 kW)

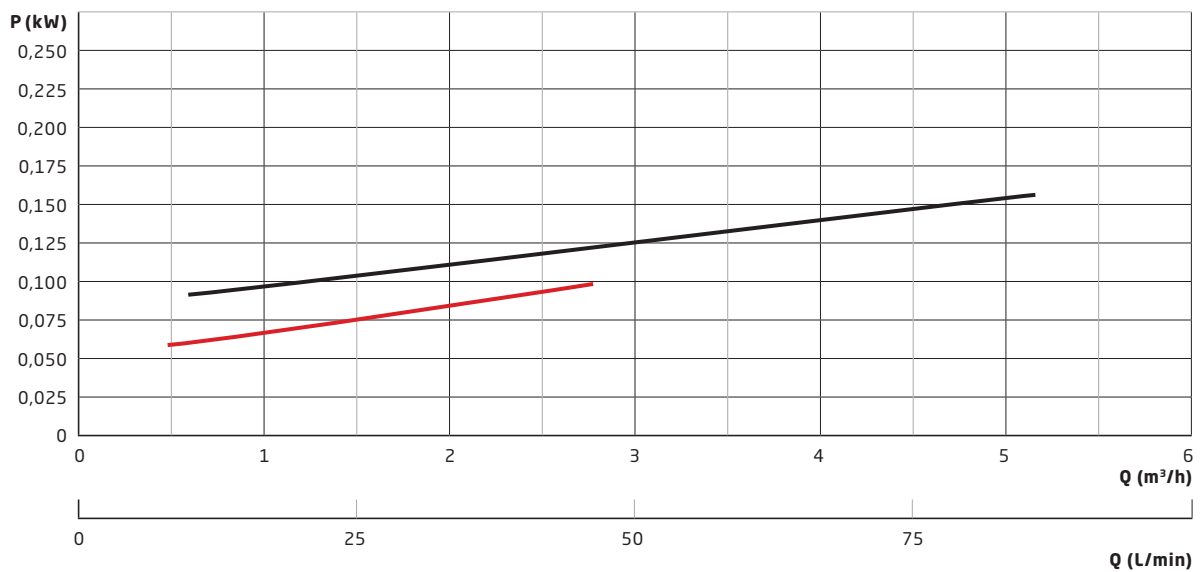

PERFORMANCE CURVE **U 115** (0.25 kW) / **U 130** (0.55 kW)

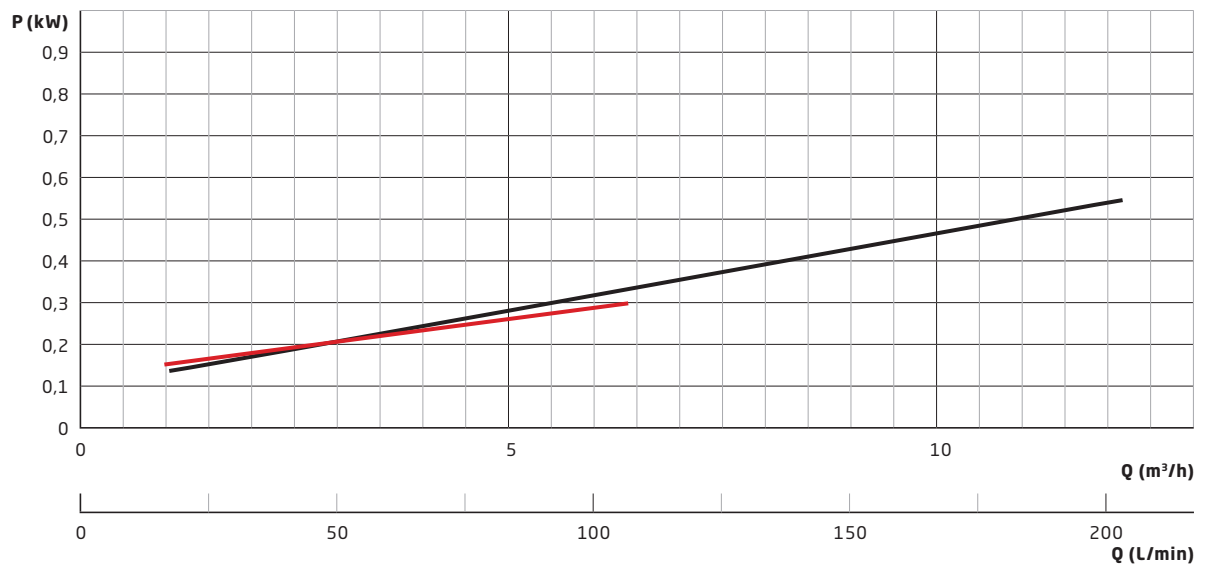
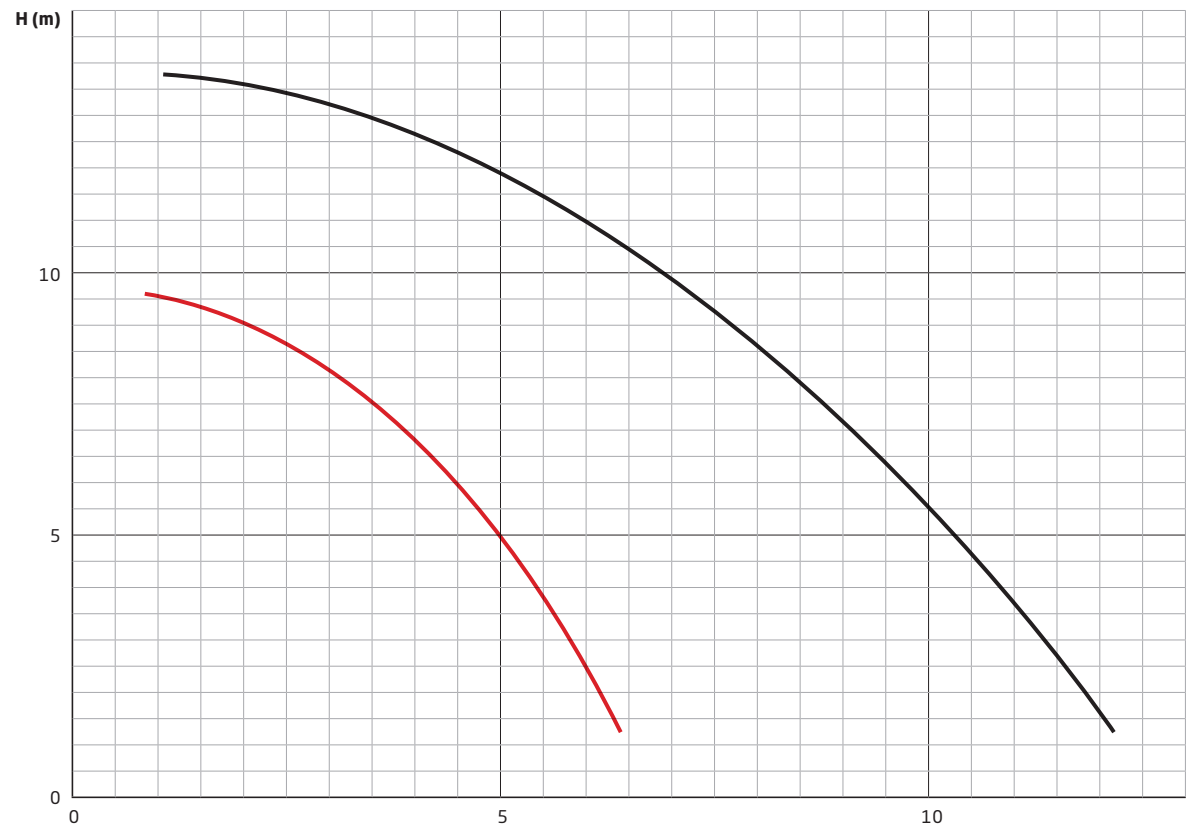



U

Centrifugal pumps with single mechanical seal

PERFORMANCE CURVE **U 150** (1.1 kW) / **U 170** (2.2 kW)

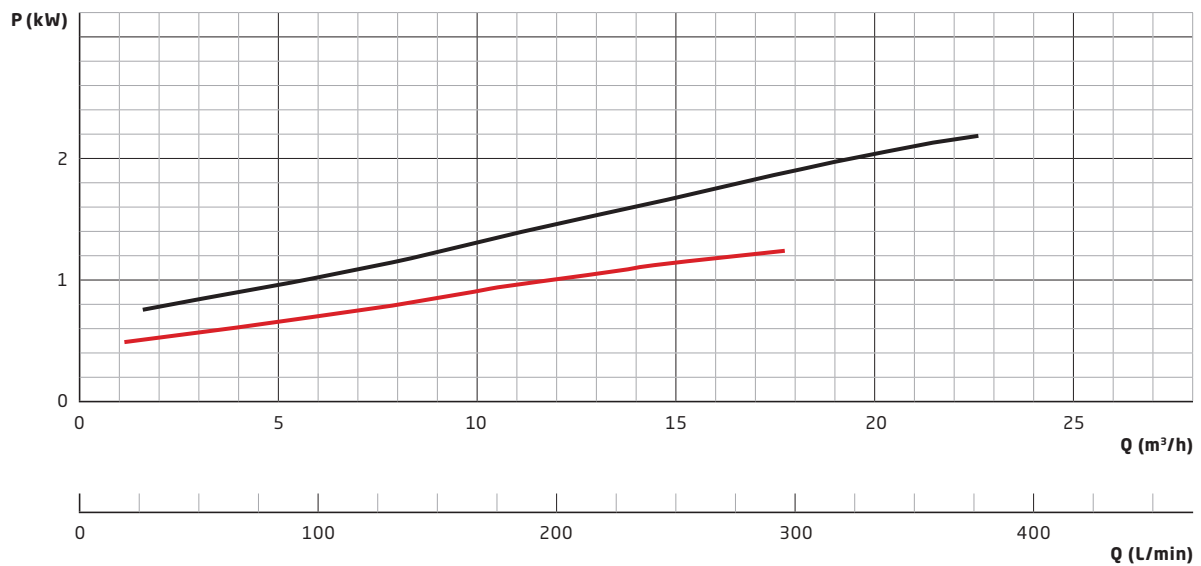
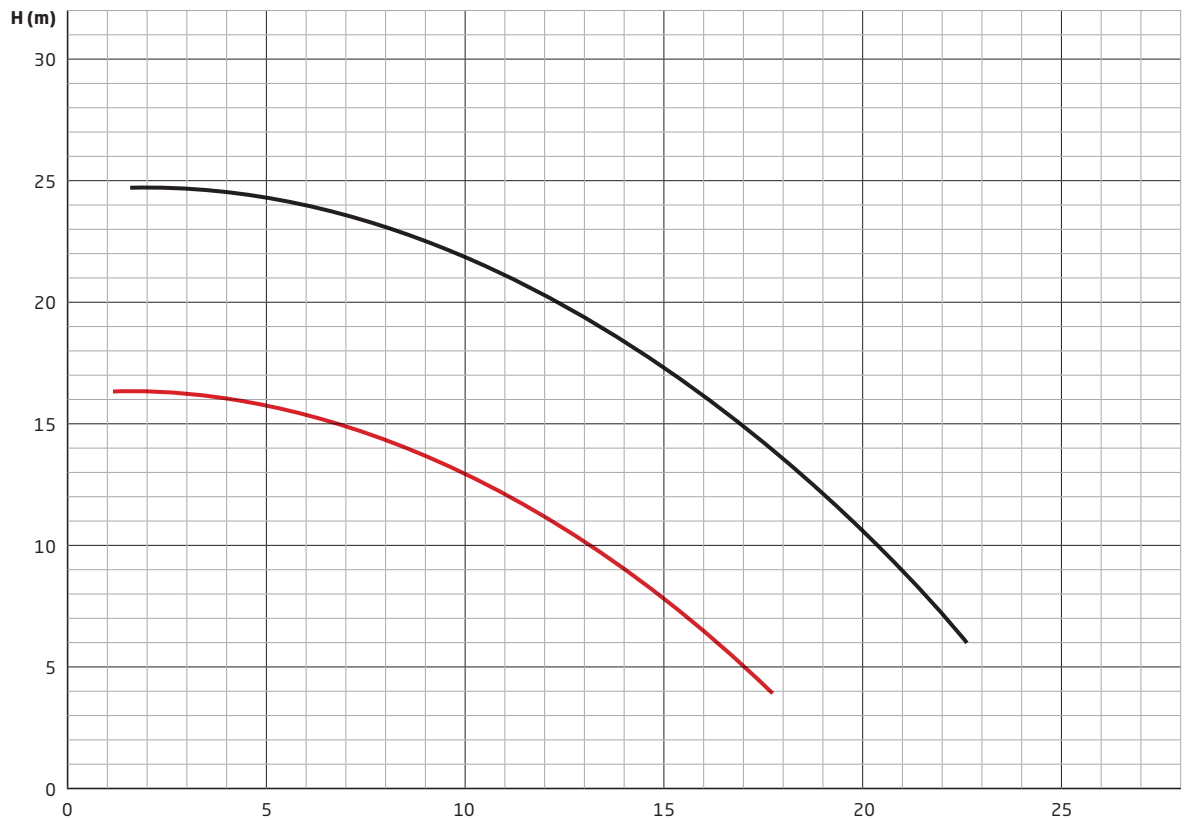

PERFORMANCE CURVE **U 190** (3 kW) / **U 210** (5.5 kW)

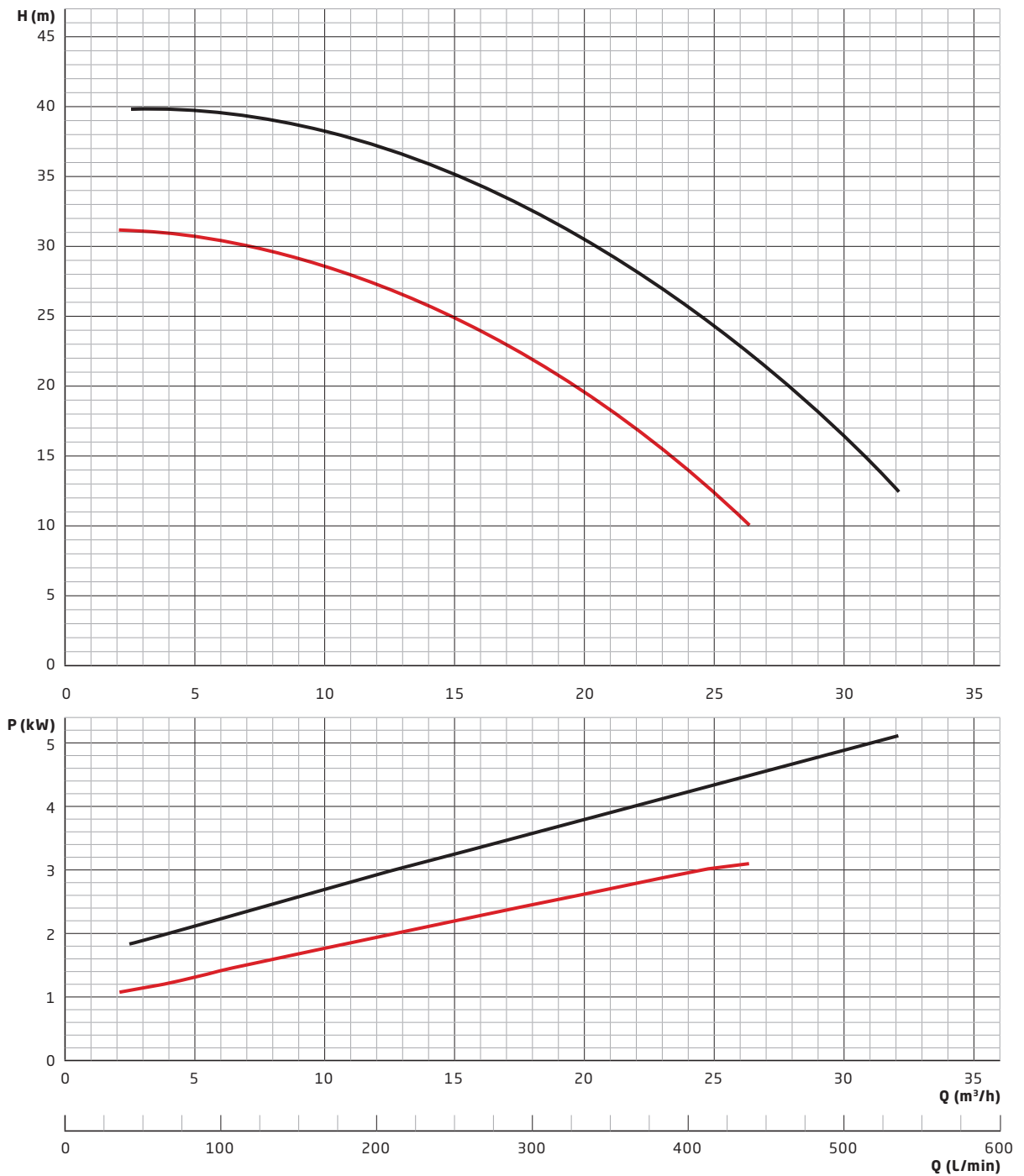



U

Centrifugal pumps with single mechanical seal

DIMENSIONS

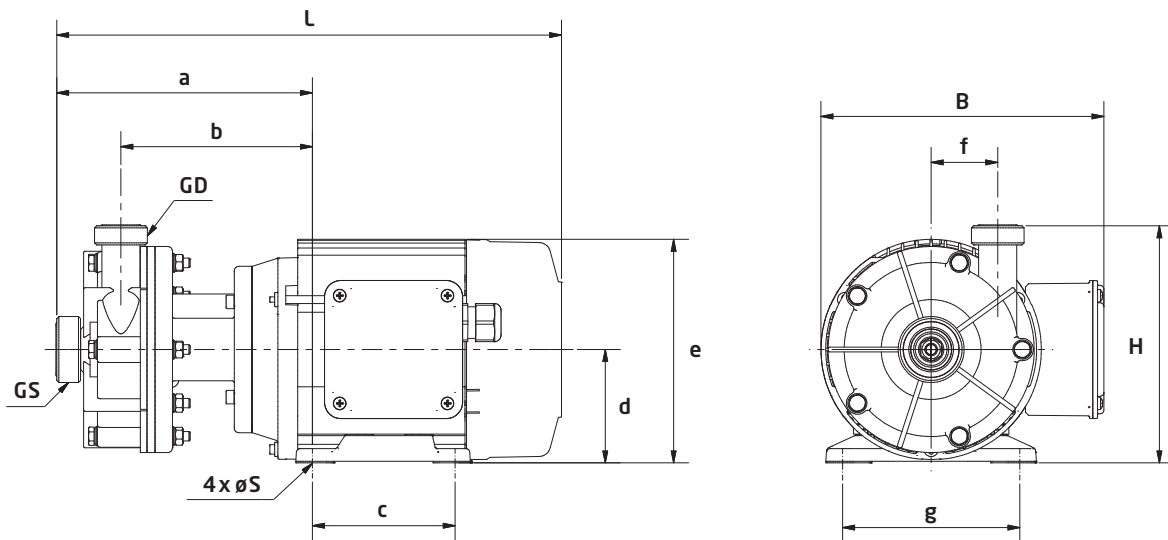

Type	GS		GD		L (mm)	B (mm)	H (mm)	S (mm)	a (mm)	b (mm)	c (mm)	d (mm)	e (mm)	f (mm)	g (mm)
	Thread	DN	Thread	DN											
80	G¾"	10	G¾"	10	282	152	108	6	142	107	71	56	113	25	90
101	G1"	15	G1"	15	283	152	118	6	144	108.5	71	56	113	31	90
115	G1"	15	G1"	15	329	165	134	7	159	122	80	63	126	37	100
130	G1¼"	20	G1"	15	343.5	183	149	7	161	121	90	71	141	42	112
150	G1½"	25	G1¼"	20	411	209	171	10	200	152	100	80	159	47	125
170	G2"	32	G1½"	25	466.5	230	190	10	231	176	125	90	178	58	140
190	G2"	32	G1½"	25	496	256	211	12	242	182	140	100	198	65	160
210	G2¼"	40	G2"	32	505	278	236	12	242	193	140	112	221	74	190

FITTINGS

SCHMITT offers an extensive range of fittings to facilitate the installation of the pump into your system:

- flange adaptors
- hose connectors
- welding connectors for stainless steel pipes
- reducers
- NPT threaded adaptors
- inlet strainers for vertical pumps
- extension pipes for vertical pumps

SPARE PARTS LIST

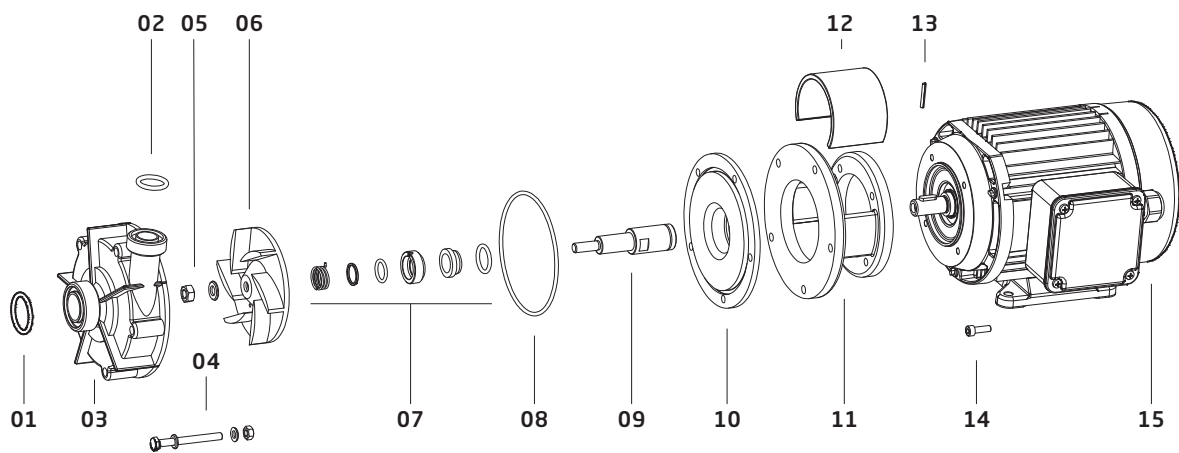

Position	Description	Available materials
01	O-ring (inlet port)	FKM, EPDM, FEP, FFKM
02	O-ring (outlet port)	FKM, EPDM, FEP, FFKM
03	Pump housing	PVDF
04	Hexagon bolt, washer, nut	V4A
05	Locking nut, washer	V4A, Hastelloy C4
06	Impeller	PVDF
07	Mechanical seal	Various options
08	Housing seal	FKM, EPDM, FFKM
09	Shaft	Stainless steel 1.4571 / 316Ti, Hastelloy C4
10	Backplate	PVDF
11	Flange	PP, aluminium
12	Protection cover	PP
13	Slotted pin	V4A
14	Cylinder bolt	V4A
15	Motor	



SCHMITT-Kreiselpumpen GmbH & Co. KG

Einsteinstraße 33

76275 Ettlingen, Germany

Fax: +49 7243 5453-22

E-mail: sales@schmitt-pumpen.de

Direct line:

Telephone: +49 7243 5453-0

www.schmitt-pumpen.de

We reserve the right to make changes to the technical information contained in this brochure without prior notice.
All data is without obligation and non-binding.

Last update: 09 / 2022