

NEOLUTION NHM

NORMAL-PRIMING CENTRIFUGAL PUMPS MADE OF
PVDF OR PP WITH MAGNETIC COUPLING

SCHMITT NEOLUTION®
IS THE

NEW BENCH- MARK

FOR CHEMICAL
RESISTANT
CENTRIFUGAL PUMPS.
FOR FOUR REASONS.



Incredible 76% efficiency

We have incorporated all our expertise into the development of the NEOLUTION NHM. And we're proud that it has set a new efficiency benchmark. Not only for us, but also for the entire industry.



Maximum energy efficiency to protect the climate

Reducing CO₂ emissions and saving energy are the order of the day. And because the NEOLUTION NHM requires up to 50% less energy than pumps in the previous generation, depending on the operating point, it delivers a sustainable contribution. That's another plus for the NEOLUTION NHM.



Maintenance-free and durable

One reason for the NEOLUTION NHM's impressive performance is its new bearing technology. Its extra-large, decoupled radial-axial slide bearings made of wear-resistant materials allow it to operate without requiring maintenance. And it's extremely durable as a result.



Superior resistance

When we developed the NEOLUTION NHM, it was basic requirement that it should be just as resistant to chemicals as all our other pumps. After all, as anyone who knows us can confirm: we have the right pump for every liquid.

WE LOVE ...

FINDING THE BEST SOLUTION FOR YOU

Why isn't it enough for us to produce first-class pumps? Because we're not satisfied until they're perfectly integrated into your operational processes and therefore working even more efficiently. And we want our partners in the specialist trade to benefit from this optimal performance too.

PUTTING OUR HEADS TOGETHER FOR YOU

Why do we always put our heart and soul into our work? Because that's how you get the best from us every time: top quality, perfectly tailored concepts, and impressive service.

MAKING THINGS POSSIBLE

Why isn't the word "impossible" in our vocabulary? Because we're happy to come to your rescue. And because your success is always our top priority.

...
HELPING TO MAKE
SURE EVERYTHING
RUNS SMOOTHLY
FOR YOU

PRODUCT FEATURES

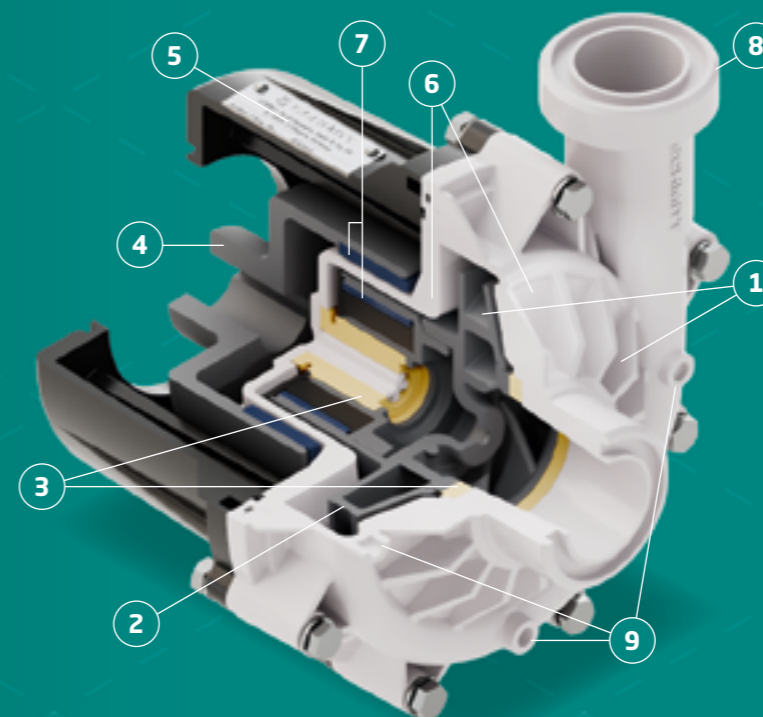

1
**OPTIMISED PUMP
HYDRAULICS**
for best-in-class efficiencies of up to 76%

2
MODULAR IMPELLER
for easy replacement and cost-effective repairs

3
**SPECIAL SLIDE BEARING
SOLUTION MADE OF HIGH-
PERFORMANCE MATERIALS**
Durable and maintenance-free even in extreme operating conditions

4
**ENCLOSURE MADE OF
CHEMICALLY RESISTANT,
CARBON-FIBRE-REINFORCED
PLASTIC**
High strength and zero corrosion even in aggressive environmental conditions

5
**CHEMICALLY RESISTANT
TYPE PLATE**
for reliable identification even after years in a harsh operating environment

6
**COMPUTER-OPTIMISED
HOUSING**
for reliable operation at high pressures and temperatures

7
**HIGH-PERFORMANCE
NEODYMIUM MAGNETS**
for safe power transmission even in media with very high densities

8
**AVAILABLE WITH
THREADED OR FLANGE
CONNECTIONS**

9
**OPTIONAL DRAINAGE OR
VENTILATION HOLES**
for individual installation positions



NEOLUTION NHM

Normal-priming centrifugal pumps made of PVDF or PP with magnetic coupling



- Housing and impeller materials:** PVDF, PP
Elastomers: EPDM, FKM (e.g. Viton®), FEP, FFKM (e.g. Kalrez®)
Slide bearing materials: SiC/SiC (silicon carbide) or carbon/SiC

The all-new NEOLUTION pump boasts an efficiency level of up to 76%, setting new energy efficiency standards in this class. Made from a selection of chemical-resistant, high-performance materials matched to individual requirements, the NEOLUTION delivers maximum performance coupled with superior durability. The NEOLUTION is a groundbreaking new design, developed without compromise and with your needs in mind.

Advantages:

- + Best-in-class efficiency, extremely energy-efficient.
- + Wear- and maintenance-free and durable thanks to its unique bearing featuring slide axis technology
- + Hermetically sealed & contactless magnetic drive, absolutely leak-free

All sizes are also available in ATEX-certified versions for use in ATEX zones 1 and 2. Available with threaded and flanged connections as well as with drain and ventilation holes.

NHM 200 PERFORMANCE CHART

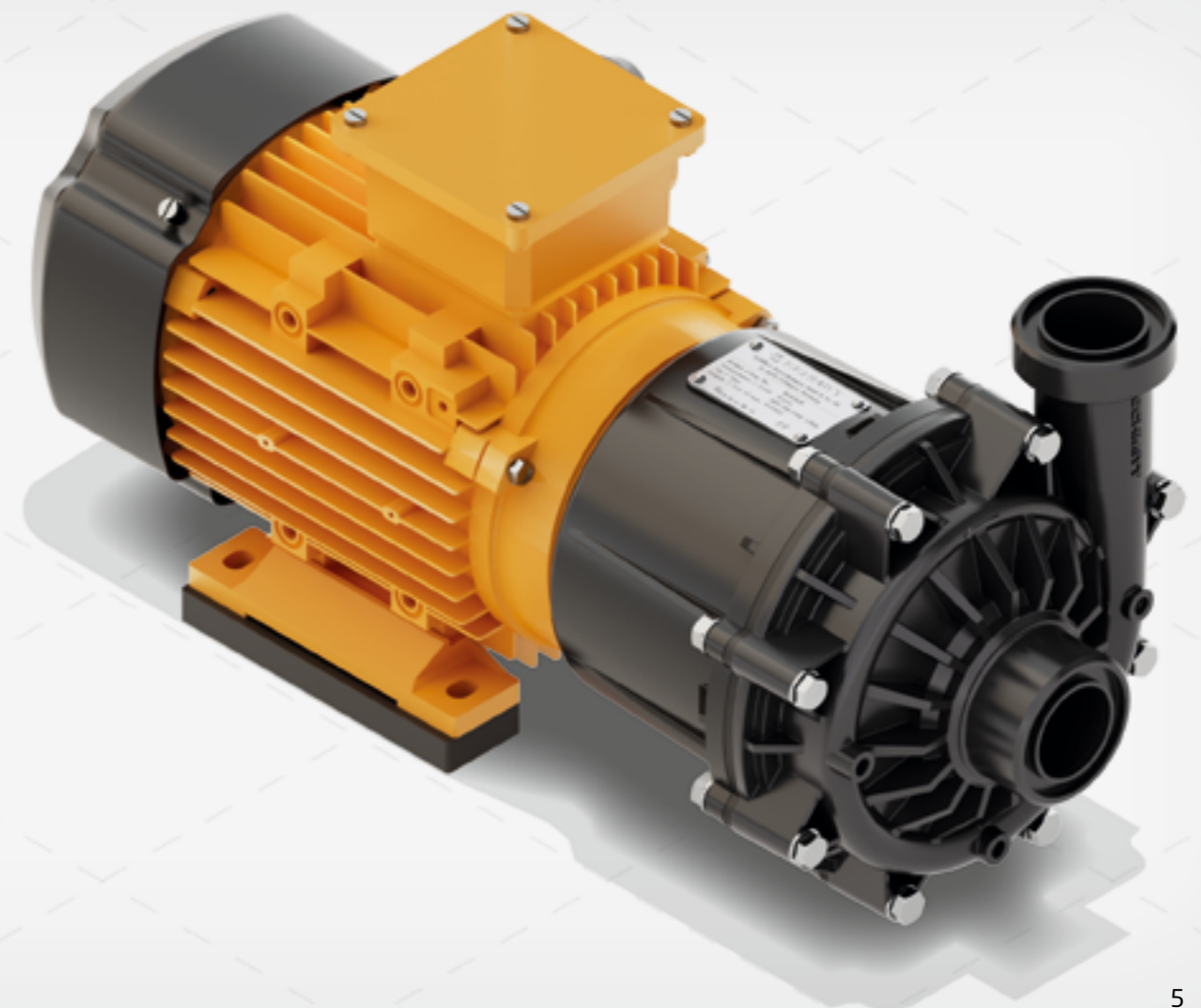
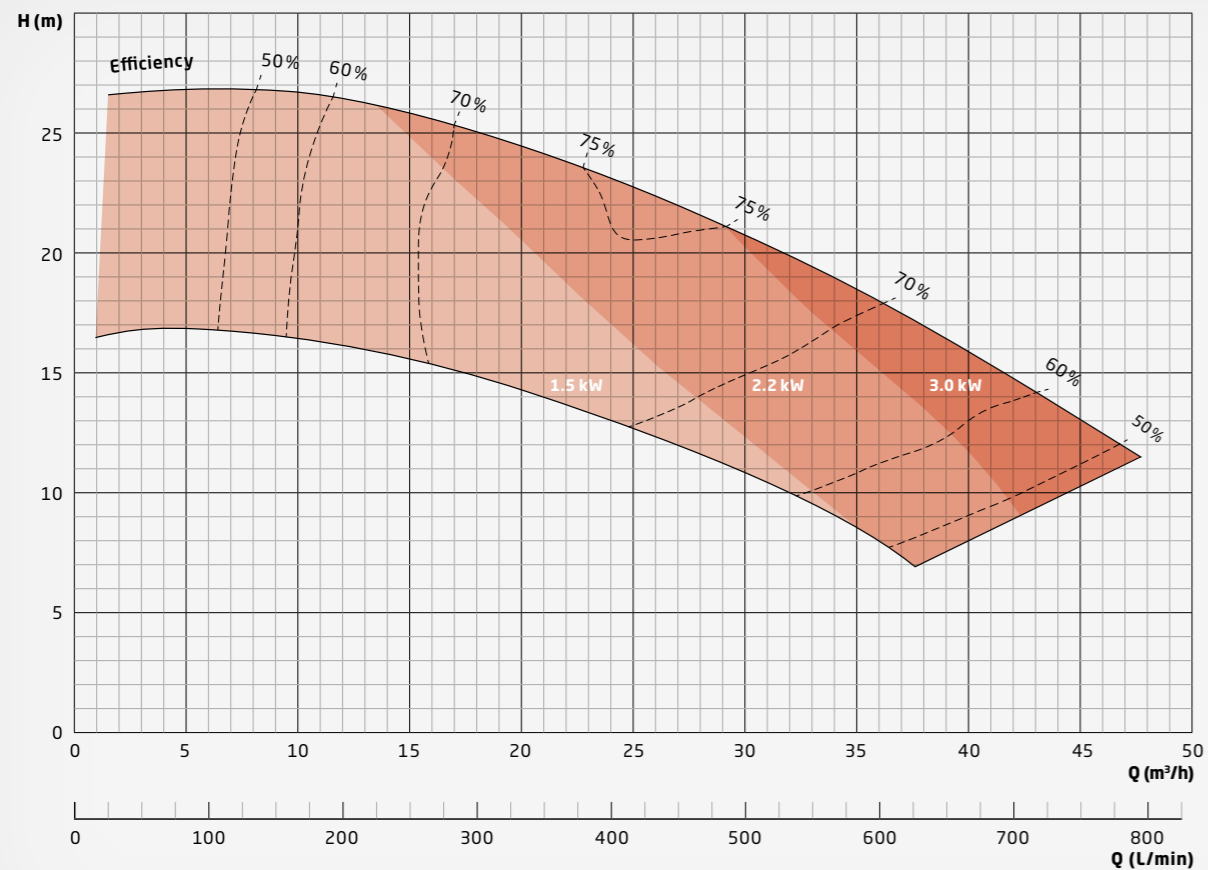



NEOLUTION NHM

Normal-priming centrifugal pumps made of PVDF or PP with magnetic coupling



DESCRIPTION

Characteristics	Chemical-resistant, single-stage plastic centrifugal pump with close-coupled design, with magnetic coupling, normal-priming
Features	<ul style="list-style-type: none"> · Hermetically sealed and absolutely leak-free (no mechanical seal) · Contactless magnetic drive with high-performance neodymium magnets · Highly efficient impeller and optimised volute casing for efficiencies of up to 76% · Modular impeller and internal magnet for easy replacement · Maintenance-free in normal operation due to extra-large slide bearings · Reliable operation even at high pressures and temperatures thanks to unique backplate geometry · All wet parts made of high-quality, corrosion-resistant plastics (natural PVDF or PP-CF and natural PP) · Equipped as standard with threaded connections in accordance with ISO 228-1 or flange connections · Universally applicable, low-noise, and compact · Optional approval for use in potentially explosive atmospheres (ATEX Zones 1 and 2) · Conductive plastic parts available for ATEX Zone 1 (on request) · All screws made of V4A stainless steel (1.4571) · Optional ventilation or drainage holes for individual installation positions
Fields of application	<p>Delivery of acids, bases, lye, or other corrosive, harmful, or toxic liquids in applications where leakage of even small quantities is undesirable and a hermetically sealed pump is required.</p> <p>Delivery of highly pure and sensitive liquids where contamination must absolutely be avoided.</p> <p>For example in the following applications:</p> <ul style="list-style-type: none"> · Electroplating and surface coating · Wet chemical processes in semiconductor technology, solar cell production, and PCB manufacturing · Wastewater and fresh water treatment · Laboratory equipment and medical technology · Environmental technology, emission control, gas scrubbers · Battery production and energy storage · High-purity applications, demineralised water, ultrapure water

CHARACTERISTICS

Materials	<ul style="list-style-type: none"> · Pump housing: PVDF, PP · Elastomers: FKM, EPDM, FEP, FFKM · Slide bearing materials: SiC/SiC (silicon carbide) or carbon/SiC
Standard motors (available from stock)	<ul style="list-style-type: none"> · Three-phase motors: D230/Y400 V-3ph @ 50 Hz, D277/Y480 V-3ph @ 60 Hz, IP 55, ins. cl. F, also with PTC · All three-phase motors from 0.75 kW are in energy efficiency class IE3 · Single-phase motors (up to 1.1 kW: 230 V-1ph, 50/60 Hz, IP 55, ins. cl. F) · ATEX-certified motors (temperature rating T3)
Special motors (available on request)	<ul style="list-style-type: none"> · Special voltages and frequencies · Three-phase motors with integrated frequency converter · ATEX-certified motors with flameproof enclosure and temperature rating T4 · Four-pole motors with 1450 rpm at 50 Hz · UL- and CSA-certified motors · Special types of protection, e.g. IP 65 · Special insulation classes, e.g. tropical insulation · Multi-voltage, e.g. D220-290/Y380-500 V, 50 Hz; D220-332/Y380-575 V, 60 Hz · Direct-current motors (DC or BLDC)
Operating conditions	<ul style="list-style-type: none"> · Flow rate up to 42 m³/h · Maximum head up to 27 m · Liquid temperature: -5°C to 95°C (PVDF); 0°C to 80°C (PP) · Ambient temperature: -10°C to 40°C, higher temperatures on request · Can be adapted to high-density liquids (up to 2.0)



NEOLUTION NHM

Normal-priming centrifugal pumps made of PVDF or PP with magnetic coupling



DIMENSIONS

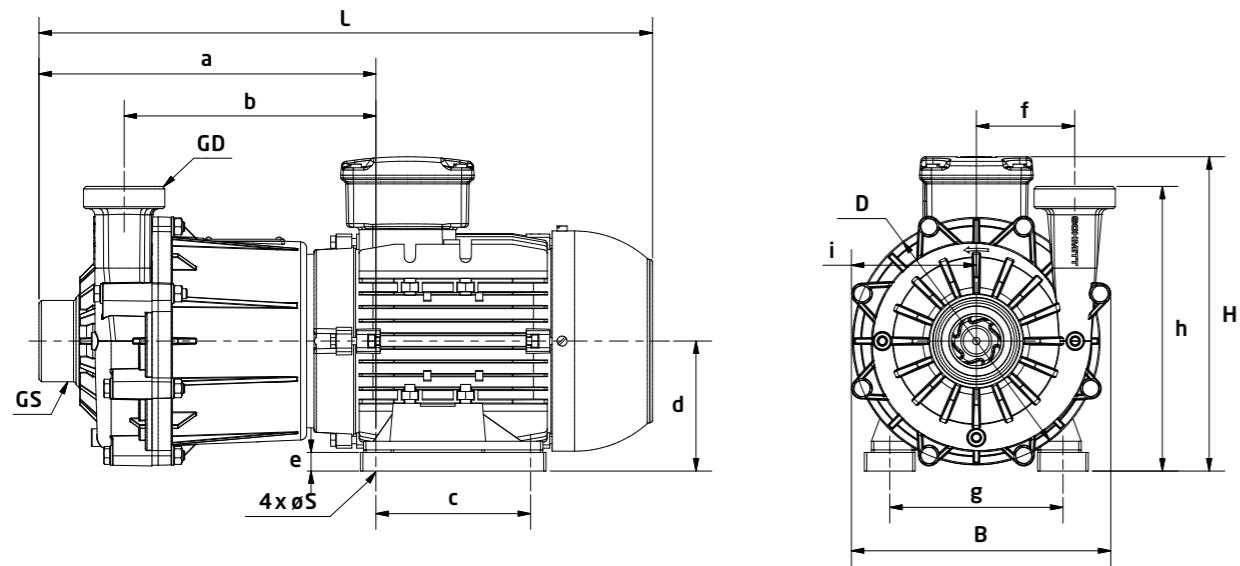

NHM200 model	GS		GD		L (mm)	B (mm)	H (mm)	S (mm)	a (mm)	b (mm)	c (mm)	D (mm)	d (mm)	e (mm)	f (mm)	g (mm)	h (mm)	i (mm)	Weight (kg)
	Thread (inches)	DN (mm)	Thread (inches)	DN (mm)															
1.5 kW	G2 1/4"	d50 40	G2 1/4"	d50 40	496	210	254	10	272	203	125	200	105	15	80	140	230	101	
2.2 kW	G2 1/4"	d50 40	G2 1/4"	d50 40	496	210	254	10	272	203	125	200	105	24	80	140	230	101	
3.0 kW	G2 1/4"	d50 40	G2 1/4"	d50 40	532	282	264	12	279	210,5	140	200	105	14	80	160	230	101	

FITTINGS

SCHMITT offers an extensive range of fittings to facilitate the installation of the pump into your system:

- Flange adaptors
- Hose connectors
- Welding connectors for stainless steel pipes
- Reducers and expanders
- NPT-threaded adaptors
- Inlet strainers for vertical pumps
- Extension pipes for vertical pumps

SPARE PARTS

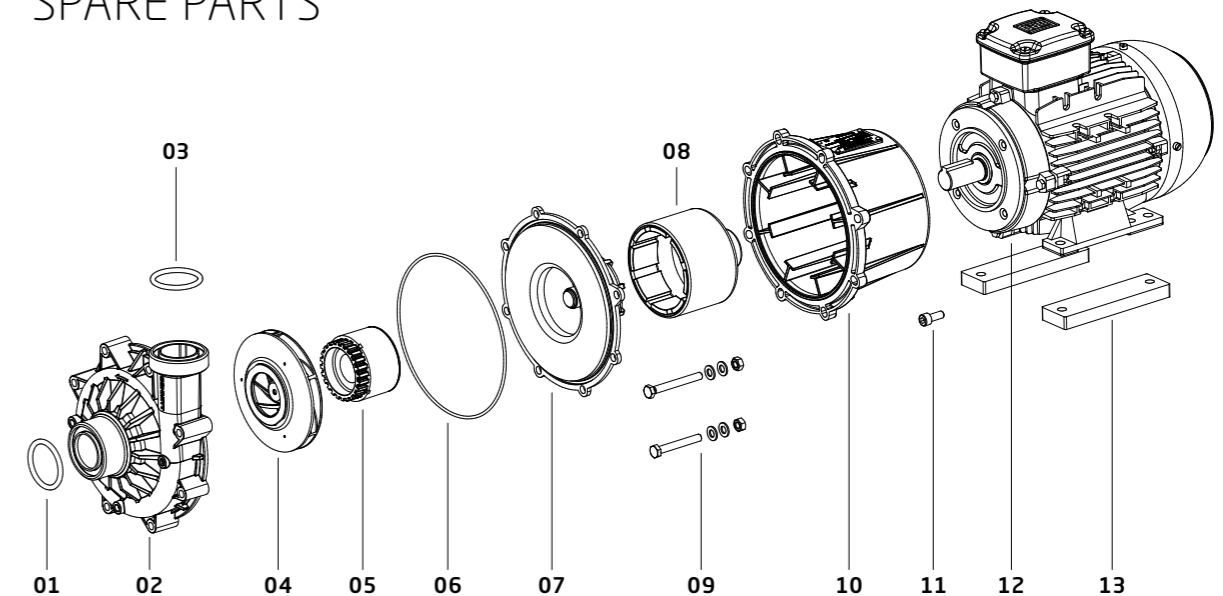

Position	Description	Available materials
01	O-ring (inlet port)	FKM, EPDM, FEP
02	Volute casing including bearing ring	Housing: PP-CF or PVDF Bearing ring: SiC
03	O-ring (outlet port)	FKM, EPDM, FEP
04	Impeller including bearing ring	Impeller: PP-CF or PVDF Bearing ring: SiC or carbon
05	Internal magnet including bearing sleeve	Internal magnet: PP, PVDF Bearing sleeve: SiC or carbon
06	O-ring (housing)	FKM, EPDM, FEP
07	Backplate including bearing bushing	Backplate: PP-CF or PVDF Bearing bushing: SiC
08	External magnet	
09	Screw set for housing	V4A
10	Enclosure	PP-CF
11	Screw set for enclosure	V4A
12	Motor	
13	Base plate	PP



NEOLUTION NHM

Normal-priming centrifugal pumps made of PVDF or PP with magnetic coupling

NHM200 CHARACTERISTIC LINES (1.5/2.2/3.0 kW)

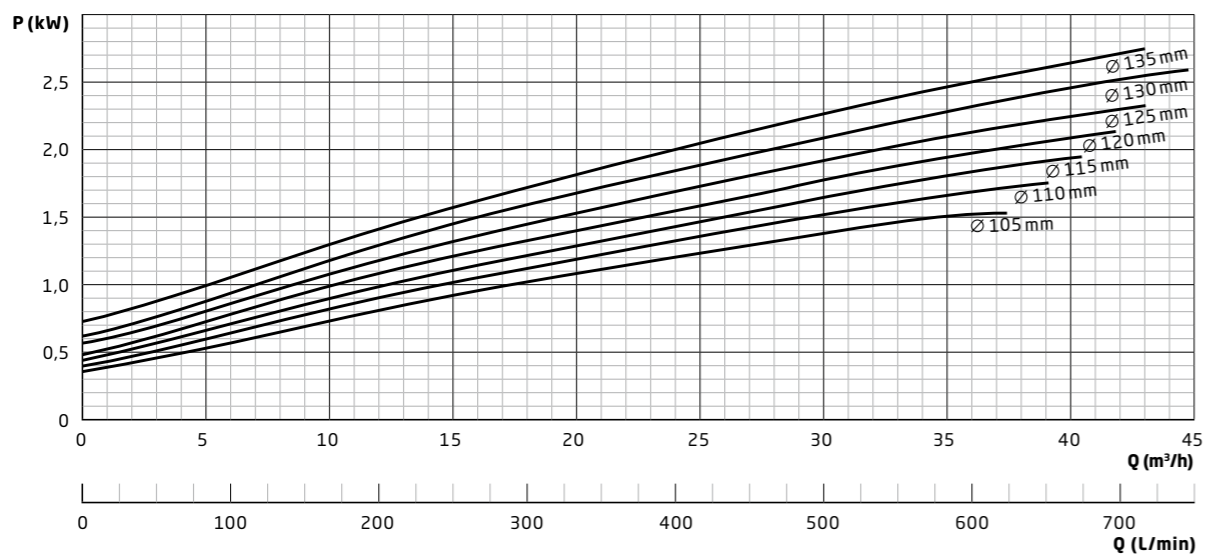
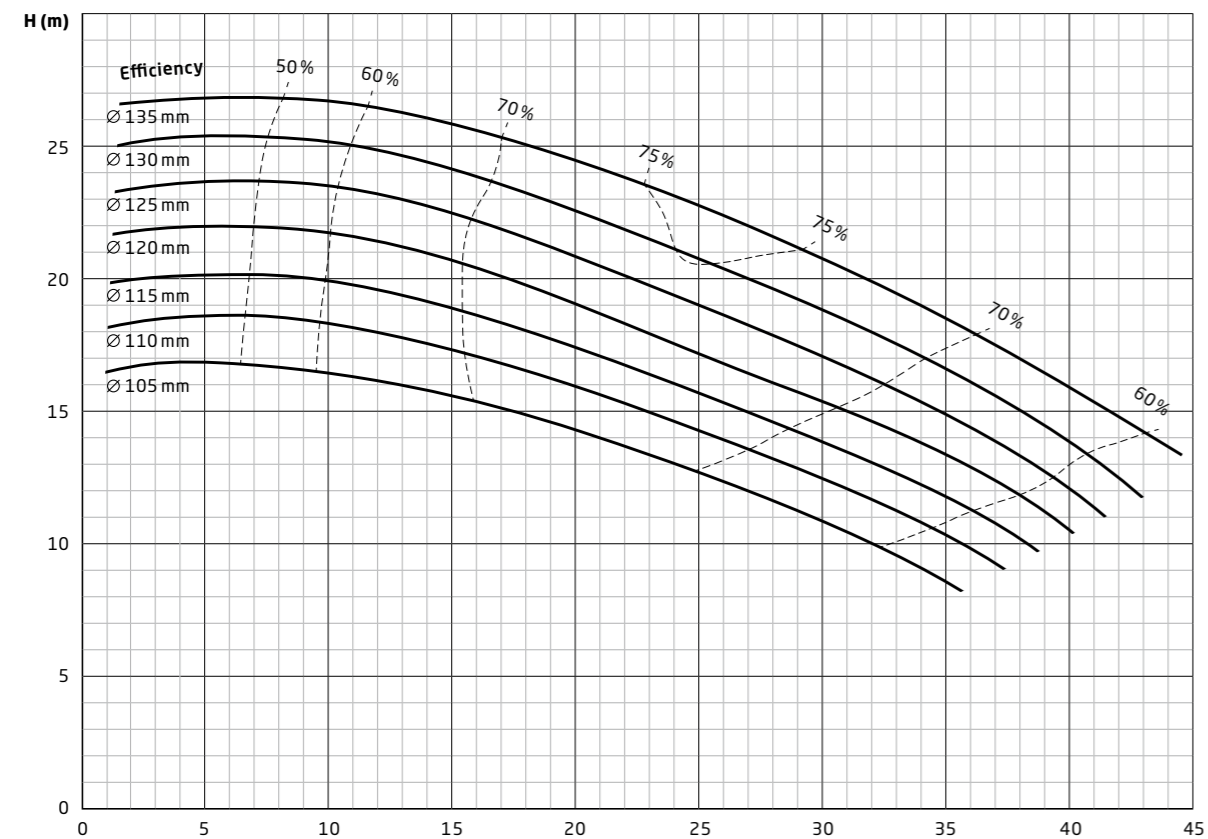

...
BEING YOUR
PERSONAL POINT OF
CONTACT:
+49 7243 5453-0



SCHMITT-Kreiselpumpen GmbH & Co. KG

Einsteinstraße 33

76275 Ettlingen, Germany

E-mail: sales@schmitt-pumpen.de

Direct line:

Telephone: +49 7243 5453-0

www.schmitt-pumpen.de

We reserve the right to make changes to the technical information contained in this brochure without prior notice.
All data is without obligation and non-binding.

Last update: 12/2022