

WILLBRANDT Rubber Compensator Type 57

Type 57 is a conical compensator produced by hand winding. Its overall length can not be varied. We have an extensive mould form package which is available on request. Due to its configuration, type 57 expansion compensation is only possible in the lateral and angular plane.

Design:

Conical bellow body with reinforcing inserts and integral rubber profiles for mating with swivel flanges. The compensator is self-sealing, additional gaskets are not required.

Application:

Noise and vibration damper for use in delivery pipe lines, containers, building outlets and pumps, and wherever a connection bridging piece allowing smooth free flow is required owing to the composition of the medium.



Details for type 57

Bellow colour code	Core (inner)	Reinforcing material	Cover (outer)	Permissible operating data				Electrical resistance [Ohm cm]	Hardness shore A
				bar	°C	bar	°C		
red	EPDM	Nylon cord	EPDM	6	20	6	90	7×10^3	60
yellow	NBR	Nylon cord	CR	6	20	6	90	5×10^3	60
green	CSM	Nylon cord	CSM	6	20	6	80	4×10^{10}	65
white	NBR/white	Nylon cord	CR	6	20	6	80	5×10^3	65
lilac	FPM	Kevlar	CR	6	20	4	150		65

Burst pressure > 24 bar

Flanges:

Swivel flanges both sides (Design A) with integral rubber profile, no additional gaskets required (self-sealing).

The flanges are drilled according to DIN PN 10 as standard. Other specifications according to DIN, ASA, BS and special flanges are also available.

Flange Material:

Standard S 235 JRG2 (RSt 37-2), zinc plated and yellow passivated. Other materials available on request.

Tie bar/Restraints:

It is recommended that these compensator elements be installed with internal bracing. Due to the build up of pressure, elastic deformation occurs which can distend the conical bellow body. This causes the compensator to either compress or high tensile loads to be exerted on the connecting parts.

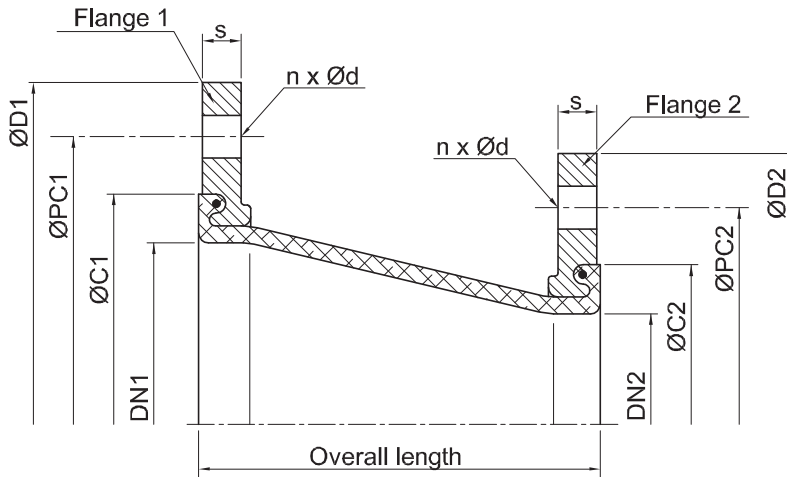

DN ₁	DN ₂	Overall length mm	ØC1 mm	Flange ₁			ØC2 mm	Flange ₂			s mm	Perm. pressure bar	lat ± mm
				ØD1 mm	ØPC1 mm	n x Ød		ØD2 mm	ØPC2 mm	n x Ød			
40	25	250	78	150	110	4 x 18	63	115	85	4 x 18	15	6	30
40	32	250	78	150	110	4 x 18	78	140	100	4 x 18	15	6	30
50	32	250	88	165	125	4 x 18	78	140	100	4 x 18	15	6	30
50	40	250	88	165	125	4 x 18	78	150	110	4 x 18	15	6	30
65	40	250	104	185	145	4 x 18	78	150	110	4 x 18	15	6	30
65	50	250	104	185	145	4 x 18	88	165	125	4 x 18	15	6	30
80	50	250	119	200	160	8 x 18	88	165	125	4 x 18	15	6	30
80	65	250	119	200	160	8 x 18	104	185	145	4 x 18	15	6	30
100	65	250	142	220	180	8 x 18	104	185	145	4 x 18	15	6	30
100	80	250	142	220	180	8 x 18	119	200	160	8 x 18	15	6	30
125	80	250	169	250	210	8 x 18	119	200	160	8 x 18	15	6	30
125	100	250	169	250	210	8 x 18	142	220	180	8 x 18	15	6	30
150	100	250	195	285	240	8 x 22	142	220	180	8 x 18	20	6	30
150	125	250	195	285	240	8 x 22	169	250	210	8 x 18	20	6	30
200	125	300	245	340	295	8 x 22	169	250	210	8 x 18	20	6	30
200	150	300	245	340	295	8 x 22	195	285	240	8 x 22	20	6	30
250	150	300	295	395	350	12 x 22	195	285	240	8 x 22	20	6	30
250	200	300	295	395	350	12 x 22	245	340	295	8 x 22	20	6	30
300	200	300	348	445	400	12 x 22	245	340	295	8 x 22	20	6	30
300	250	300	348	445	400	12 x 22	295	395	350	12 x 22	20	6	30

Special Designs:

Eccentric construction, larger nominal diameters and other sizes available on request.

Note:

For aggressive media, refer to resistance table.
The bellows must not be painted or insulated.

For further installation information, see page 60.