

# ➤➤ HOLLOW CONE NOZZLES

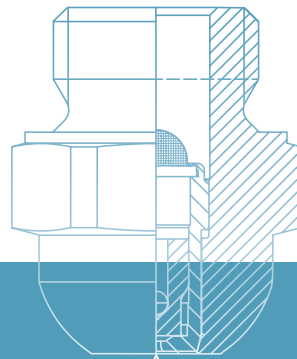

# ➤➤ HOLLOW CONE NOZZLES OVERVIEW OF TYPES

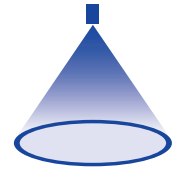

Hollow cone nozzles are used wherever fine droplets are required. A distinction is made between axial-flow hollow cone nozzles and tangential-flow hollow cone nozzles. Axial-flow hollow cone nozzles are mainly used for cooling, humidification and disinfecting, whilst tangential-flow hollow cone nozzles are traditionally used for humidification of air, dust control, sprinkling and foaming.

## Axial-flow hollow cone nozzles

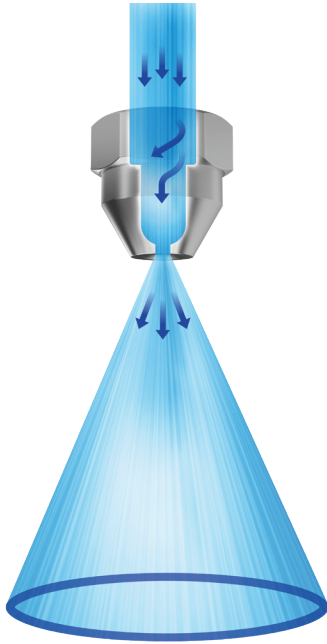

- High and controlled degree of atomization due to integrated swirl insert
- Narrow droplet spectrum
- Uniform atomization
- Large droplet surface area for mass transfer processes

## Tangential-flow hollow cone nozzles

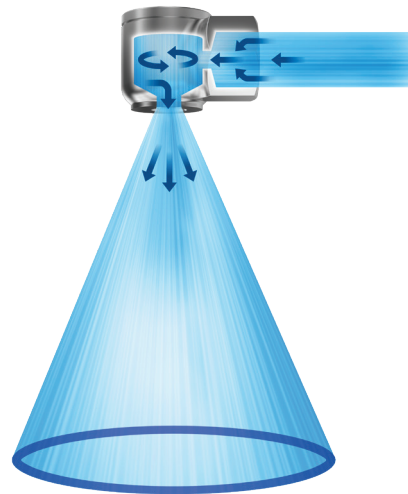







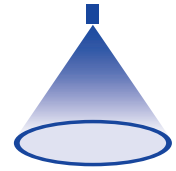

- Liquid rotation without swirl insert
- Maximum free passage making less susceptible to clogging
- Large free cross sections
- Operational reliability
- Coarse droplets that are larger than axial-flow hollow cone nozzles









# HOLLOW CONE NOZZLES OVERVIEW OF SERIES

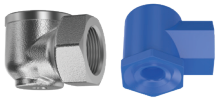

		Axial-flow hollow cone nozzles			
					
Series		220	226	214/216	2TR
Information on page		66	67	68	69
 <b>Flow rate at p = 2 bar</b>	<b>Very low</b> < 0.5 l/min	• (at p = 5 bar)	• (at p = 5 bar)	• (at p = 5 bar)	• (at p = 5 bar)
	<b>Low</b> 0.5 l/min–2.0 l/min			• (at p = 5 bar)	• (at p = 5 bar)
	<b>Medium</b> 2.0 l/min–10.0 l/min			• (at p = 5 bar)	
	<b>High</b> 10.0 l/min–50.0 l/min			• (at p = 5 bar)	
	<b>Very high</b> > 50.0 l/min				
 <b>Spray angle</b>	<b>Small</b> 45°				
	<b>Medium</b> 55°–95°	•	•	•	•
	<b>Large</b> 130°				
 <b>Nozzle material</b>	<b>Stainless steel</b>	•	•	•	
	<b>Brass</b>			•	
	<b>Plastic</b>				•
 <b>Nozzle connection</b>		1/4 BSPP	Assembly with retaining nut 3/8 BSPP	1/8 BSPP 3/8 BSPP	Assembly with retaining nut 3/8 BSPP

Tangential-flow hollow cone nozzles

					
302	302 with bayonet quick-release system	308	304/306/307	350	373 Ramp Bottom
70/71	66	74	75	76	77
•	•				
•	•	•		•	
•		•	•	•	
•			•		
					•
	•				
•	•	•	•		•
•	•		•	•	
•			•		•
•		•	•		
•	•			•	
3/8 BSPP	Assembly with bayonet quick-release system	3/8 BSPP	1/2 BSPP 3/4 BSPP	3/8 BSPP quick-release system	1 BSPP 1 1/4 BSPP 1 1/2 BSPP

# ➤ Axial-flow hollow cone nozzles Series 220

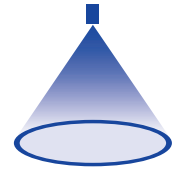

### Features:

- Extremely fine, fog-like atomization

### Applications:

- Humidification
- Cooling
- Disinfection
- Chemical engineering
- Adiabatic cooling

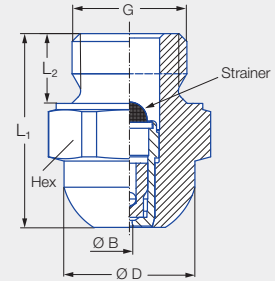
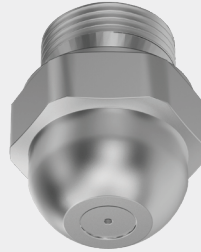

Series 220

Code	G	Dimensions [mm]				Weight [g]
		L <sub>1</sub>	L <sub>2</sub>	Ø D	Hex	
<b>AC</b>	1/4 BSPP	22.0	8.0	15.0	17	27.0

Spray angle	Ordering no.			Bore diameter B [mm]	Narrowest free cross section Ø [mm]	Strainer insert mesh size [mm]	V̇ water [l/min]								Spray diameter D [mm] (at p = 5 bar)				
	Type	Mat. no.					Code	p [bar]											
		1Y	11					2.0	3.0	5.0	7.0	10.0	20.0	50.0		100.0			
60°	Stainless steel 316L	Stainless steel 430F	1/4 BSPP	220.004	●	●	AC	0.10	0.10	0.04	–	–	<b>0.013</b>	0.015	0.018	0.026	0.041	0.058	120
				220.014	●	●	AC	0.15	0.15	0.04	–	0.015	<b>0.019</b>	0.022	0.027	0.038	0.060	0.085	140
				220.054	●	●	AC	0.20	0.15	0.04	0.017	0.021	<b>0.027</b>	0.032	0.038	0.054	0.085	0.121	160
80°	Stainless steel 316L	Stainless steel 430F	1/4 BSPP	220.085	●	●	AC	0.25	0.25	0.10	0.025	0.031	<b>0.040</b>	0.047	0.057	0.080	0.126	0.179	190
				220.125	●	●	AC	0.35	0.35	0.10	0.039	0.048	<b>0.062</b>	0.073	0.088	0.124	0.196	0.277	230
				220.145	●	●	AC	0.40	0.40	0.10	0.052	0.064	<b>0.082</b>	0.097	0.116	0.164	0.259	0.367	250
				220.165	●	●	AC	0.45	0.45	0.10	0.065	0.080	<b>0.103</b>	0.122	0.146	0.206	0.326	0.461	260
				220.185	●	●	AC	0.55	0.35	0.20	0.082	0.101	<b>0.130</b>	0.154	0.184	0.260	0.411	0.581	270
				220.205	●	●	AC	0.60	0.35	0.20	0.106	0.130	<b>0.168</b>	0.199	0.238	0.336	0.531	0.751	280
				220.245	●	●	AC	0.70	0.50	0.20	0.165	0.202	<b>0.261</b>	0.309	0.369	0.522	0.825	1.167	290
220.285	●	●	AC	0.90	0.55	0.20	0.247	0.302	<b>0.390</b>	0.461	0.552	0.780	1.233	1.744	300				

Mat. no.	Housing	Nozzle insert	Strainer
1Y	Stainless steel 316L	Stainless steel 316L	Stainless steel 316L
11	Stainless steel 430F	Stainless steel 430F	Stainless steel 316L

The supplied and integrated strainer insert prevents clogging of the nozzle, thereby ensuring a long service life.

Conversion formula for this series:  $\dot{V}_2 = \dot{V}_1 \cdot \sqrt{\frac{p_2}{p_1}}$

Ordering Type + Material no. + Code = Ordering no.  
example: 220.004 + 1Y + AC = 220.004.1Y.AC

 Assembly accessories can be found in Chapter 9 "Accessories".

# ➤ Axial-flow hollow cone nozzles Series 226

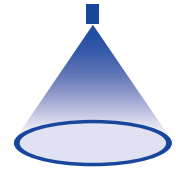

### Features:

- Extremely fine, fog-like atomization
- Assembly with retaining nut

### Applications:

- Humidification
- Cooling
- Disinfection
- Chemical engineering
- Adiabatic cooling

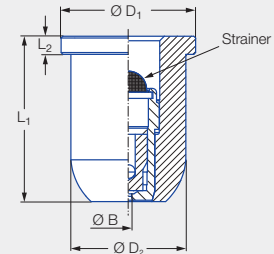

Series 226

Code	Dimensions [mm]				Weight [g]
	L <sub>1</sub>	L <sub>2</sub>	Ø D <sub>1</sub>	Ø D <sub>2</sub>	
Assembly with retaining nut 3/8 BSPP	18.00	2.00	14.80	12.65	20.00

Spray angle	Ordering no.		Bore diameter B [mm]	Narrowest free cross section Ø [mm]	Strainer insert mesh size [mm]	V̇ water [l/min]								Spray diameter D [mm] (at p = 5 bar)	
	Type	Mat. no.				p [bar]									
		16				2.0	3.0	5.0	7.0	10.0	20.0	50.0	100.0		H = 250 [mm]
60°	Stainless steel 303	226.004	●	0.10	0.10	0.04	–	–	<b>0.013</b>	0.015	0.018	0.026	0.041	0.058	120
		226.014	●	0.15	0.15	0.04	–	0.015	<b>0.019</b>	0.022	0.027	0.038	0.060	0.085	140
		226.054	●	0.20	0.15	0.04	0.017	0.021	<b>0.027</b>	0.032	0.038	0.054	0.085	0.121	160
80°	Stainless steel 303	226.085	●	0.25	0.25	0.10	0.025	0.031	<b>0.040</b>	0.047	0.057	0.080	0.126	0.179	190
		226.125	●	0.35	0.35	0.10	0.039	0.048	<b>0.062</b>	0.073	0.088	0.124	0.196	0.277	230
		226.145	●	0.40	0.40	0.10	0.052	0.064	<b>0.082</b>	0.097	0.116	0.164	0.259	0.367	250
		226.165	●	0.45	0.45	0.10	0.065	0.080	<b>0.103</b>	0.122	0.146	0.206	0.326	0.461	260
		226.185	●	0.55	0.35	0.20	0.082	0.101	<b>0.130</b>	0.154	0.184	0.260	0.411	0.581	270
		226.205	●	0.60	0.35	0.20	0.106	0.130	<b>0.168</b>	0.199	0.238	0.336	0.531	0.751	280
		226.245	●	0.70	0.50	0.20	0.165	0.202	<b>0.261</b>	0.309	0.369	0.522	0.825	1.167	290
226.285	●	0.90	0.55	0.20	0.247	0.302	<b>0.390</b>	0.461	0.552	0.780	1.233	1.744	300		

Mat. no.	Housing	Nozzle insert	Strainer
16	Stainless steel 303	Stainless steel 430F	Stainless steel 316L

The supplied and integrated strainer insert prevents clogging of the nozzle, thereby ensuring a long service life.

Conversion formula for this series:  $\dot{V}_2 = \dot{V}_1 \cdot \sqrt{\frac{p_2}{p_1}}$

Ordering Type + Material no. = Ordering no.  
example: 226.004 + 16 = 226.004.16

Assembly accessories can be found in Chapter 9 "Accessories".

# ➤ Axial-flow hollow cone nozzles

## Series 214/216

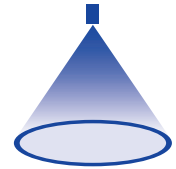

### Features:

- Fine, uniform atomization

### Applications:

- Cooling
- Gas washing
- Dust control
- Sprinkling
- Adiabatic cooling

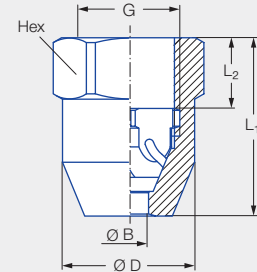

Series 214/216

Series	G	Dimensions [mm]				Weight [kg] (Brass)
		L <sub>1</sub>	L <sub>2</sub>	Ø D	Hex	
214	1/8 BSPP	18.0	6.0	16.0	17	27.0
216	3/8 BSPP	29.0	12.0	21.3	22	60.0

Spray angle	Ordering no.			Bore diameter B [mm]	Narrowest free cross section Ø [mm]	V̇ water [l/min]							Spray diameter D [mm] (at p = 5 bar)
	Type	Mat. no.				p [bar]							
		17	30			0.5	1.0	2.0	3.0	5.0	10.0	20.0	
60°	214.184	●	●	0.50	0.50	–	–	0.08	0.10	<b>0.13</b>	0.18	0.25	120
	216.324	●	●	1.00	1.00	–	0.28	0.40	0.49	<b>0.63</b>	0.89	1.26	190
	216.364	●	●	1.40	1.40	–	0.45	0.63	0.77	<b>1.00</b>	1.41	1.99	220
	216.404	●	●	2.00	2.00	–	0.71	1.00	1.22	<b>1.58</b>	2.24	3.16	240
80°	214.245	●	●	1.00	0.50	–	–	0.16	0.20	<b>0.25</b>	0.36	0.51	240
	214.305	●	●	1.80	0.50	–	0.23	0.32	0.39	<b>0.51</b>	0.72	1.01	320
90°	216.496	●	●	3.00	2.00	–	1.20	1.70	2.08	<b>2.69</b>	3.80	5.38	430
	216.566	●	●	4.00	2.00	–	1.77	2.50	3.06	<b>3.95</b>	5.59	7.91	430
	216.646	●	●	3.50	2.00	2.00	2.83	4.00	4.90	<b>6.32</b>	8.94	12.65	440
	216.686	●	●	4.00	2.00	2.50	3.54	5.00	6.12	<b>7.91</b>	11.18	15.81	450
	216.726	●	●	5.00	2.00	3.15	4.45	6.30	7.72	<b>9.96</b>	14.09	19.92	460
	216.776	●	●	6.00	2.00	4.30	6.00	8.50	10.40	<b>13.40</b>	19.00	26.90	470

Conversion formula for this series:  $\dot{V}_2 = \dot{V}_1 \cdot \sqrt{\frac{p_2}{p_1}}$

Ordering Type + Material no. = Ordering no.  
example: 214.184 + 17 = 214.184.17



Assembly accessories can be found in Chapter 9 "Accessories".



# ➤ Axial-flow hollow cone nozzles Series 2TR

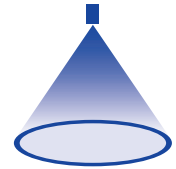

### Features:

- Fine, uniform atomization
- Assembly with retaining nut

### Applications:

- Sprinkling
- Adiabatic cooling
- Cooling
- Humidification of air

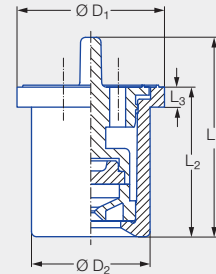

Series 2TR

Code	Dimensions [mm]					Weight [kg]
	L <sub>1</sub>	L <sub>2</sub>	L <sub>3</sub>	Ø D <sub>1</sub>	Ø D <sub>2</sub>	
Assembly with retaining nut 3/8 BSPP	20.0	15.0	2.0	14.8	11.9	3.0

Spray angle	Ordering no.		Color	Bore diameter B [mm]	Narrowest free cross section Ø [mm]	V̇ water [l/min]						Spray diameter D [mm] (at p = 5 bar)
	Type	Mat. no.				p [bar]						
		C8				Housing: POM Insert: Ceramic	1.0	2.0	3.0	5.0	7.0	10.0
80°	2TR.245	●	Purple	0.65	0.55	–	0.16	0.20	<b>0.25</b>	0.30	0.36	220
	2TR.275	●	Black	0.80	0.70	0.16	0.22	0.27	<b>0.35</b>	0.41	0.49	260
	2TR.305	●	Orange	0.90	0.80	0.23	0.32	0.39	<b>0.51</b>	0.60	0.72	320
	2TR.345	●	Green	1.10	0.90	0.34	0.48	0.59	<b>0.76</b>	0.90	1.07	420
	2TR.365	●	Yellow	1.40	0.95	0.46	0.65	0.80	<b>1.03</b>	1.22	1.45	490
	2TR.405	●	Blue	1.70	1.10	0.69	0.97	1.19	<b>1.53</b>	1.81	2.17	530
	2TR.445	●	Red	2.00	1.20	0.89	1.26	1.55	<b>2.02</b>	2.37	2.83	550
	2TR.485	●	Brown	2.20	1.30	1.11	1.57	1.94	<b>2.50</b>	2.96	3.54	560

### Assembly example

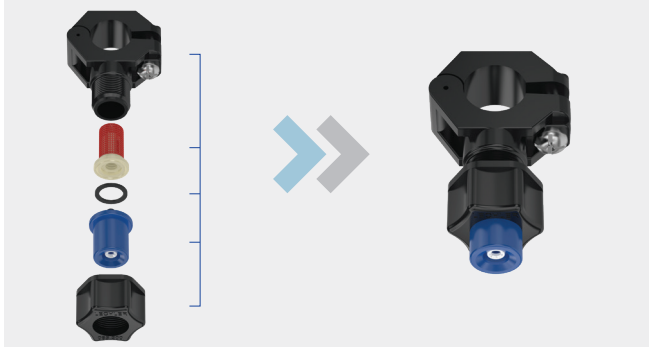

Conversion formula for this series:  $\dot{V}_2 = \dot{V}_1 \cdot \sqrt{\frac{p_2}{p_1}}$

Ordering Type + Material no. = Ordering no.  
example: 2TR.245 + C8 = 2TR.245.C8

Assembly accessories can be found in Chapter 9 "Accessories".

# ➤ Tangential-flow hollow cone nozzles, stainless steel/brass version

## Series 302

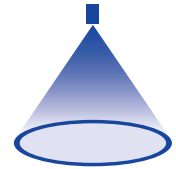

### Features:

- Uniform atomization
- Non-clogging nozzle without swirl insert

### Applications:

- Humidification of air
- Dust control
- Sprinkling
- Foam control
- Adiabatic cooling

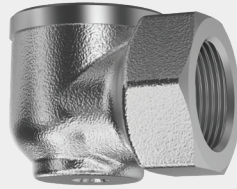

Series 302

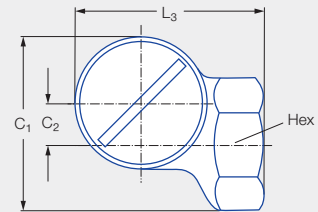
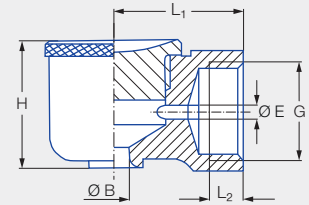

G	Dimensions [mm]							Weight [g] (Brass)
	C <sub>1</sub>	C <sub>2</sub>	H	L <sub>1</sub>	L <sub>2</sub>	L <sub>3</sub>	Hex	
3/8 BSPP	34.0	8.0	23.0	23.0	6.5	36.0	22	90.0

Spray angle	Ordering no.		Bore diameter B [mm]	Narrowest free cross section Ø [mm]	V̇ water [l/min]								Spray diameter D [mm] (at p = 2 bar)		
	Type	Mat. no.			p [bar]								H = 250 [mm]	H = 500 [mm]	
		1Y			30	0.5	1.0	2.0	3.0	5.0	7.0	10.0			
60°	302.364	•	•	1.50	1.50	0.32	0.45	0.63	0.77	1.00	1.18	1.41	280	420	
	302.464	•	•	2.00	2.00	0.70	0.99	1.40	1.71	2.21	2.62	3.13	280	460	
80°	302.545	•	•	4.90	2.30	1.12	1.58	2.24	2.74	3.54	4.19	5.01	360	660	
90°	302.606	•	•	4.60	4.00	1.58	2.23	3.15	3.86	4.98	5.89	7.04	470	810	
130°	302.368	•	•	3.00	1.00	0.32	0.45	0.63	0.77	1.00	1.18	1.41	660	1,080	
	302.468	•	•	5.00	1.70	0.70	0.99	1.40	1.71	2.21	2.62	3.13	810	1,370	
	302.548	•	•	5.00	2.50	1.12	1.58	2.24	2.74	3.54	4.19	5.01	960	1,640	
	302.608	•	•	5.00	3.50	1.58	2.23	3.15	3.86	4.98	5.89	7.04	1,060	1,800	
	302.668	•	•	7.50	3.60	2.25	3.18	4.50	5.51	7.12	8.42	10.06	1,120	1,950	
	302.748	•	•	7.50	4.80	3.55	5.02	7.10	8.70	11.23	13.28	15.88	1,160	2,150	

Conversion formula for this series:  $\dot{V}_2 = \dot{V}_1 \cdot \sqrt{\frac{p_2}{p_1}}$

Ordering Type + Material no. = Ordering no.  
example: 302.364 + 30 = 302.364.30

Assembly accessories can be found in Chapter 9 "Accessories".

# ➤ Tangential-flow hollow cone nozzles, plastic version

## Series 302

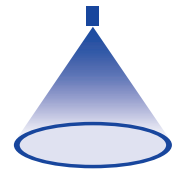

### Features:

- Uniform atomization
- Non-clogging nozzle without swirl insert

### Applications:

- Humidification of air
- Dust control
- Sprinkling
- Foam control
- Adiabatic cooling

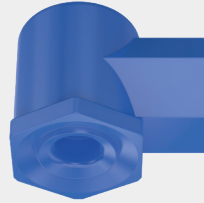

Series 302

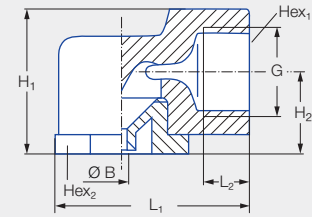

Type 302.32x-302.48x

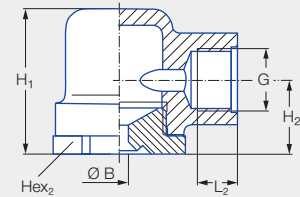

Type 302.52x-302.96x

Type	G	Dimensions [mm]						Weight [g]	p <sub>max</sub> [bar]
		H <sub>1</sub>	H <sub>2</sub>	L <sub>1</sub>	L <sub>2</sub>	Hex <sub>1</sub>	Hex <sub>2</sub>		
<b>302.32x-302.48x</b>	3/8 BSPP	27.5	16.5	43.5	10.0	22	22	13.0	5.0
<b>302.52x-302.96x</b>	3/8 BSPP	34.0	18.5	37.0	10.0	22	22	18.0	5.0

Spray angle	Ordering no.			Bore diameter B [mm]	Narrowest free cross section Ø [mm]	V̇ water [l/min]					Spray diameter D [mm] (at p = 2 bar)		
	Type	Mat. no.				p [bar]					 H = 250 [mm]    H = 500 [mm]		
		51	5E			53	0.5	1.0	2.0	3.0			5.0
60°	<b>302.364</b>	●		●	1.30	1.30	0.32	0.45	<b>0.63</b>	0.77	1.00	320	600
	<b>302.464</b>	●		●	1.95	1.95	0.70	0.99	<b>1.40</b>	1.71	2.21	330	620
90°	<b>302.326</b>	●	●		1.05	1.05	0.20	0.28	<b>0.40</b>	0.49	0.63	470	770
	<b>302.366</b>	●	●		1.30	1.30	0.32	0.45	<b>0.63</b>	0.77	1.00	480	790
	<b>302.406</b>	●	●	●	1.55	1.55	0.50	0.71	<b>1.00</b>	1.22	1.58	490	810
	<b>302.486</b>	●		●	2.10	2.10	0.80	1.13	<b>1.60</b>	1.96	2.53	510	850
	<b>302.526</b>	●		●	5.00	2.00	1.00	1.41	<b>2.00</b>	2.45	3.16	520	870
	<b>302.566</b>	●		●	5.00	2.40	1.25	1.77	<b>2.50</b>	3.06	3.95	520	900
	<b>302.606</b>	●		●	5.00	3.20	1.58	2.23	<b>3.15</b>	3.86	4.98	530	940
	<b>302.686</b>	●			7.50	3.40	2.50	3.54	<b>5.00</b>	6.12	7.91	540	1,010
	<b>302.766</b>	●			9.00	4.30	4.00	5.66	<b>8.00</b>	9.80	12.65	540	1,040
	<b>302.846</b>	●		●	11.00	5.20	6.25	8.84	<b>12.50</b>	15.31	19.67	540	1,050
	<b>302.886</b>	●	●	●	11.00	6.40	8.00	11.31	<b>16.00</b>	19.60	25.30	540	1,050
<b>302.966</b>	●			11.00	8.60	12.50	17.68	<b>25.00</b>	30.62	39.53	540	1,050	





Spray angle	Ordering no.			Bore diameter B [mm]	Narrowest free cross section Ø [mm]	V̇ water [l/min]					Spray diameter D [mm] (at p = 2 bar)		
	Type	Mat. no.				p [bar]							
		51	5E										53
		PA	PVDF			PP	0.5	1.0	2.0	3.0	5.0	H = 250 [mm]	H = 500 [mm]
130°	302.328		●		1.35	0.80	0.20	0.28	<b>0.40</b>	0.49	0.63	640	930
	302.368	●	●		1.85	1.10	0.32	0.45	<b>0.63</b>	0.77	1.00	660	1,010
	302.408	●	●		3.65	1.30	0.50	0.71	<b>1.00</b>	1.22	1.58	680	1,110
	302.488	●		●	5.20	1.60	0.80	1.13	<b>1.60</b>	1.96	2.53	720	1,250
	302.528	●			5.00	2.00	1.00	1.41	<b>2.00</b>	2.45	3.16	750	1,330
	302.568	●			5.00	2.40	1.25	1.77	<b>2.50</b>	3.06	3.95	780	1,410
	302.608	●	●	●	5.00	3.20	1.58	2.23	<b>3.15</b>	3.86	4.98	820	1,500
	302.648	●			7.50	3.00	2.00	2.83	<b>4.00</b>	4.90	6.32	860	1,590
	302.688	●			7.50	3.40	2.50	3.54	<b>5.00</b>	6.12	7.91	900	1,650
	302.728	●			7.50	4.10	3.15	4.45	<b>6.30</b>	7.72	9.96	920	1,700
	302.768	●			9.00	4.30	4.00	5.66	<b>8.00</b>	9.80	12.65	940	1,730
	302.848	●			11.00	5.20	6.25	8.84	<b>12.50</b>	15.31	19.76	960	1,760
	302.888	●		●	11.00	6.40	8.00	11.31	<b>16.00</b>	19.60	25.30	970	1,780
	302.968	●	●		11.00	8.60	12.50	17.68	<b>25.00</b>	30.62	39.53	1000	1,800

Conversion formula for this series:  $\dot{V}_2 = \dot{V}_1 \cdot \sqrt{\frac{p_2}{p_1}}$

Ordering Type + Material no. = Ordering no.  
 example: 302.328 + 5E = 302.328.5E



Assembly accessories can be found in Chapter 9 "Accessories".

# ➤ Tangential-flow hollow cone nozzles, plastic version with bayonet quick-release system Series 302

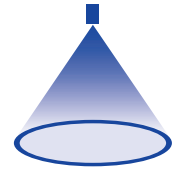

## Features:

- Uniform atomization
- Non-clogging nozzle without swirl insert
- Quick and secure assembly thanks to bayonet quick-release system
- Setting of spray direction

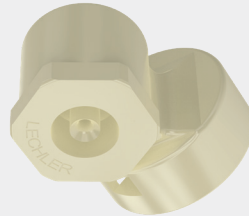

## Applications:

- Humidification of air
- Dust control
- Sprinkling
- Foam control
- Adiabatic cooling

Series 302

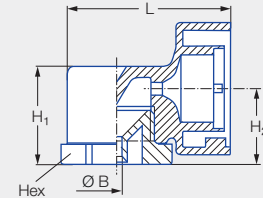

Type 302.32x-302.54x

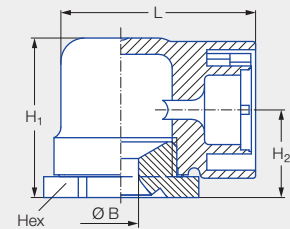

Type 302.606.51.KB

Type	Code	Dimensions [mm]				Weight [g]	P <sub>max</sub> [bar]
		H <sub>1</sub>	H <sub>2</sub>	L	Hex		
302.32x-302.54x	KB	21.8	16.8	36.0	22	12.0	5.0
302.606.51.KB	KB	34.0	19.0	42.0	30	19.0	5.0

Spray angle	Ordering no.				Bore diameter B [mm]	Narrowest free cross section Ø [mm]	V̇ water [l/min]					Spray diameter D [mm] (at p = 2 bar)	
	Type	Mat. no.		Code			p [bar]					H = 250 [mm]	H = 500 [mm]
		51	56				0.5	1.0	2.0	3.0	5.0		
45°	302.503	●		KB	2.05	2.05	0.90	1.27	1.80	2.20	2.85	210	430
60°	302.464		●	KB	1.95	1.95	0.70	0.99	1.40	1.71	2.21	290	540
80°	302.545		●	KB	2.30	2.30	1.12	1.58	2.24	2.74	3.54	450	810
90°	302.326	●	●	KB	1.05	1.05	0.20	0.28	0.40	0.49	0.63	400	720
	302.406	●	●	KB	1.55	1.55	0.50	0.71	1.00	1.22	1.58	400	740
	302.486	●		KB	2.10	2.10	0.80	1.13	1.60	1.96	2.53	450	800
	302.606	●		KB	5.00	3.20	1.58	2.23	3.15	3.86	4.98	530	1,000
	302.686		●	KB	7.50	3.40	2.50	3.54	5.00	6.13	7.91	540	1,010
130°	302.368		●	KB	1.30	1.30	0.32	0.45	0.63	0.77	1.00	660	1,100
	302.408	●	●	KB	2.00	2.00	0.50	0.71	1.00	1.22	1.58	680	1,200
	302.468	●		KB	2.40	2.40	0.70	0.99	1.40	1.71	2.21	680	1,250
	302.488	●		KB	2.75	2.75	0.80	1.13	1.60	1.96	2.53	720	1,300

Conversion formula for this series:  $\dot{V}_2 = \dot{V}_1 \cdot \sqrt{\frac{P_2}{P_1}}$

Ordering Type + Material no. + Code = Ordering no.  
example: 302.503 + 51 + KB = 302.503.51.KB

Assembly accessories can be found in Chapter 9 "Accessories".

# ➤ Tangential-flow hollow cone nozzles Series 308

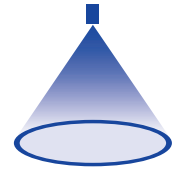

### Features:

- Uniform atomization
- Non-clogging nozzle without swirl insert
- Adjustable flow rate

### Applications:

- Humidification of air in air washers
- Dust control
- Spraying onto filters
- Foam control
- Cooling

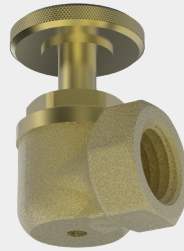

Series 308

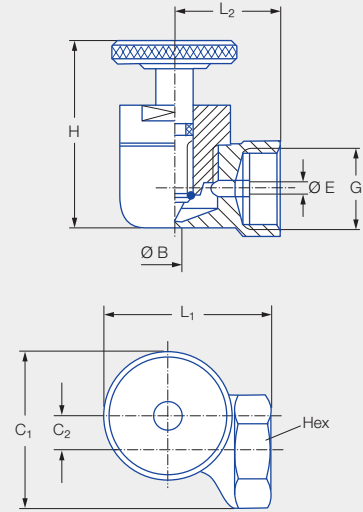

G	Dimensions [mm]						Weight [g]
	C <sub>1</sub>	C <sub>2</sub>	H	L <sub>1</sub>	L <sub>2</sub>	Hex	
3/8 BSPP	34.0	8.0	40.0	36.0	23.0	22	150.0

Spray angle	Ordering no.		Bore diameter B [mm]	Narrowest free cross section Ø [mm]	V <sub>max</sub> water [l/min]						Spray diameter D [mm] (at p = 2 bar)	
	Type	Mat. no.			p [bar]							
		30			0.3	0.5	1.0	2.0	5.0	10.0		
90°	308.466	●	2.00	2.00	0.54	0.70	1.00	1.40	2.21	3.13	440	830
	308.606	●	4.00	4.00	1.22	1.58	2.23	3.15	4.98	7.04	460	850

Conversion formula for this series:  $\dot{V}_2 = \dot{V}_1 \cdot \sqrt{\frac{p_2}{p_1}}$

Ordering Type + Material no. = Ordering no.  
example: 308.466 + 30 = 308.466.30

Assembly accessories can be found in Chapter 9 "Accessories".

# ➤ Tangential-flow hollow cone nozzles

## Series 304/306/307

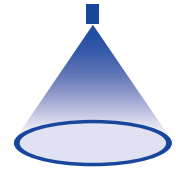

### Features:

- Uniform atomization
- Non-clogging nozzle without swirl insert

### Applications:

- Storage tank cooling
- Foam control
- Dust control
- Surface spraying
- Absorption

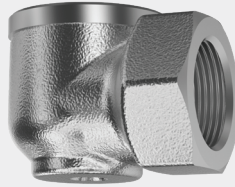

Series 304/306/307

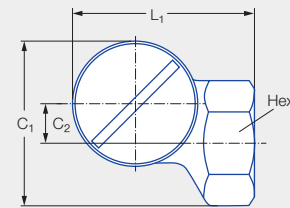
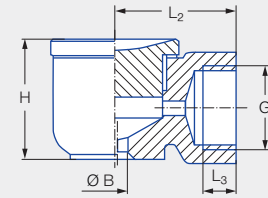

Series	G	Dimensions [mm]							Weight [g] (Brass)
		C <sub>1</sub>	C <sub>2</sub>	H	L <sub>1</sub>	L <sub>2</sub>	L <sub>3</sub>	Hex	
<b>304</b>	1/2 BSPP	43.0	11.0	33.0	46.0	30.0	11.0	27	205.0
<b>306/307</b>	3/4 BSPP	54.0	13.0	43.0	60.0	40.0	13.0	36	410.0

Spray angle	Ordering no.		Bore diameter B [mm]	Narrowest free cross section Ø [mm]	G ISO 228	V̇ water [l/min]							Spray diameter D [mm] (at p = 2 bar)		
	Type	Mat. no.				p [bar]							H = 250 [mm]	H = 500 [mm]	
		1Y				30	0.5	1.0	2.0	3.0	5.0	7.0			10.0
90°	<b>304.706</b>	●	●	5.10	5.10	1/2	2.80	3.96	<b>5.60</b>	6.86	8.85	10.48	12.52	500	1,000
	<b>304.796</b>	●	●	8.90	6.00	1/2	4.75	6.72	<b>9.50</b>	11.64	15.02	17.77	21.24	500	1,000
	<b>306.906</b>	●	●	9.00	9.00	3/4	9.00	12.73	<b>18.00</b>	22.05	28.46	33.67	40.25	550	1,050
	<b>306.976</b>	●	●	13.50	10.00	3/4	13.25	18.74	<b>26.50</b>	32.46	41.90	49.58	59.26	550	1,050
130°	<b>304.818</b>		●	12.00	5.00	1/2	5.30	7.50	<b>10.60</b>	12.98	16.76	19.83	23.70	1,200	2,100
	<b>304.898</b>	●	●	12.00	7.00	1/2	8.50	12.02	<b>17.00</b>	20.82	26.88	31.80	38.01	1,250	2,200
	<b>306.978</b>		●	19.00	7.30	3/4	13.25	18.74	<b>26.50</b>	32.46	41.90	49.58	59.26	1,300	2,350
	<b>307.018</b>	●	●	19.00	8.60	3/4	16.75	23.69	<b>33.50</b>	41.03	52.97	62.67	74.91	1,300	2,350

Conversion formula for this series:  $\dot{V}_2 = \dot{V}_1 \cdot \sqrt{\frac{P_2}{P_1}}$

Ordering Type + Material no. = Ordering no.  
 example: 304.706 + 1Y = 307.706.1Y

Assembly accessories can be found in Chapter 9 "Accessories".

# ➤ Tangential-flow hollow cone nozzles Series 350

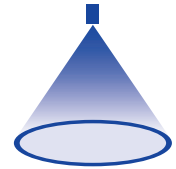

## Features:

- High performance nozzle for humidification of air
- Very narrow droplet spectrum
- Extremely uniform liquid distribution over the entire spray pattern
- Quick-release clamp unit available for pipe mounting

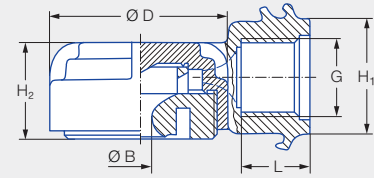
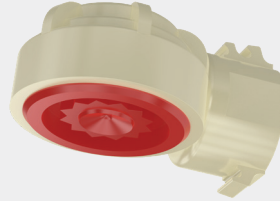

## Applications:

- Foam control
- Dust control
- Surface spraying
- Absorption

Series 350

G	Dimensions [mm]				Weight [g]	P <sub>max</sub> [bar]
	H <sub>1</sub>	H <sub>2</sub>	L	Ø D		
3/8 BSPP	24.0	20.0	14.0	37.0	37.0	20.0

Spray angle	Ordering no.		Bore diameter B [mm]	Narrowest free cross section Ø [mm]	V̇ water [l/min]							Spray diameter D [mm] (at p = 2 bar)	
	Type	Mat. no.			p [bar]							H = 250 [mm]	H = 500 [mm]
		56			0.5	1.0	2.0	3.0	5.0	7.0	10.0		
130°	350.368	●	1.55	0.70	0.32	0.45	0.63	0.77	1.00	1.18	1.41	950	1,250
	350.608	●	5.00	1.40	1.58	2.23	3.15	3.86	4.98	5.89	7.04	990	1,950

## Accessories:

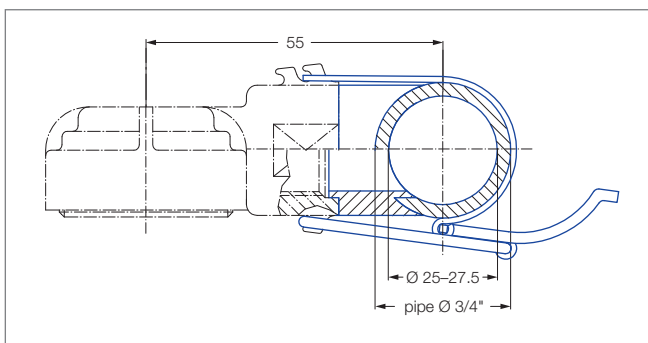

Recommended bore diameter 18 mm.

Quick-release clamp unit: Ordering no. 035.030.15.05.00.0.

Consisting of: Stainless steel clamp, polyurethane gasket.

Conversion formula for this series:  $\dot{V}_2 = \dot{V}_1 \cdot \sqrt{\frac{p_2}{p_1}}$

Ordering Type + Material no. = Ordering no.  
example: 350.368 + 56 = 350.368.56

 Assembly accessories can be found in Chapter 9 "Accessories".



# ➤ Eccentric hollow cone nozzles Series 373 Ramp Bottom

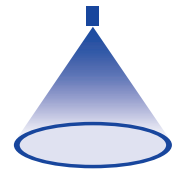

### Features:

- Fine, uniform atomization even at low pressure
- Patented swirl chamber with built-in ramp extends service life

### Applications:

- Gas cooling
- Water recooling
- Dust control

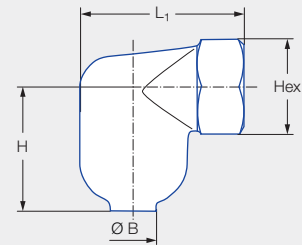
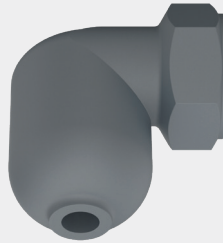

Series 373

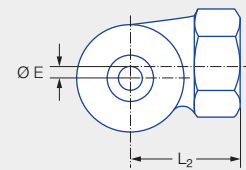
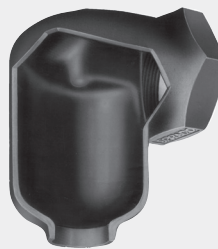

Code	G	Dimensions [mm]					Weight [g]
		H	L <sub>1</sub>	L <sub>2</sub>	Ø E	Hex	
<b>AN</b>	1 BSPP	52.0	67.0	45.0	6.3	41	285.0
<b>AQ</b>	1 1/4 BSPP	65.0	77.0	51.0	7.9	48	570.0
<b>AS</b>	1 1/2 BSPP	81.0	97.0	65.0	7.9	58	900.0

Spray angle	Ordering no.				Bore diameter B [mm]	V̇ water [l/min]						Spray diameter D [mm] (at p = 2 bar)		
	Type	Mat. no.	Code			p [bar]						H = 500 [mm]	H = 1,000 [mm]	
		17	1 BSPP	1 1/4 BSPP		1 1/2 BSPP	0.3	0.5	1.0	<b>2.0</b>	5.0			10.0
80°	<b>373.115</b>	●	<b>AN</b>			11.40	24.40	31.50	44.55	<b>63.00</b>	99.61	140.87	670	1,200
	<b>373.175</b>	●	<b>AN</b>			12.90	30.98	40.00	56.57	<b>80.00</b>	126.49	178.89	800	1,450
	<b>373.235</b>	●		<b>AQ</b>		16.20	45.70	59.00	83.44	<b>118.00</b>	186.57	263.86	750	1,300
	<b>373.285</b>	●		<b>AQ</b>		20.50	61.97	80.00	113.14	<b>160.00</b>	252.98	357.77	800	1,350
	<b>373.325</b>	●			<b>AS</b>	22.20	77.46	100.00	141.42	<b>200.00</b>	316.23	447.21	900	1,500
	<b>373.365</b>	●			<b>AS</b>	23.60	87.92	113.50	160.51	<b>227.00</b>	358.92	507.59	830	1,400

Conversion formula for this series:  $\dot{V}_2 = \dot{V}_1 \cdot \sqrt{\frac{p_2}{p_1}}$

Ordering Type + Material no. + Code = Ordering no.  
example: 373.115 + 17 + AN = 373.115.17.AN

Assembly accessories can be found in Chapter 9 "Accessories".

