

Isopad radiant heater

Isopad radiant heaters (IRH) have been designed as a reliable non-contact electric heat source providing temperatures up-to 1000°C. The uniform heat density makes them ideal for PECVD vacuum coating processes and they have been widely adopted in high quality applications such as thin film solar panel manufacture.

At the core is a mineral insulated (MI) heating cable which is manufactured into

a hermetically sealed heating element utilising laser welding technology, then formed to deliver optimum heat density and finally attached to a metallic plate which directs the heat to where it's required.

The lightweight, all-metal construction combined with the long element lengths made possible by MI cables minimise the number of vacuum feedthroughs required thus reducing the number of failure modes

in the final assembly. Additional reliability is achieved using multiple temperature sensors with the option of fully integrated and vacuum tested power and sensor feedthroughs .

Thermocoax can provide a customised radiant heater to specific customer design requirements or engineer from a simple design outline.

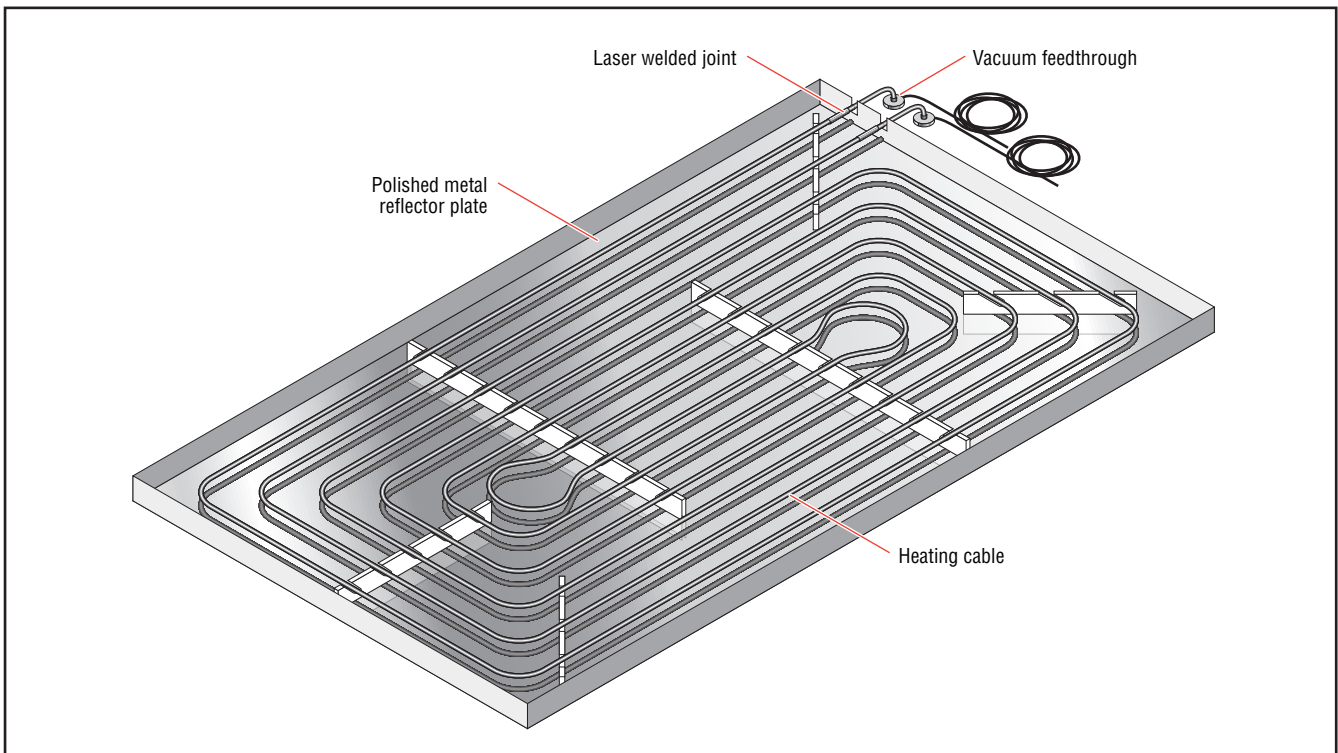

Area Specifications

Area classification	Nonhazardous, ordinary area
Ingress protection	IP68
Electrical protection class	Class I
Maximum withstand temperature (power off)	1000°C
Minimum installation temperature	-60°C

Heater Construction

Type	Resistance heating cable
Material	Various alloys
Material of insulation	Magnesium Oxide (MgO)
Material of outer sheath	Depending on design

Technical Data

Maximum operating voltage	300/500 Vac
Maximum operating temperature	1000°C

Options

Vacuum feedthrough of different style for heater and sensor connection; the length of the cold lead, the number of wires and optional vacuum feedthrough can be designed to customer requirements in terms of space, temperature and electrical needs.