



Drum pumps

Take out what's in.



**as easy as blinking,
innovative, simply perfect**

grün-pumps need no further explanation

We fulfil the expectations of our customers
with innovation and perfection.

If we are not immediately successful,
your problem becomes the problem of the managing director.

**Start up with grün-pumpen,
and you will advance.**

Dr. Thomas Sigel, managing director

**Selection of
a Drum pump:**

A drum pump always consists of
a pump tube and a drive motor.

1. Select a suitable pump tube material
after referring to the chemical resi-
stance table. From that you can also
find out if an explosion proof drum
pump is necessary or not.
2. Choose the right pump tube/motor
combination from the performance
curves in this catalogue.
3. Note down the type and order
number.
4. Select the necessary accessories
(page 28-34) and note down the order
number.
5. Take the prices out of the price list.

Table of contents

A		
Advantages of grün-drum pumps	page	4 5
B		
Pump tubes overview	page	6 7
Drive motors overview	page	8 9
Performance table for drum pumps	page	10 11
C		
Drum pumps in PP	page	12 13
Drum pumps in PVDF	page	14 15
Drum pumps in stainless steel and Hastelloy C	page	16 17
Multistage drum pumps in stainless steel and PP	page	18 19
Feed-screw drum pumps in stainless steel and Hastelloy C	page	20 21
Complete-drainage drum pumps in stainless steel and PP	page	22 23
Mixing drum pumps in stainless steel and PP	page	24 25
Explosion proof drum pumps in stainless steel and Hastelloy C	page	26 27
D		
Accessories	page	28 32
Flow meter	page	33 34
E		
Questionnaire	page	35



Advantages of grün-drum pumps



- **no inner-tube**
- easily accessible shaft
- easy to clean
- solid shaft
- robust mechanical seal



A

Advantages
of grün-
drum
pumps

- **multistage design**
- therefore lower speed,
less wear, less noise
and longer life
- more stages possible,
gives more pressure
- also **with feed-screw**
for medium viscosity liquids



Our Novum !

- **magnetic clutch**
- hermetically sealed
- for gaseous and
dangerous liquids
- no leakage



- **quick release coupling**
- speedy connection
- only 1/4 turn
- robust design
- rugged bow-gear coupling
- suitable for aggressive
environments



Pump tubes

The pump tubes are available in different materials: PP, PVDF, stainless steel and Hastelloy C. All these pump tubes have an easily accessible drive shaft (2). In the top section the solid shaft is sealed with a robust mechanical seal (4) directly under a

tandem ball-bearing. The coupling (7) above connects the motor drive shaft with the pump tube drive shaft. The coupling (6) which connects to the motor, is made of stainless steel. In the bottom section of the pump tube there is the pumping element

(3) directly under a slide bearing (5). These pumping elements are available in three different versions, selection is dependent on the liquid or the application.

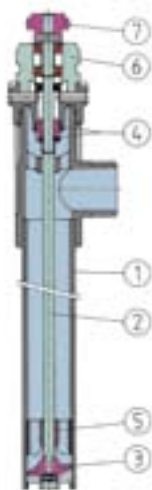

Version A with axial impeller

The axial impeller is designed to give a high delivery rate. It should be used when a fast liquid transfer is necessary.

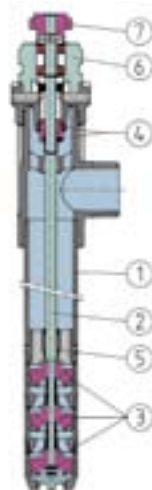

Version R with radial impeller

The 3 stage radial impeller design is able to reach a high delivery head. With the addition of further stages the delivery head can be greatly increased, or the speed of the drive motor can be reduced down to 2.800 rpm.

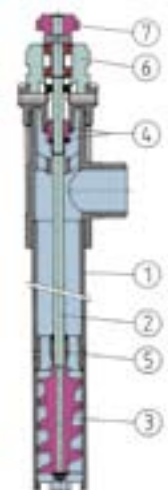

Version S with feed screw

The feed screw is mainly used for viscous liquids. This pump tube can operate with a high speed or a low speed motor. Smooth pumping of the liquid is guaranteed.

**TABLE OF MATERIALS
PUMP TUBES**

designation	pump tube PP	pump tube PVDF	pump tube SS	pump tube HC
1 tube	PP	PVDF	SS	HC
2 drive shaft	SS,HC	HC	SS	HC
3 axial impeller	PP	ETFE	ETFE	ETFE
3 radial impeller	PP	ETFE	ETFE	ETFE
3 feed screw	PP		PVDF	
4 mechanical seal	ceramic carbon, FPM	ceramic carbon, FPM	ceramic carbon, FPM	ceramic carbon, FPM
5 slide bearing	PTFE mod.	PTFE mod.	carbon	carbon
6 coupling piece	SS	SS	SS	SS
7 coupling	PA	PA	PA	PA

PP = Polypropylene
PVDF = Polyvinylidene fluoride
PA = Polyamide

SS = Stainless steel 1.4571
HC = Hastelloy C4
PTFE = modified Polytetrafluorethylene

All detailed pump tubes are also available in sealless version (SL)

Pump tube designation

(SL)-PP-A-(Mag)-SS-1000

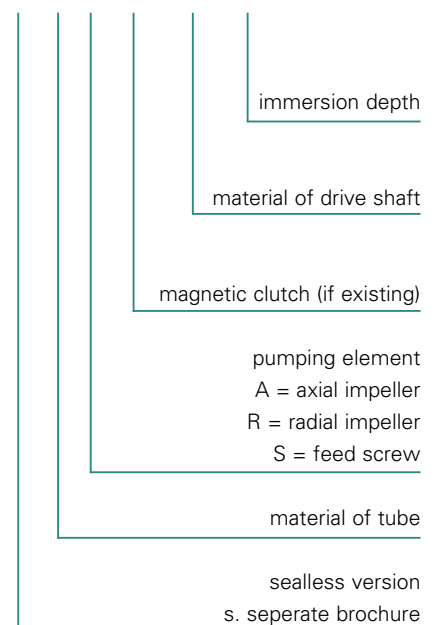

Pump tube with magnetic clutch

Each pump tube can be equipped with a magnetic clutch. In this way the mechanical seal is not necessary. The magnetic power will be transmitted through the isolations-

hell made of chemically- and wear-resistant PVDF resulting in a sealless pump tube, hermetically sealed against the atmosphere.

**TABLE OF MATERIALS
MAGNET PUMP TUBES**

designation	PP-Mag	PVDF-Mag	SS-Mag	HC-Mag
1 drive magnet	SmCo	SmCo	SmCo	SmCo
2 closing hat	PVDF	PVDF	PVDF	PVDF
3 magnet cover	PP	PVDF	PVDF	PVDF
4 magnet	SmCo	SmCo	SmCo	SmCo
5 slide washer	SS, HC	HC	SS	HC
6 slide bearing	PTFE mod.	PTFE mod.	carbon	carbon
7 o-ring	FPM	FPM	FPM	FPM

SmCo = samarium-cobalt-magnet

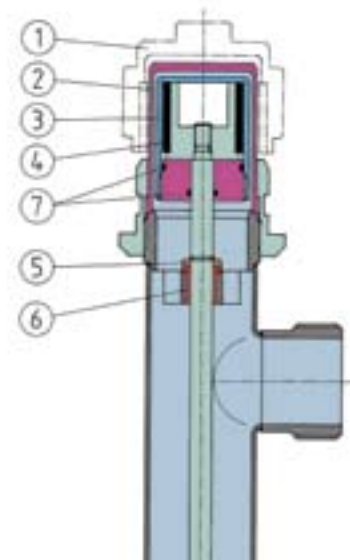

B

Pump tubes overview

Pump tubes for complete drum emptying

- nearly complete drainage
- residual quantity < 0,1 litre
- manual operated foot valve

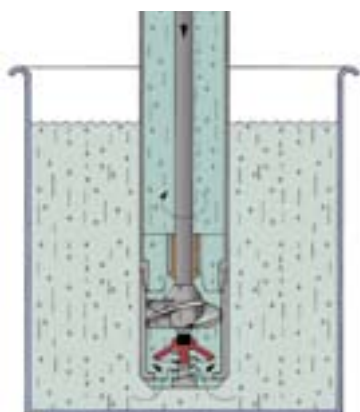

This pump tube is equipped with a foot valve, which avoids liquid runback. Using a lever above the hose connector, the foot valve can be opened or closed manually. During pumping and when the drum becomes empty, close the foot valve whilst the motor is still running (picture left). After switching off the motor, the pump tube complete with the trapped liquid can be removed and inserted into the next drum. The foot valve can now be opened with the drum pump ready for continued pumping.

For additional information see p.22/23.

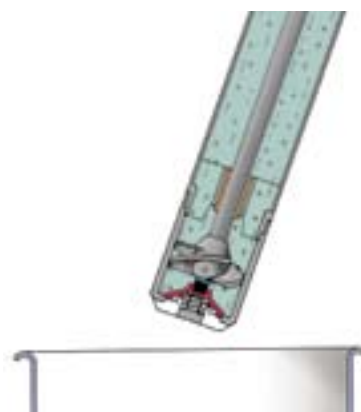

Mixing pump tube

- mixing and pumping in one unit
- homogeneous mixing
- powerful pumping

Emulsions, dispersions or suspensions such as paints and laquers tend to separate when left to stand. The heavier particles sink down to the bottom. The lighter parts will float to the top. Before discharging, the liquid has to be remixed, e. g. in a 200 litre drum with an opening perhaps only 50 mm diameter. This is no easy task. With our mixing drum pump this problem can easily be overcome. To mix, simply set the lever on the pump tube to mix. After the liquid has been mixed, you can gradually move the lever to pump in order to discharge the homogeneous liquid. Additional information see page 24/25.

A mixing pump tube in stainless steel can also be used for inflammable liquids (see page 26/27).

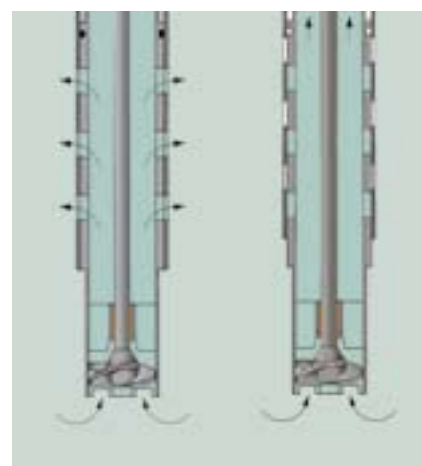

mixing

pumping

Drive motors

Universal motors p310 and p400



new+innovativ: magnetic clutch, speed reducer

These are robust and powerful commutator motors. With a speed of only 8.500 rpm they have a higher resistance to wear and a longer durability as faster running motors. Also, the lower speed has a positive effect on the noise level.

The motor housing is manufactured from chemically resistant polypropylene, which withstands extremely corrosive environments and demanding day-to-day use.

The quick release coupling that connects the motor and pump tube guarantees a speedy connection or disconnection. This is extremely important if there are many different pump tubes and only one drive motor in use.

- with bipolar on/off switch and singlepole thermal overcurrent release, 5 m cable.
- double insulated, VDE approved, splash water protected (IP 24) and interference suppressed.
- optional with a low voltage release (LVR) to prevent an unintentional starting up after a power failure or when plugging into the power supply.
- SR: optional with speed reducer
- MA: optional totally enclosed fan cooled

OPERATING DATA UNIVERSAL MOTORS

all motors available with magnetic clutch.
retrofit kit for magnetic clutch order-no. 760-0050

type	power	voltage	frequency	nominal current	speed rpm	speed re-ducer (SR)	protection class	Insulating class	weight kg	low voltage release (LVR)	order-no.
p310-A-230	520 W	230 V	50 Hz	2,5 A	8.500	no	IP 24	F	3,5	no	500-0017
p310-A-SR-230	520 W	230 V	50 Hz	2,5 A	0 - 8.500	yes	IP 24	F	3,5	no	500-0054
p310-230	520 W	230 V	50 Hz	2,5 A	8.500	no	IP 24	F	3,5	yes	500-0016
p400-A-230	850 W	230 V	50 Hz	4,5 A	8.500	no	IP 24	F	4,0	no	500-0024
p400-A-SR-230	800 W	230 V	50 Hz	4,5 A	0 - 8.500	yes	IP 24	F	4,0	no	500-0056
p400-A-MA-230	700 W	230 V	50 Hz	4,5 A	8.500	no	IP 54	F	5,8	no	500-0052
p400-230	850 W	230 V	50 Hz	4,5 A	8.500	no	IP 24	F	4,0	yes	500-0023
p310-A-115	520 W	110-120 V	50-60 Hz	5,0 A	8.500	no	IP 24	F	2,5	no	500-0029
p310-A-SR-115	520 W	110-120 V	50-60 Hz	5,0 A	0 - 8.500	yes	IP 24	F	2,5	no	500-0057
p310-115	520 W	110-120 V	50-60 Hz	5,0 A	8.500	no	IP 24	F	2,5	yes	500-0028
p400-A-115	850 W	110-120 V	50-60 Hz	9,0 A	8.500	no	IP 24	F	4,0	no	500-0026
p400-A-SR-115	850 W	110-120 V	50-60 Hz	9,0 A	0 - 8.500	yes	IP 24	F	4,0	no	500-0063
p400-115	850 W	110-120 V	50-60 Hz	9,0 A	8.500	no	IP 24	F	4,0	yes	500-0025

Explosion proof universal motor Ex700



This is a robust and powerful commutator motor. With a speed of only 8.000 rpm there is a higher resistance to wear and a longer durability than with faster running motors. The lower speed also has a positive effect on reducing the noise level. Explosion proof according protection class ATEX, Ex II 2G EEx de IIC T5, enclosed in a compression-proof, encapsulated inner housing made of aluminium. The outer housing is made of an impactresistant, antistatic synthetic material, making it more resistant to mechanical stress and electrostatic discharge. The quick release coupling being the connecting piece between motor and pump tube guarantees a speedy connection or disconnection. This is extremely important if there are many different pump tubes and only one

drive motor in use.

- explosion proof ATEX, Ex II 2G EEx de IIC T5.
- with bipolar on/off switch and single-pole thermal overcurrent release.
- With low voltage release to prevent an unintentional starting up after a power failure or when plugging into the power supply.
- complete with 5 m cable and in 230 volt version with a **non-explosion proof earthed plug**.

This plug is only for outside explosion-hazard areas. Inside the hazardous location an explosion proof plug together with an explosion proof socket must be used (see page 30/31).

OPERATING DATA EX-UNIVERSAL MOTORS

type	power	voltage	frequency	nominal current	speed rpm	protection class	insulating class	weight kg	low voltage release	ex-proof class	order-no.
Ex700-230	700 W	230 V	50 Hz	3,5 A	8.000	IP 54	F	6,0	yes	EEx de IIC T5	510-0010

Three-phase-motor pd500

This standardized three-phase-motor with a speed of 2.800 rpm will be used with **multistage pump tubes** and **feed screw pump tubes**. The very low speed for a drum pump ensures a long durability, a lower noise level and suitable for continuous operation.

The quick release coupling that connects the motor and pump tube guarantees a speedy connection or disconnection. This is extremely important when there are many different pump tubes for one motor, or to separate due to the weight.

- three-phase current 230/400 V, 50 Hz, protection class IP 55.
- single-phase current 230 V, 50 Hz, with capacitor.
- other voltages and other models possible.
- in explosion proof (ATEX) and non-explosion proof version.
- non-explosion proof motor with on/off protection switch.
- explosion proof motor with cable terminal box.



OPERATING DATA THREE-PHASE-MOTORS

type	power	voltage	frequency	nominal current	speed rpm	protection class	insulating class	weight kg	protection switch	ex-proof Ex II 2G	order-no.
pd500-1	0,37 kW	230 V	50 Hz	2,8 A	2.800	IP 55	B	5,0	yes	no	500-0042
pd500-3	0,37 kW	400 V	50 Hz	1,3 A	2.800	IP 55	B	4,0	no	no	500-0039
pd500-3 EEx	0,37 kW	400 V	50 Hz	1,3 A	2.800	IP 55	B	4,0	no	EEx e II T3	510-0009

B

Drive motors overview

Compressed air motor d600*



This is a safe, robust and versatile drive motor. In combination with a pump tube of ATEX category 1/2 made of stainless steel or HC it can be used in an explosion-hazard area (see page 26/27). The housing is made of aluminium with an acid proof paint finish. The quick release coupling that connects the motor and pump tube guarantees a speedy connection or disconnection. This is extremely important when there are many different pump tubes and only one motor.

- simple speed regulation with air pressure or air valve.
- 3 – 7 bar operating pressure.
- no problem with overload.
- with muffler.
- exhaust can be drained off through a separate hose.
- ATEX-Certification



OPERATING DATA COMPRESSED AIR MOTORS

type	power W	speed rpm	operating pressure bar	air consumption l/sec	air connecting	on/off switch	weight kg	order-no.
d600	600	8.000	3-7	10	R 1/4"	yes	1,7	520-0016

Performance table for drum pumps

(sealless version see separate brochure)



OPERATING DATA PERFORMANCE TABLE FOR DRUM PUMPS

drive motor ▶	p310...			p310-Mag...			p400...		
	delivery rate l/min	delivery head m wc	max. viscosity mPas	delivery rate l/min	delivery head m wc	max. viscosity mPas	delivery rate l/min	delivery head m wc	max. viscosity mPas
pump tube ▼									
PP-A	130	8	300	-	-	-	150	8	700
PP-R (FV*)	100	19	250	-	-	-	110	22	700
PP-A-Mag	-	-	-	130	8	50	-	-	-
PP-R-Mag (FV)	-	-	-	100	19	50	-	-	-
PVDF-A	130	8	300	-	-	-	150	8	700
PVDF-R (FV)	100	19	250	-	-	-	110	22	700
PVDF-A-Mag	-	-	-	130	8	50	-	-	-
PVDF-R-Mag (FV)	-	-	-	100	19	50	-	-	-
AtEx ** AtEx Niro-A	165	8	300	-	-	-	175	8	700
AtEx Niro-R (FV)	110	18	250	-	-	-	120	22	700
Niro-A-Mag	-	-	-	165	8	50	-	-	-
Niro-R-Mag (FV)	-	-	-	110	18	50	-	-	-
AtEx HC-A	165	8	300	-	-	-	175	8	700
HC-A-Mag	-	-	-	165	8	50	-	-	-
MP-PP-A	130	6	300	-	-	-	145	7	700
MP-PP-R	90	14	250	-	-	-	100	15	700
AtEx MP-Niro-A	130	6	300	-	-	-	145	7	700
AtEx MP-Niro-R	90	14	250	-	-	-	100	15	700
RE-PP-R	70	14	250	-	-	-	80	16	700
RE-Niro-R	70	14	250	-	-	-	80	16	700
PP-R/4 (FV)	-	-	-	-	-	-	110	27	550
PP-R/5 (FV)	-	-	-	-	-	-	110	30	450
AtEx Niro-R/4 (FV)	-	-	-	-	-	-	110	27	550
AtEx Niro-R/5 (FV)	-	-	-	-	-	-	110	30	450
PP-S	-	-	-	-	-	-	60	10	700
AtEx Niro-S	-	-	-	-	-	-	65	10	700
PVDF-S	-	-	-	-	-	-	60	10	700

delivery rate = maximum delivery rate at free outlet

delivery head = maximum delivery head at closed pressure line

measured values ± 10% determined with water 20 °C

*FV = foot valve optional

** inflammable liquids do only pump with ATEX pump tube and ATEX drive motor.



B

Performance table for drum pumps

			AtEx ^{**}						AtEx		
p400-Mag...			Ex700			pd500			d600		
delivery rate l/min	delivery head m wc	max. viscosity mPas	delivery rate l/min	delivery head m wc	max. viscosity mPas	delivery rate l/min	delivery head m wc	max. viscosity mPas	delivery rate l/min	delivery head m wc	max. viscosity mPas
-	-	-	-	-	-	-	-	-	115	7	500
-	-	-	-	-	-	-	-	-	90	18	400
150	8	50	-	-	-	-	-	-	-	-	-
110	22	50	-	-	-	-	-	-	-	-	-
-	-	-	-	-	-	-	-	-	115	7	500
-	-	-	-	-	-	-	-	-	90	18	400
150	8	50	-	-	-	-	-	-	-	-	-
110	22	50	-	-	-	-	-	-	-	-	-
-	-	-	150	8	600	-	-	-	120	7	500
-	-	-	100	17	500	-	-	-	90	18	400
175	8	50	-	-	-	-	-	-	-	-	-
120	22	50	-	-	-	-	-	-	-	-	-
-	-	-	150	8	400	-	-	-	120	7	500
175	8	50	-	-	-	-	-	-	-	-	-
-	-	-	-	-	-	-	-	-	110	6	500
-	-	-	-	-	-	-	-	-	80	15	400
-	-	-	125	8	600	-	-	-	110	6	500
-	-	-	90	14	500	-	-	-	80	15	400
-	-	-	-	-	-	-	-	-	80	15	400
-	-	-	-	-	-	-	-	-	80	15	500
-	-	-	-	-	-	32	3	400	90	20	350
-	-	-	-	-	-	32	4	400	90	25	250
-	-	-	100	25	500	32	3	400	90	20	350
-	-	-	100	28	400	32	4	400	90	25	250
-	-	-	-	-	-	33	9	1500	70	6	1000
-	-	-	80	11	700	33	9	1500	70	6	1000
-	-	-	-	-	-	33	9	1500	70	6	1000

Drum pumps in PP

(sealless version see separate brochure)

Product profile

A drum pump always consists of a pump tube and a drive motor. They are connected by a quick release coupling. All pump tubes can be combined with all motors.

For drum pump accessories see pages 28-34.



Advantages



- **no inner-tube**
- easily accessible shaft
- easy to clean
- solid shaft
- robust mechanical seal



- **magnetic clutch**
- hermetically sealed
- for gaseous and dangerous liquids
- no leakage



- **multistage design**
- therefore lower speed, less wear, lower noise and longer life
- more stages possible, gives more pressure
- also **with feed-screw** for medium viscosity liquids



- **quick release coupling**
- speedy connection
- only 1/4 turn
- robust design
- rugged bow-gear coupling
- suitable for aggressive environments

OPERATING DATA PUMP TUBES

pump tube	drive shaft	magnet clutch	number of impellers	t max °C	weight kg	immersion depth in mm		
						700	1000	1200
PP-A-SS	SS	no	1	50	1,3	610-0001	610-0002	610-0003
PP-A-HC	HC	no	1	50	1,3	610-0015	610-0016	610-0017
PP-R-SS	SS	no	3	50	1,4	615-0001	615-0002	615-0003
PP-R-HC	HC	no	3	50	1,4	615-0010	615-0011	615-0012
PP-A-Mag-SS	SS	yes	1	40	1,4	610-0004	610-0005	610-0006
PP-A-Mag-HC	HC	yes	1	40	1,4	610-0027	610-0028	610-0029
PP-R-Mag-SS	SS	yes	3	40	1,5	615-0004	615-0005	615-0006
PP-R-Mag-HC	HC	yes	3	40	1,5	615-0013	615-0014	615-0015

A = 1 axial impeller for high delivery rate

R = 3 radial impeller for high delivery head

Mag = magnetic clutch, PP = polypropylene, SS = stainless steel 1.4571,

HC = Hastelloy C-4, special immersion depth from 250 – 2500 mm possible

OPERATING DATA DRIVE MOTORS

universal motors	p310			p400				compressed air motor	d600
	p310	p310-A	p310-A-SR	p400	p400-A	p400-A-SR	p400-A-MA		
power	520 Watt	520 Watt	520 Watt	850 Watt	850 Watt	850 Watt	700 Watt	power	600 Watt
voltage	230V / 50Hz	230V / 50Hz	230V / 50Hz	230V / 50Hz	230V / 50Hz	230V / 50Hz	230V / 50Hz	air pressure	3 – 7 bar
protection class	IP 24	IP 24	IP 24	IP 24	IP 24	IP 24	IP 54	air consumption	10 l/sec
weight	3,5 kg	3,5 kg	3,5 kg	4,0 kg	4,0 kg	4,0 kg	5,8 kg	switch	yes
LVR	yes	no	no	yes	no	no	no	weight	1,7 kg
order-no.	500-0016	500-0017	500-0054	500-0023	500-0024	500-0056	500-0052	order-no.	520-0016

retrofit kit for magnetic clutch

order-no. 760-0050,
LVR = low voltage release,
other voltages see page 8



Applications

The drum pumps in PP are mainly used for pumping aggressive liquids like acids, caustics and other thin, low viscosity liquids.

Because of the ease of access to the shaft, the pump tube can be cleaned easily and quickly particularly with adhesive liquids.

Specially suitable for:

acids, caustics, thin-bodied oils, vegetable oils, fruit-juices, milk, paints, galvanic liquids, waste water and many others.

OPERATING DATA PUMP TUBES

pump tube ▶ drive motor ▼		PP-A SS/HC	PP-R SS/HC	PP-A-Mag SS/HC	PP-R-Mag SS/HC
p310...	characteristic curve no.	A1	R1	A1	R1
max. delivery rate	l/min	130	100	130	100
max. delivery head	m wc	8	19	8	19
max. viscosity	mPas	300	250	50	50
max. density	g/cm ³	1,3	1,6	1,1	1,1
weight motor + pump tube	kg	4,8	4,9	5,1	5,2
p400...	characteristic curve no.	A2	R2	A2	R2
max. delivery rate	l/min	150	110	150	110
max. delivery head	m wc	8	22	8	22
max. viscosity	mPas	700	700	50	50
max. density	g/cm ³	1,6	2,0	1,1	1,1
weight motor + pump tube	kg	5,3	5,4	5,6	5,7
d600	characteristic curve no.	A3	R3	A3	R3
max. delivery rate	l/min	110	80	110	80
max. delivery head	m wc	5	11	5	11
max. viscosity	mPas	500	400	50	50
max. density	g/cm ³	1,5	1,9	1,1	1,1
weight motor + pump tube	kg	3,0	3,1	3,3	3,4

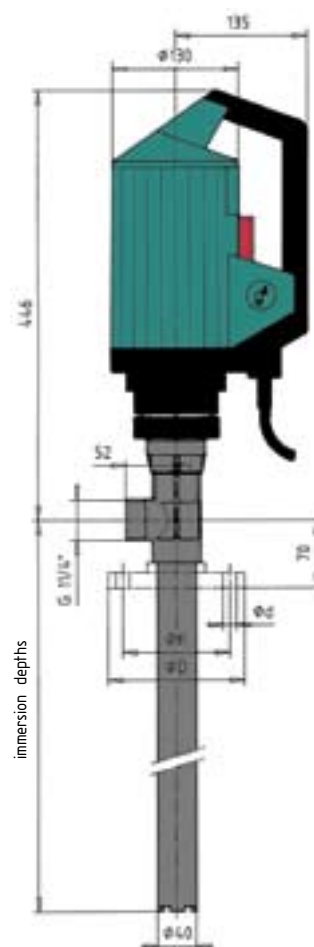

C

Drum pumps in PP

CHAR. CURVES A

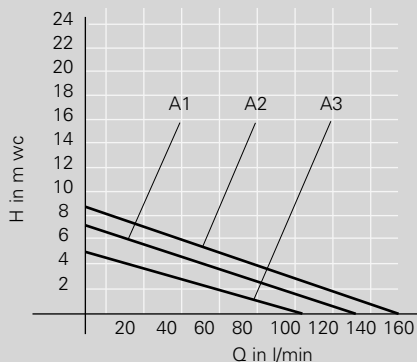

CHAR. CURVES R

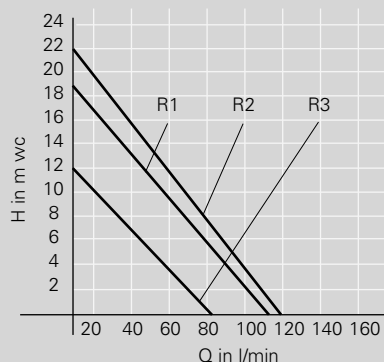

Important:

- These drum pumps are not explosion-proof.
- Do not pump inflammable liquids.
- For explosion-proof drum pumps see pages 26 and 27.

Notes:

Drum pumps in PVDF

(sealless version see separate brochure)

Product profile

A drum pump always consists of a pump tube and a drive motor. They are connected by a quick release coupling. All pump tubes can be combined with all motors.

For drum pump accessories see pages 28-34.

Advantages



- **no inner-tube**
- easily accessible shaft
- easy to clean
- solid shaft
- robust mechanical seal



- **magnetic clutch**
- hermetically sealed
- for gaseous and dangerous liquids
- no leakage



- **multistage design**
- therefore lower speed, less wear, lower noise and longer life
- more stages possible, gives more pressure
- also **with feed-screw** for medium viscosity liquids



- **quick release coupling**
- speedy connection
- only 1/4 turn
- robust design
- rugged bow-gear coupling
- suitable for aggressive environments

OPERATING DATA PUMP TUBES

pump tube	drive shaft	magnet clutch	number of impellers	t max. °C	weight kg	immersion depth in mm		
						700	1000	1200
PVDF-A	HC	no	1	120	1,8	620-0001	620-0002	620-0003
PVDF-R	HC	no	3	120	1,8	625-0001	625-0002	625-0003
PVDF-A-Mag	HC	yes	1	60	1,9	620-0004	620-0005	620-0006
PVDF-R-Mag	HC	yes	3	60	1,9	625-0004	625-0005	625-0006

A = 1 axial impeller for high delivery rate

R = 3 radial impeller for high delivery head

Mag = magnetic clutch PVDF = polyvinylidene fluoride HC = Hastelloy C-4

special immersion depth from 250 – 2500 mm possible

OPERATING DATA DRIVE MOTORS

universal motors	p310			p400				compressed air motor	d600
	p310	p310-A	p310-A-SR	p400	p400-A	p400-A-SR	p400-A-MA		
power	520 Watt	520 Watt	520 Watt	850 Watt	850 Watt	850 Watt	700 Watt	power	600 Watt
voltage	230V / 50Hz	230V / 50Hz	230V / 50Hz	230V / 50Hz	230V / 50Hz	230V / 50Hz	230V / 50Hz	air pressure	3 – 7 bar
protection class	IP 24	IP 24	IP 24	IP 24	IP 24	IP 24	IP 54	air consumption	10 l/sec
weight	3,5 kg	3,5 kg	3,5 kg	4,0 kg	4,0 kg	4,0 kg	5,8 kg	switch	yes
LVR	yes	no	no	yes	no	no	no	weight	1,7 kg
order-no.	500-0016	500-0017	500-0054	500-0023	500-0024	500-0056	500-0052	order-no.	520-0016

retrofit kit for magnetic clutch

order-no. 760-0050,
LVR = low voltage release,
other voltages see page 8



Applications

The drum pumps in PVDF are mainly used for pumping highly aggressive liquids like concentrated acids and caustics and other thin, low viscosity liquids.

Because of the ease of access to the shaft the pump tube can be cleaned easily and quickly particularly with adhesive liquids.

Specially suitable for: concentrated acids and caustics, chromic acid, nitric acid, fluoric acid and other heated acids and caustic liquids (see resistance table).

OPERATING DATA DRUM PUMPS

pump tube ▶ drive motor ▼		PVDF-A	PVDF-R	PVDF-A- Mag	PVDF-R- Mag
p310...	characteristic curve no.	A4	R4	A4	R4
max. delivery rate	l/min	130	100	130	100
max. delivery head	m wc	8	19	8	19
max. viscosity	mPas	300	250	50	50
max. density	g/cm ³	1,3	1,6	1,1	1,1
weight motor + pump tube	kg	5,3	5,4	5,6	5,7
p400...	characteristic curve no.	A5	R5	A5	R5
max. delivery rate	l/min	150	110	150	110
max. delivery head	m wc	8	22	8	22
max. viscosity	mPas	700	700	50	50
max. density	g/cm ³	1,6	2,0	1,1	1,1
weight motor + pump tube	kg	5,8	5,9	6,1	6,2
d600	characteristic curve no.	A6	R6	A6	R6
max. delivery rate	l/min	110	80	110	80
max. delivery head	m wc	5	11	5	11
max. viscosity	mPas	500	400	50	50
max. density	g/cm ³	1,5	1,9	1,1	1,1
weight motor + pump tube	kg	3,5	3,6	3,8	3,9

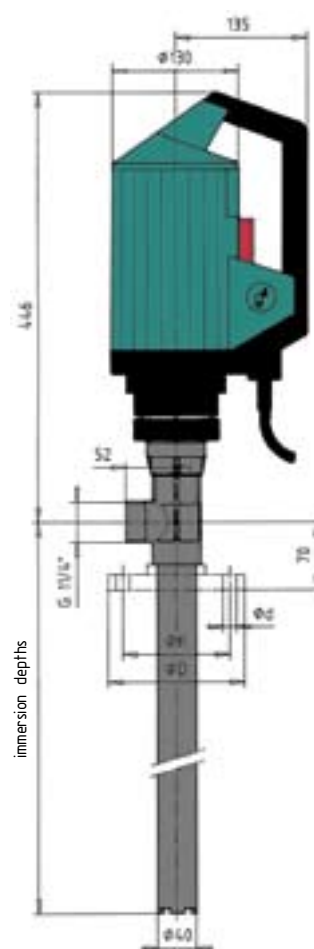

C

Drum pumps in PVDF

CHAR. CURVES A

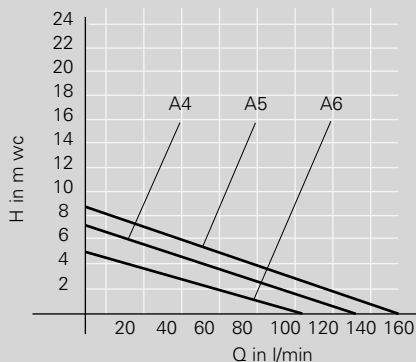

CHAR. CURVES R

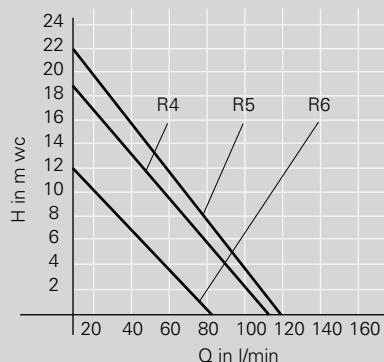

Important:

- These drum pumps are not explosion-proof.
- Do not pump inflammable liquids.
- For explosion-proof drum pumps see pages 26 and 27.

Notes:

Drum pumps in stainless steel (SS) and Hastelloy (HC)

(sealless version see separate brochure)

Product profile

A drum pump always consists of a pump tube and a drive motor. They are connected by a quick release coupling. All pump tubes can be combined with all motors.

For drum pump accessories see pages 28-34.

Advantages



- no inner-tube
- easily accessible shaft
- easy to clean
- solid shaft
- robust mechanical seal



- magnetic clutch
- hermetically sealed
- for gaseous and dangerous liquids
- no leakage



- multistage design
- therefore lower speed, less wear, lower noise and longer life
- more stages possible, gives more pressure
- also with feed-screw for medium viscosity liquids



- quick release coupling
- speedy connection
- only 1/4 turn
- robust design
- rugged bow-gear coupling
- suitable for aggressive environments

OPERATING DATA PUMP TUBES

pump tube	drive shaft	magnet clutch	number of impellers	t max. °C	weight kg	ATEX Ex II 1/2 G c T3		
						immersion depth in mm 700	1000	1200
SS-A	ATEX SS	no	1	100	3,0	630-0001	630-0002	630-0003
SS-R	ATEX SS	no	3	100	3,2	635-0001	635-0002	635-0003
SS-A-Mag	SS	yes	1	60	3,1	630-0004	630-0005	630-0006
SS-R-Mag	SS	yes	3	60	3,3	635-0004	635-0005	635-0006
HC-A	ATEX HC	no	1	100	3,0	640-0001	640-0002	640-0003
HC-A-Mag	HC	yes	1	60	3,1	640-0004	640-0005	640-0006

A = 1 axial impeller for high delivery rate

R = 3 radial impeller for high delivery head

Mag = magnetic clutch SS = stainless steel 1.4571 HC = Hastelloy C-4

special immersion depth from 200 – 3000 mm possible

OPERATING DATA DRIVE MOTORS

universal motors	p310	p310-A	p310-A-SR	p400	p400-A	p400-A-SR	p400-A-MA	compressed air motor	d600
power	520 Watt	520 Watt	520 Watt	850 Watt	850 Watt	850 Watt	700 Watt	power	600 Watt
voltage	230V / 50Hz	230V / 50Hz	230V / 50Hz	230V / 50Hz	230V / 50Hz	230V / 50Hz	230V / 50Hz	air pressure	3 – 7 bar
protection class	IP 24	IP 24	IP 24	IP 24	IP 24	IP 24	IP 54	air consumption	10 l/sec
weight	3,5 kg	3,5 kg	3,5 kg	4,0 kg	4,0 kg	4,0 kg	5,8 kg	switch	yes
LVR	yes	no	no	yes	no	no	no	weight	1,7 kg
order-no.	500-0016	500-0017	500-0054	500-0023	500-0024	500-0056	500-0052	order-no.	520-0016

retrofit kit for magnetic clutch

order-no. 760-0050,
LVR = low voltage release,
other voltages see page 8



Applications

The drum pumps in **SS** without explosion proof motor are mainly used for pumping aggressive liquids like acids, caustics and other thin, low viscosity liquids. Specially suitable for: acids, alkalis, thin-bodied oils, vegetable oils, fruit-juices, milk, paints, inks and many others (see resistance table).

The drum pumps in **HC** without explosion proof motor are mainly used for pumping highly aggressive liquids (see resistance table).

Because of the ease of access to the shaft the pump tube can be cleaned easily and quickly particularly with adhesive liquids. Metal drum pumps have the advantage of being more rugged and robust than plastic pumps.

OPERATING DATA DRUM PUMPS

pump tube ▶ drive motor ▼		SS-A HC-A	SS-R	SS-A-Mag HC-A-Mag	SS-R-Mag
p310...	characteristic curve no.	A7	R7	A7	R7
max. delivery rate	l/min	165	110	165	110
max. delivery head	m wc	8	18	8	18
max. viscosity	mPas	300	250	50	50
max. density	g/cm ³	1,3	1,6	1,1	1,1
weight motor + pump tube	kg	6,5	6,7	6,6	6,8
p400...	characteristic curve no.	A8	R8	A8	R8
max. delivery rate	l/min	175	120	175	120
max. delivery head	m wc	8	22	8	22
max. viscosity	mPas	700	700	50	50
max. density	g/cm ³	1,6	2,0	1,1	1,1
weight motor + pump tube	kg	7,0	7,2	7,1	7,3
d600	characteristic curve no.	A9	R9	A9	R9
max. delivery rate	l/min	110	80	110	80
max. delivery head	m wc	5	12	5	12
max. viscosity	mPas	500	400	50	50
max. density	g/cm ³	1,5	1,9	1,1	1,1
weight motor + pump tube	kg	4,7	4,9	4,8	5,0

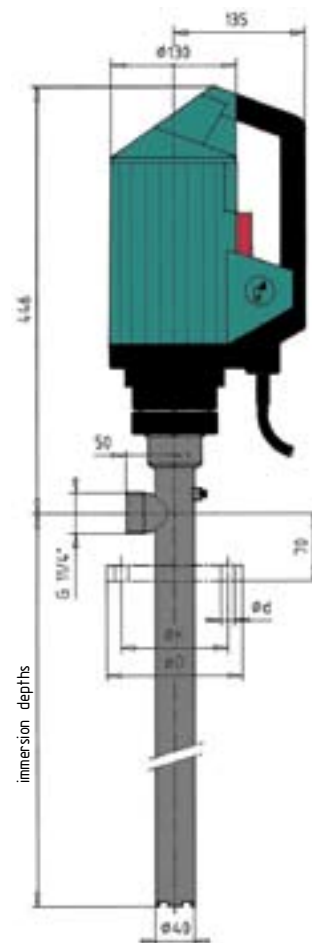

C

Drum pumps in stainless steel (SS) and Hastelloy (HC)

CHAR. CURVES A

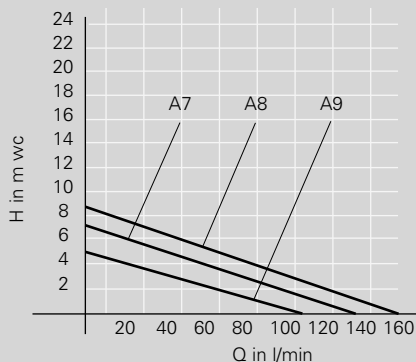

CHAR. CURVES R

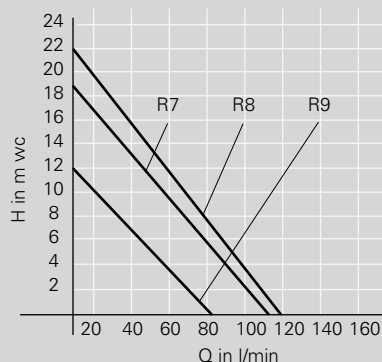

Important:

- These combinations of pump tubes and drive motors are nonlicensed for hazardous locations.
- For application in hazardous locations you must use an explosion proof pump tube and an explosive proof drive motor.
- For explosion-proof drum pumps see pages 26 and 27.

Notes:

Multistage drum pumps in stainless steel and PP



Product profile

A drum pump always consists of a pump tube and a drive motor. They will be connected by a quick release coupling. All pump tubes can be combined with all motors. Multistage pump tubes consists of several impellers in a row. For drum pump accessories see pages 28 – 34.

Advantages



- **no inner-tube**
- easily accessible shaft
- easy to clean
- solid shaft
- robust mechanical seal



- **multistage design**
- therefore lower speed, less wear, lower noise and longer life
- more stages possible, gives more pressure
- also **with feed-screw** for medium viscosity liquids



- **quick release coupling**
- speedy connection
- only 1/4 turn
- robust design
- rugged bow-gear coupling
- suitable for aggressive environments

OPERATING DATA PUMP TUBES

pump tube	drive shaft	number of impellers	t max. °C	weight kg	immersion depth in mm		
					700	1000	1200
PP-R/4-SS	SS	4	50	1,5	615-0025	615-0026	615-0027
PP-R/4-HC	HC	4	50	1,5	615-0028	615-0029	615-0030
PP-R/5-SS	SS	5	50	1,6	615-0031	615-0032	615-0033
PP-R/5-HC	HC	5	50	1,6	615-0034	615-0035	615-0036
SS-R/4	SS	4	100	3,2	635-0014	635-0015	635-0016
SS-R/5	SS	5	100	3,4	635-0017	635-0018	635-0019

PP = polypropylene, SS = stainless steel 1.4571, HC = Hastelloy C-4
special immersion depth on request

OPERATING DATA DRIVE MOTORS

	three-phase-motors		universal motors	p400	p400-A	p400-A-MA	compressed air motor	
	pd500-1	pd500-3						d600
power	0,37 kW	0,37 kW	power	850 Watt	850 Watt	700 Watt	power	600 Watt
voltage	230V / 50Hz	400 V / 50 Hz	voltage	230V / 50Hz	230V / 50Hz	230V / 50Hz	air pressure	3 – 7 bar
protection class	IP 55	IP 55	protection class	IP 24	IP 24	IP 54	air consumption	10 l/sec
protection switch	yes	no	weight	4,0 kg	4,0 kg	5,8 kg	switch	yes
weight	5,0 kg	4,0 kg	LVR	yes	no	no	weight	1,7 kg
order-no.	500-0042	500-0039	order-no.	500-0023	500-0024	500-0052	order-no.	520-0016

LVR = low voltage release, other voltages see page 8



Applications

The multistage pump tube fitted with a **three-phase-motor** should be used where **continuous operation** and/or a **low noise level** is required.

When fitted with a **universal motor** or a **compressed air motor** it should be used when a **high delivery head** is necessary.

Because of the ease of access to the shaft the pump tube can be cleaned easily and quickly particularly with adhesive liquids.

For chemical resistance of these pumps see separate resistance table.

OPERATING DATA DRUM PUMPS

pump tube ► drive motor ▼		PP-R/4 SS/HC	PP-R/5 SS/HC	SS-R/4	SS-R/5
pd500	characteristic curve no.	R41	R51	R41	R51
max. delivery rate	l/min	32	32	32	32
max. delivery head	m wc	3	4	3	4
max. viscosity	mPas	400	400	400	400
max. density	g/cm ³	1,6	1,5	1,6	1,5
weight motor + pump tube	kg	6,4	6,5	8,1	8,2
p400..	characteristic curve no.	R42	R52	R42	R52
max. delivery rate	l/min	110	110	110	110
max. delivery head	m wc	27	30	27	30
max. viscosity	mPas	550	450	550	450
max. density	g/cm ³	1,7	1,5	1,7	1,5
weight motor + pump tube	kg	5,4	5,5	7,1	7,2
d600	characteristic curve no.	R43	R53	R43	R53
max. delivery rate	l/min	80	80	80	80
max. delivery head	m wc	12	14	12	14
max. viscosity	mPas	350	250	350	250
max. density	g/cm ³	1,5	1,3	1,5	1,3
weight motor + pump tube	kg	3,1	3,2	4,8	4,9

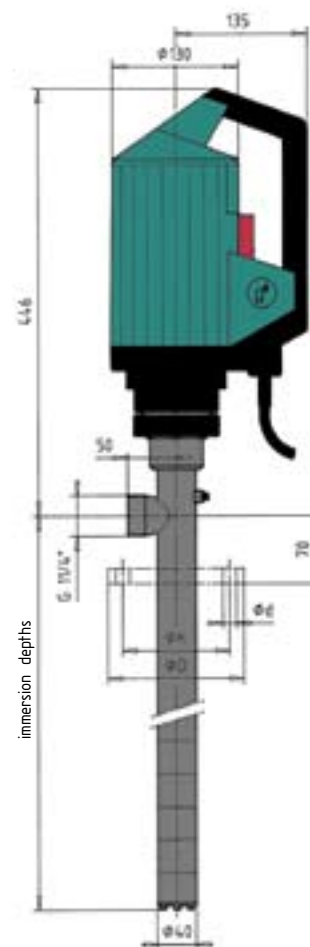

C

Multi-stage drum pumps in stainless steel and PP

CHAR. CURVES R 4-STAGES

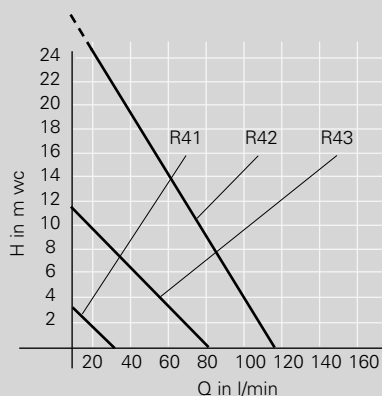

CHAR. CURVES R 5-STAGES

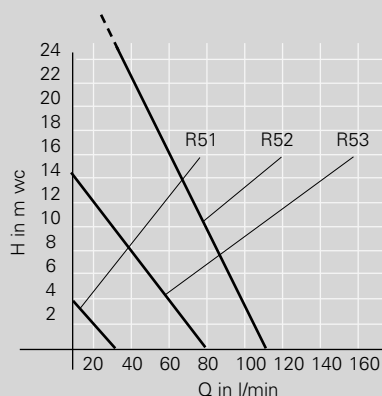

Important:

- These drum pumps are not explosion-proof.
- Do not pump inflammable liquids.
- For explosion-proof drum pumps see pages 26 and 27.

Notes:

Feed-screw drum pumps in stainless steel and PP

(sealless version see separate brochure)

Product profile

A drum pump always consists of a pump tube and a drive motor. They are connected by a quick release coupling. All pump tubes can be combined with all motors.

The feed-screw drum pump has a feed-screw pumping-element, rather than impellers. For drum pump accessories see pages 28-34.



Advantages



- no inner-tube
- easily accessible shaft
- easy to clean
- solid shaft
- robust mechanical seal



- with feed-screw
- for medium-viscous liquids
- smooth pumping of liquids
- low noise level with three-phase motor
- high performance with universal motor



- quick release coupling
- speedy connection
- only 1/4 turn
- robust design
- rugged bow-gear coupling
- suitable for aggressive environments

OPERATING DATA PUMP TUBES

pump tube	drive shaft	feed screw	t max. °C	weight kg	immersion depth in mm		
					700	1000	1200
PP-S-SS	SS	PP	50	1,5	610-0018	610-0019	610-0020
PP-S-HC	HC	PP	50	1,6	610-0045	610-0046	610-0047
SS-S 	SS	PVDF	100	3,5	630-0035	630-0036	630-0037

PP = polypropylene, PVDF = polyvinylidene fluoride
 SS = stainless steel 1.4571, HC = Hastelloy C-4
 special immersion depth on request

OPERATING DATA DRIVE MOTORS

	universal motors				three-phase-motors		
	p400	p400-A	p400-A-SR	p400-A-MA	pd500-1	pd500-3	pd500-3-EEx
power	850 Watt	850 Watt	850 Watt	700 Watt	0,37 kW	0,37 kW	0,37 kW
voltage	230V / 50Hz	230V / 50Hz	230V / 50Hz	230V / 50Hz	230V	430 V	400 V
protection class	IP 24	IP 24	IP 24	IP 54	IP 55	IP 55	IP 55
weight	4,0 kg	4,0 kg	4,0 kg	5,8 kg	5,0 kg	4,0 kg	4,0 kg
LVR	yes	no	no	no	yes	no	no
order-no.	500-0023	500-0024	500-0056	500-0052	500-0042	500-0039	510-0009

LVR = low voltage release, other voltages see page 8



Applications

The feed-screw drum pump is used for the smooth pumping of medium-viscosity liquids. They can be operated with a low-speed three-phase motor or a high-speed universal motor, according to the pumping requirements.

Because of the ease of access to the shaft the pump tube can be cleaned easily and quickly particularly with adhesive liquids. Specially suitable for paints, lacquers, mineral oils, vegetable oils, foods, cosmetics and many other products.

OPERATING DATA DRUM PUMPS

		PP-S SS/HC	SS-S
pump tube ▶			
drive motor ▼			
pd500	characteristic curve no.	S1	S1
max. delivery rate	l/min	10	10
max. delivery head	m wc	4	4
max. viscosity	mPas	1500	1500
max. density	g/cm ³	1,9	1,9
weight motor + pump tube	kg	6,5	8,5
p400...	characteristic curve no.	S2	S2
max. delivery rate	l/min	60	65
max. delivery head	m wc	10	10
max. viscosity	mPas	700	700
max. density	g/cm ³	1,9	1,9
weight motor + pump tube	kg	5,5	7,5

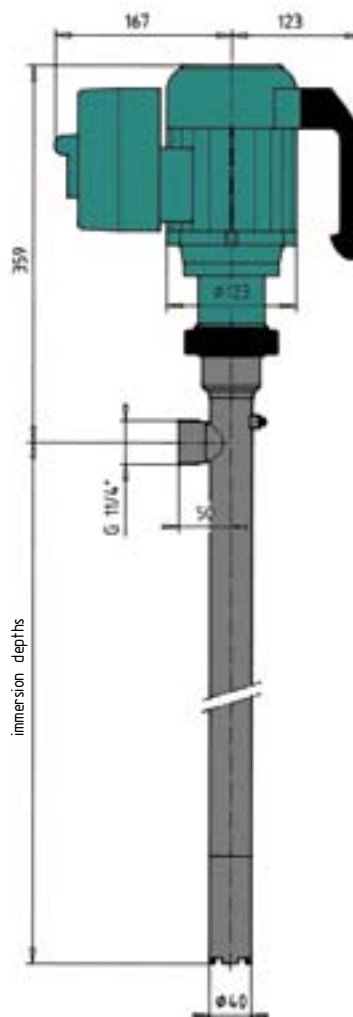

C

Feed-screw drum pumps in stainless steel and PP

CHAR. CURVES FOR VISCOUS LIQUIDS

CHAR. CURVES FOR WATER

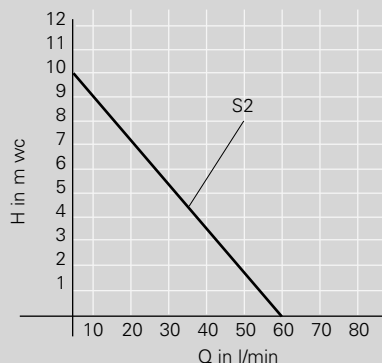
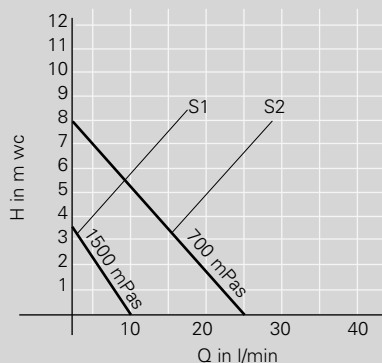

Important:

- These drum pumps are not explosion-proof.
- Do not pump inflammable liquids.
- For explosion-proof drum pumps see pages 26 and 27.

Notes:

Complete-drainage drum pumps in stainless steel and PP



Product profile

A drum pump always consists of a pump tube and a drive motor. They are connected by a quick release coupling. All pump tubes can be combined with all motors. The complete-drainage pump tube is fitted with a foot valve. This can be opened or closed manually with a lever.

For drum pump accessories see pages 28-34.

Advantages



- no inner-tube
- easily accessible shaft
- easy to clean
- solid shaft
- robust mechanical seal



- multistage design
- therefore lower speed, less wear, lower noise and longer life
- more stages possible, gives more pressure



- quick release coupling
- speedy connection
- only 1/4 turn
- robust design
- rugged bow-gear coupling
- suitable for aggressive environments

OPERATING DATA PUMP TUBES

pump tube	drive shaft	number of impellers	t max. °C	weight kg	immersion depth in mm		
					700	1000	1200
RE-PP-R-SS	SS	3	50	2,5	615-0016	615-0017	615-0018
RE-PP-R-HC	HC	3	50	2,5	615-0019	615-0020	615-0021
RE-SS-R	SS	3	100	4,2	635-0010	635-0011	635-0012

R = 3 radial impeller for high delivery head
 PP = polypropylene, SS = stainless steel 1.4571, HC = Hastelloy C-4
 special immersion depth on request

OPERATING DATA DRIVE MOTORS

universal motors	p310			p400				compressed air motor	d600
	p310	p310-A	p310-SR	p400	p400-A	p400-A-SR	p400-A-MA		
power	520 Watt	520 Watt	520 Watt	850 Watt	850 Watt	850 Watt	700 Watt	power	600 Watt
voltage	230V / 50Hz	230V / 50Hz	230V / 50Hz	230V / 50Hz	230V / 50Hz	230V / 50Hz	230V / 50Hz	air pressure	3 – 7 bar
protection class	IP 24	IP 24	IP 24	IP 24	IP 24	IP 24	IP 54	air consumption	10 l/sec
weight	3,5 kg	3,5 kg	3,5 kg	4,0 kg	4,0 kg	4,0 kg	5,8 kg	switch	yes
LVR	yes	no	no	yes	no	no	no	weight	1,7 kg
order-no.	500-0016	500-0017	500-0054	500-0023	500-0024	500-0056	500-0052	order-no.	520-0016

LVR = low voltage release, other voltages see page 8



Applications

The complete-drainage drum pump should be used when drums need to be completely emptied. Thereby the cost of waste material and contamination of the environment will be reduced. With materials in PP or SS, the pumps are suitable for handling a wide range of applications.

OPERATING DATA DRUM PUMPS

		RE-PP-R SS/HC	RE-SS-R
pump tube ▶			
drive motor ▼			
p310...	characteristic curve no.	R10	R10
max. delivery rate	l/min	70	70
max. delivery head	m wc	14	14
max. viscosity	mPas	250	250
max. density	g/cm ³	1,6	1,6
weight motor + pump tube	kg	5,8	7,7
p400...	characteristic curve no.	R11	R11
max. delivery rate	l/min	80	80
max. delivery head	m wc	16	16
max. viscosity	mPas	700	700
max. density	g/cm ³	2,0	2,0
weight motor + pump tube	kg	6,3	8,2
d600	characteristic curve no.	R12	R12
max. delivery rate	l/min	70	70
max. delivery head	m wc	10	10
max. viscosity	mPas	400	400
max. density	g/cm ³	1,9	1,9
weight motor + pump tube	kg	4,0	5,9

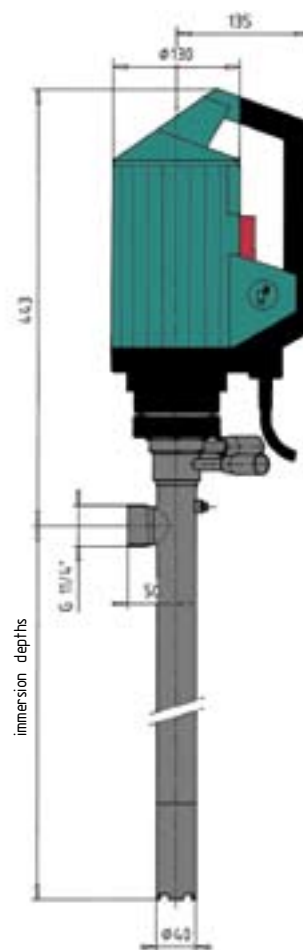

C

Complete-drainage drum pumps in stainless steel and PP

CHAR. CURVES R

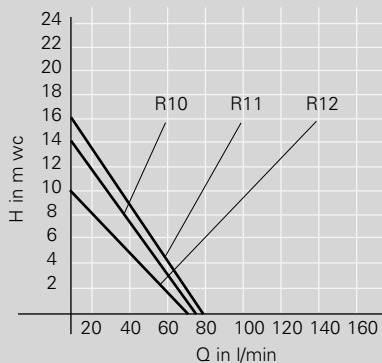

Important:

- These drum pumps are not explosion-proof.
- Do not pump inflammable liquids.
- For explosion-proof drum pumps see pages 26 and 27.

Notes:

Mixing drum pumps in stainless steel and PP

(sealless version see separate brochure)

Product profile

A drum pump always consists of a pump tube and a drive motor. They are connected by a quick release coupling. All pump tubes can be combined with all motors. The mixing drum pump is fitted with mixing apertures. By moving a sliding sleeve with a lever, these holes can be opened or closed. Open is for mixing inside the drum and closed is for pumping out of the drum. All this can be achieved with one unit.

For drum pump accessories see pages 28 – 34.

Advantages



- **no inner-tube**
- easily accessible shaft
- easy to clean
- solid shaft
- robust mechanical seal



- **magnetic clutch**
- hermetically sealed
- for gaseous and dangerous liquids
- no leakage



- **multistage design**
- therefore lower speed, less wear, lower noise and longer life
- more stages possible, gives more pressure
- also **with feed-screw** for medium viscosity liquids



- **quick release coupling**
- speedy connection
- only 1/4 turn
- robust design
- rugged bow-gear coupling
- suitable for aggressive environments

OPERATING DATA PUMP TUBES

pump tube	drive shaft	tube ø mm	number of impellers	t max °C	weight kg	immersion depth in mm		
						700	1000	1200
MP-PP-A	SS	50	1	50	2,3			
MP-PP-R	SS	50	3	50	2,3		on demand	
MP-SS-A	SS	50	1	100	4,2			
MP-SS-R	SS	50	3	100	4,5			

A = 1 axial impeller for high delivery rate
 R = 3 radial impeller for high delivery head
 PP = polypropylene, SS = stainless steel 1.4571
 special immersion depth on request

OPERATING DATA DRIVE MOTORS

universal motors	p310			p400				compressed air motor	d600
	p310	p310-A	p310-SR	p400	p400-A	p400-A-SR	p400-A-MA		
power	520 Watt	520 Watt	520 Watt	850 Watt	850 Watt	850 Watt	700 Watt	power	600 Watt
voltage	230V / 50Hz	230V / 50Hz	230V / 50Hz	230V / 50Hz	230V / 50Hz	230V / 50Hz	230V / 50Hz	air pressure	3 – 7 bar
protection class	IP 24	IP 24	IP 24	IP 24	IP 24	IP 24	IP 54	air consumption	10 l/sec
weight	3,5 kg	3,5 kg	3,5 kg	4,0 kg	4,0 kg	4,0 kg	5,8 kg	switch	yes
LVR	yes	no	no	yes	no	no	no	weight	1,7 kg
order-no.	500-0016	500-0017	500-0054	500-0023	500-0024	500-0056	500-0052	order-no.	520-0016

retrofit kit for magnetic clutch

order-no. 760-0050,
 LVR = low voltage release,
 other voltages see page 8



Applications

The mixing drum pump should be used for emulsions, dispersions or suspensions such as paints and lacquers. These liquids tend to separate when left to stand. With the mixing drum pump these liquids can first be mixed and then pumped with a single unit.

The pump tube in SS combined with an explosion-proof motor can be used for inflammable liquids (see page 26/27).

For chemical resistance of these pumps refer to the resistance table.

OPERATING DATA DRUM PUMPS

		MP-PP-A	MP-PP-R	MP-SS-A	MP-SS-R
pump tube ▶					
drive motor ▼					
p310...	characteristic curve no.	A15	R15	A15	R15
max. delivery rate	l/min	130	90	130	90
max. delivery head	m wc	6	14	6	14
max. viscosity	mPas	300	250	300	250
max. density	g/cm ³	1,3	1,6	1,3	1,6
weight motor + pump tube	kg	5,8	5,8	8,0	8,2
p400...	characteristic curve no.	A16	R16	A16	R16
max. delivery rate	l/min	145	100	145	100
max. delivery head	m wc	7	15	7	15
max. viscosity	mPas	700	700	700	700
max. density	g/cm ³	1,6	2,0	1,6	2,0
weight motor + pump tube	kg	6,3	6,3	8,5	8,7
d600	characteristic curve no.	A17	R17	A17	R17
max. delivery rate	l/min	110	70	105	70
max. delivery head	m wc	4	10	4	10
max. viscosity	mPas	500	400	500	400
max. density	g/cm ³	1,5	1,9	1,5	1,9
weight motor + pump tube	kg	4,0	4,0	6,2	6,4

CHAR. CURVES A

CHAR. CURVES R

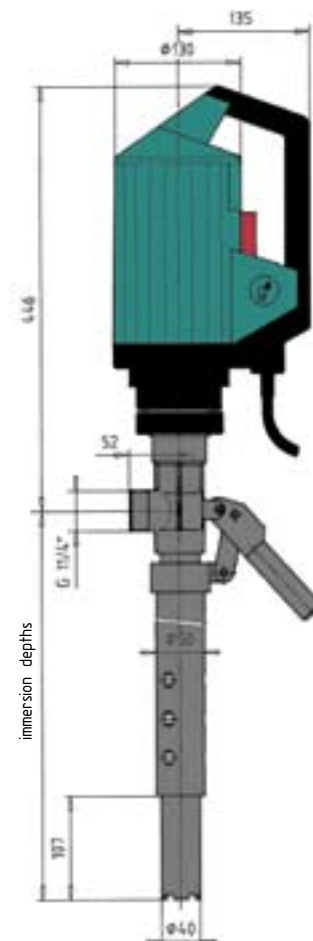
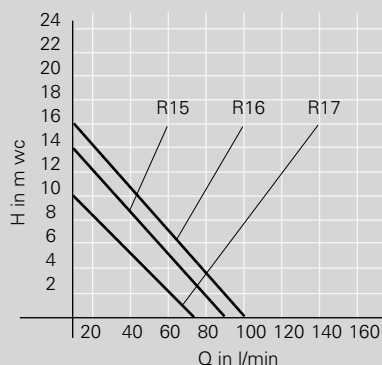
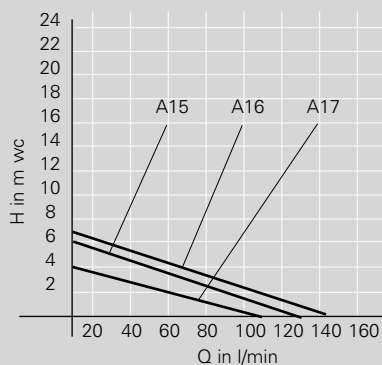

C

Mixing drum pumps in stainless steel and PP

Important:

- These drum pumps are not explosion-proof.
- Do not pump inflammable liquids.
- For explosion-proof drum pumps see pages 26 and 27.

Notes:

Explosion-proof drum pumps in SS and HC



(sealless version
see separate brochure)

Product profile

An explosion-proof drum pump always consists of a pump tube made of stainless steel or Hastelloy C of ATEX category 1/2 (licensed for „Zone 0“) and an explosion-proof drive motor of ATEX category 2 (licensed for „Zone 1“) according to IEC and VbF standards. Modern compressed air motors comply with the requirements of ATEX category 2 and can also be used inside a hazardous area. They are connected by a quick release coupling. All pump tubes can be combined with all motors.

Advantages



- no inner-tube
- easily accessible shaft
- easy to clean
- solid shaft
- robust mechanical seal



- multistage design
- therefore lower speed, less wear, lower noise and longer life
- more stages possible, gives more pressure



- quick release coupling
- speedy connection
- only 1/4 turn
- robust design
- rugged bow-gear coupling
- suitable for aggressive environments



OPERATING DATA PUMP TUBES

pump tube	drive shaft	number of impellers	t max °C	weight kg	ATEX Ex 2 II G 1/2 c T3		
					immersion depth in mm 700	1000	1200
SS-A	SS	1	100	3,0	630-0001	630-0002	630-0003
SS-R	SS	3	100	3,3	635-0001	635-0002	635-0003
HC-A	HC	1	100	3,2	640-0001	640-0002	640-0003
MP-SS-A	SS	1	100	4,2	630-0007	630-0008	630-0009
MP-SS-R	SS	3	100	4,5	635-0007	635-0008	635-0009
SS-S	SS	1	100	3,0	630-0035	630-0036	630-0037

A = 1 axial impeller for high delivery rate
R = 3 radial impeller for high delivery head
SS = stainless steel 1.4571, HC = Hastelloy C-4
special immersion depth on request

OPERATING DATA DRIVE MOTORS

universal motor	ATEX Ex 2 II G	
	Ex700	compressed air motor d600
power	700 Watt	power 600 Watt
voltage	230V / 50Hz	air pressure 3 – 7 bar
Ex-protection	EEx de IIC T5	Ex-protection yes
protection class	IP54	air consumption 10 l/sec
weight	6,0 kg	weight 1,7 kg
LVR	yes	switch yes
order-no.	510-0010	order-no. 520-0016

Please note:

Explosion proof plug system BBC, 3 pole
order-no. 815-0009



Applications

Explosion-proof drum pumps should be used for pumping inflammable liquids according to VbF or when an explosion-proof drum pump is specified.

Explosion-proof mixing drum pumps should be used for inflammable emulsions, dispersions or suspensions like paints and lacquers when mixing before pumping is necessary. When working with explosion-proof drum pumps, the **accessories** detailed on pages 30 and 31 should be used. For chemical resistance of these pumps refer to the resistance table.

OPERATING DATA DRUM PUMPS

pump tube ▶ drive motor ▼		SS-A HC-A	SS-R	MP-SS-A	MP-SS-R
Ex700	characteristic curve no.	A20	R20	A22	R22
max. delivery rate	l/min	150	100	125	90
max. delivery head	m wc	8	17	7	14
max. viscosity	mPas	600	500	600	500
max. density	g/cm ³	1,3	1,6	1,3	1,6
weight motor + pump tube	kg	9,0	9,2	10,2	10,5
d600	characteristic curve no.	A21	R21	A23	R23
max. delivery rate	l/min	110	80	105	70
max. delivery head	m wc	5	12	4	10
max. viscosity	mPas	500	400	500	400
max. density	g/cm ³	1,5	1,9	1,5	1,9
weight motor + pump tube	kg	4,7	4,9	5,9	6,2

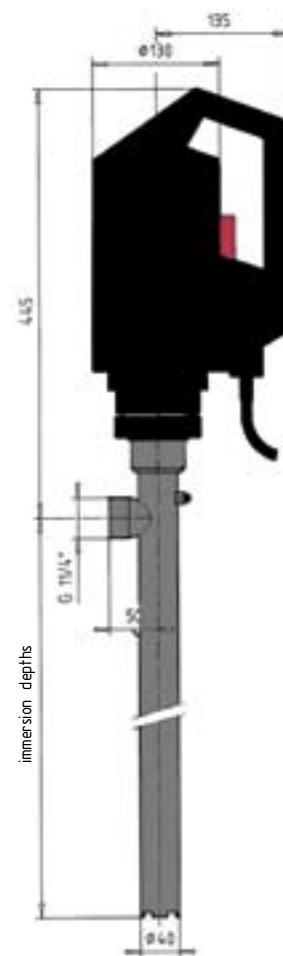

C

Explosion-proof drum pumps in SS and HC

CHAR. CURVES A

CHAR. CURVES R

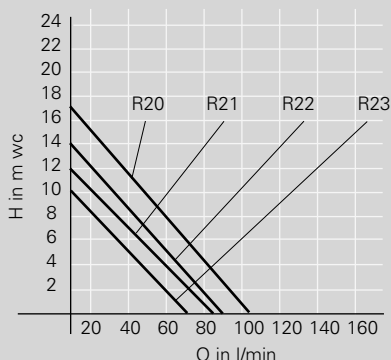
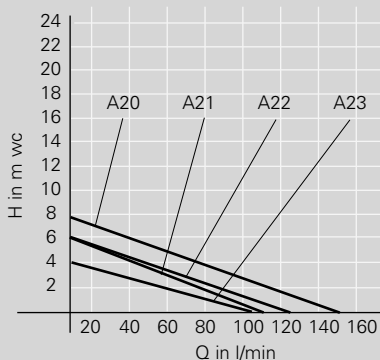

Notes:

Accessories

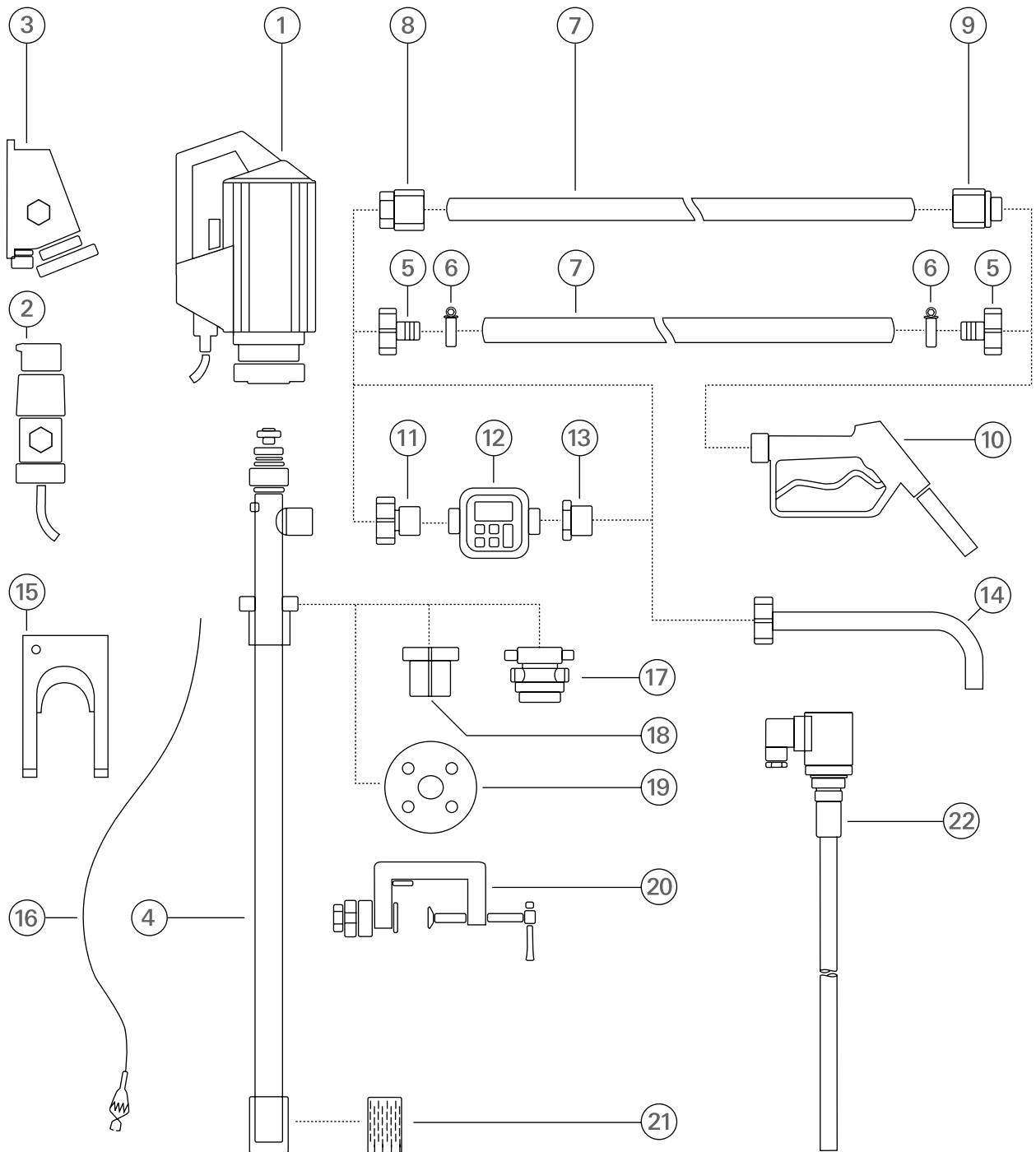

- 1 Drive motor
- 2 Explosion-proof plug
- 3 Explosion-proof socket
- 4 Pump tube
- 5 Hose connector
- 6 Hose clamps
- 7 Hose

- 8 Hose fittings
- 9 Hose fittings
- 10 Nozzle
- 11 Flow meter connection
- 12 Flow meter
- 13 Reducing piece
- 14 Discharge spout

- 15 Wall bracket
- 16 Equipotential bonding cable
- 17 Emission proof drum adapter
- 18 Drum adapter
- 19 Installation flange
- 20 Clamping device
- 21 Foot strainer
- 22 level switch

description ▼ data ▼ order-no. ▼

description ▼	data ▼	order-no. ▼	
Hose connector with wing nut for connecting the hoses to the drum pump	PP	ND 19	825-0005
		ND 25	825-0006
		ND 32	825-0007
	PVDF	ND 19	825-0008
		ND 25	825-0009
		ND 32	825-0010
	stainless steel	ND 19	825-0011
		ND 25	825-0012
		ND 32	825-0013
	HC	ND 19	on demand
		ND 25	825-0015
		ND 32	on demand



Hose fittings for linking electrically conductive hoses to ensure elimination of electrostatic charges. For mineral oil hose, solvent hose, chemical hose and chemical hose high-resistant.	stainless steel 1.4571 for hose ND 25	IT G 11/4	825-0001
		OT G 1	825-0020
		IT G 1	825-0021
	brass for hose ND 25	IT G 11/4	825-0002
		OT G 1	825-0022
		IT G 1	825-0023

IT = inner thread
OT = outer thread



Hose clamps to fix hoses at the hose connector	stainless steel	ND 19-25	825-0003
		ND 25-32	825-0004



Hoses

PVC – reinforced for aggressive, non-inflammable liquids like acids and caustics	operating pressure	ND 19	820-0001
	max. 10 bar	ND 25	820-0002
		ND 32	820-0003
PVC – clear, oil resistant for mineral oils	operating pressure	ND 19	820-0028
	max. 3 bar	ND 25	820-0027
		ND 32	820-0029
Mineral oil hose NBR liner, electrically conductive, for petrol, diesel oil, fuel oil and petroleum	operating pressure	ND 19	820-0010
	max. 10 bar	ND 25	820-0011
		ND 32	820-0012
Solvent hose EPDM liner, electrically conductive, for alcohols, benzene, toluene, acetone, glycols, softener oils, acids, caustics etc.	operating pressure	ND 19	820-0004
	max. 16 bar	ND 25	820-0005
		ND 32	820-0006
Chemical hose PE-X liner, electrically conductive, for approx. 95% of all industrial chemicals	operating pressure	ND 19	820-0007
	max. 16 bar	ND 25	820-0008
		ND 32	820-0009
Chemical hose high resistant FEP-liner, electrically conductive, for high-aggressive acids and caustics and nearly all liquids	operating pressure	ND 19	820-0015
	max. 16 bar	ND 25	820-0016
		ND 32	820-0017

D

Accessories

description ▼

data ▼

order-no. ▼

Nozzles**PP**

for neutral and aggressive liquids
like acids, caustics etc.,
housing: polypropylene,
seals: FPM,
other seals on request
PP / FPM / stainless steel
PP / FPM / hastelloy C

connection: hose liner ND 25
operating pressure: max. 3 bar
temperature: max. 50 °C
viscosity: max. 750 mPas
flow rate: max. 50 l/min

830-0038

830-0055

**PVDF**

for highly-aggressive liquids,
housing: polyvinylidene fluoride,
seals: FPM,
other seals on request

connection: outer thread G 1 1/4
operating pressure: max. 3 bar
temperature: max. 50 °C
viscosity: max. 750 mPas
flow rate: max. 50 l/min

830-0029

**SS**

for solvents etc.,
housing: stainless steel,
seals: FPM,
other seals on request

connection: outer thread G 1 1/4
operating pressure: max. 3 bar
temperature: max. 70 °C
viscosity: max. 750 mPas
flow rate: max. 50 l/min

830-0030

**Aluminium**

for oils and neutral liquids,
housing: aluminium,
seals: NBR

connection: hose liner ND 19
hose liner ND 25
operating pressure: max. 3 bar
temperature: max. 60 °C
viscosity: max. 750 mPas
flow rate: max. 60 l/min

830-0042

830-0043

Brass

for solvents etc.,
housing: brass, nickel plated
seals: PTFE

connection: inner thread G 1 1/4
hose liner ND 19
hose liner ND 25
hose liner ND 32
operating pressure: max. 4 bar
temperature: max. 80 °C
viscosity: max. 750 mPas
flow rate: max. 80 l/min

830-0037

830-0014

830-0003

830-0004

**Necessary accessories for explosion-proof barrel pumps****Explosion-proof plug**

round plug
EEx de IIC T6
splash proof IP 65

BBC system	3-pole	815-0009
	5-pole	815-0011
STAHL system	3-pole	815-0001
	5-pole	815-0002

**Explosion-proof socket**

socket
EEx de IIC T6
splash proof IP 65

BBC system	3-pole	815-0010
	5-pole	815-0012
STAHL system	3-pole	815-0003
	5-pole	815-0004



description ▼	data ▼	order-no. ▼
Equipotential bonding cable for electrically conductive connection between pump and drum or container, prevent electrostatic charges	1,5 m with clips	815-0005
Foot strainer to protect drum pump for coarse impurities	PP, ø 40 mm stainless steel, ø 40 mm	840-0002 840-0003
Wall bracket for safe keeping of drum pumps	steel varnished	840-0004
Barrel adapter for fixing a drum pump in the barrel opening	PP, ø 40 mm, outer thread G 2 SS, ø 40 mm, outer thread G 2	840-0006 840-0005
Clamping device to fix a drum pump in an opentopped barrel or container	stainless steel, for pump tube ø 40 mm	840-0008
Discharge spout with wing nut connection thread G 11/4	stainless steel	840-0022
Installation flange for fixing drum pumps ND 50, NP 6	PP PVDF stainless steel HC	840-0009 840-0011 840-0013 840-0015
Connecting flange for flanging on to piping ND 32, NP 6	PP PVDF stainless steel	840-0010 840-0012 840-0014
Maintenance unit for compressed air motors to clean and oil the supply air	operation pressure max. 10 bar	850-0001
Compressed air connector	outer thread G 3/8, hose liner ND 9	850-0002
Compressed air hose	PVC-reinforced, ND 9	850-0003
level switch	tube 1000 mm other length on request	PP 840-0194 PVDF 840-0198 stainless steel 840-0192



D

Accessories

Emission proof drum adapter ESA

The emission proof drum adapter ESA, locks the pump tube in the drum opening and seals the opening around the tube. ESA prevents gas from leaking out of the drum opening into the environment. To avoid a vacuum, generated when pumping the liquid out of the drum, ESA has a valve, which allows air outside to enter the drum when a low pressure is created. If no liquid is pumped from the drum, then the valve remains closed and keep the gas inside the drum. ESA is available in different materials for all pump tubes with tube diameter 40 mm.

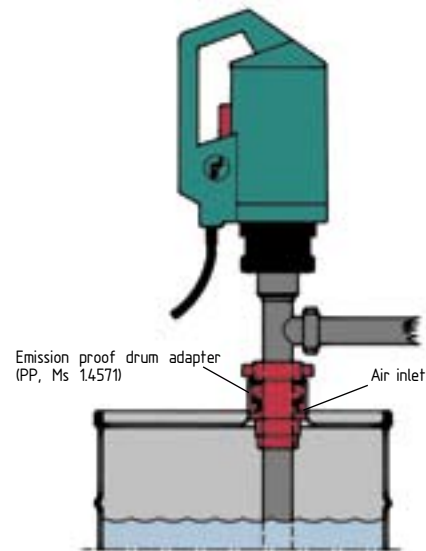

Emission proof drum adapter

for drum opening G 2 and
pump tube \varnothing 40 mm

PP
brass
stainless steel

840-0095
840-0096
840-0097

Gas displacement system GPA

The drum adapter with gas displacement system GPA secures the pump tube in the drum opening and also seals the opening around the pump tube. The GPA allows the exchange of gas via a small hose between the container to be emptied and the container to be filled. The gas volume displaced by filling the container may flow back into the container where the liquid is pumped out. With the GPA it is possible to create a closed circulation system which prevents any flammable gas from escaping into the environment. GPA is available in different materials for all pump tubes with 40 mm tube diameter.

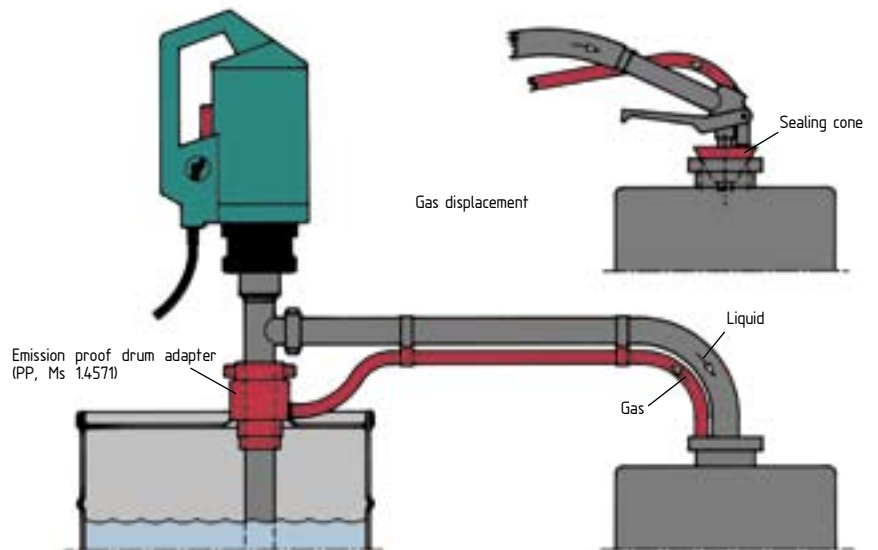

Gas displacement barrel adapter

for drum opening G 2 with hose liner ND 9
for gas displacement hose

PP
brass
stainless steel

840-0098
840-0099
840-0100

Emission proof sealing cone

PP
PTFE electrically conductive

840-0101
840-0102

Gas displacement hose ND 9

PVC-reinforced

850-0003

Solvent hose for gas displacement ND 9

NBR liner, conductive

820-0014

Gas displacement nozzle

outlet tube \varnothing 20 mm

PP, with hose liner ND 25
SS, with outer thread G 1

830-0031
830-0032

Flow meter

Flow meter electronic FM

The flow meter type FM is used to measure the volume of thin, low viscosity liquids. It can be mounted onto a drum pump or integrated into the pipeline.

The measuring principle is based on a radial turbine impeller. Because of the very low pressure losses it can be used with a very low pre-pressure. The pressure created when emptying a container is sufficient.

The measured value is transmitted sealless and contactless through magnets, so that there is a leakage-free separation between the wet and the dry area.

The conversion of the measured value is done through an electronic part with a display on it. Power is provided by extra long life lithium-batteries (service life 5 years).

The display is clear and readable and has two lines. The first big line (12 mm figures,

6-digit) shows the topical datas in litre. The second smaller line (6 mm figures, 6-digit) shows the total volume or a user-orientated partial-sum.

The clear foil-keyboard is easy to handle.

The display housing can be rotated in 90° steps.

Easy calibration regarding to the liquid.

For processing of measured values the flow meter can be fitted with an impulse-adapt-er.

For different liquids there are different materials.



POM

for diesel oil, fuel oil, anti-freeze and other neutral liquids

PP

for acids and caustics

PVDF

for highly aggressive acids, caustics and solvents

OPERATING DATA FLOW METER

Type		FM - POM	FM - PP	FM - PVDF
measuring principle		radial turbine impeller		
material:	housing	POM	PP	PVDF
	turbine	POM	PP	PVDF
	shaft	SS	HC	HC
	seal	NBR	FPM	FPM
flow range		20 – 125 l/min		
viscosity		max 20 mPas		
accuracy		±1 %		
operating pressure		max. 2 bar		
burst pressure		10 bar	4 bar	4 bar
temperature		-10 to +40 °C		
connection		outer thread G 1		
weight		0,3 kg		
order-no.		860-0007	860-0008	860-0009

POM = Polyoxymethylene
 PP = Polypropylene
 PVDF = Polyvinylidene fluoride
 HC = Hastelloy C-4
 NBR = Perbunan
 FPM = fluorine rubber
 SS = stainless steel 1.4571

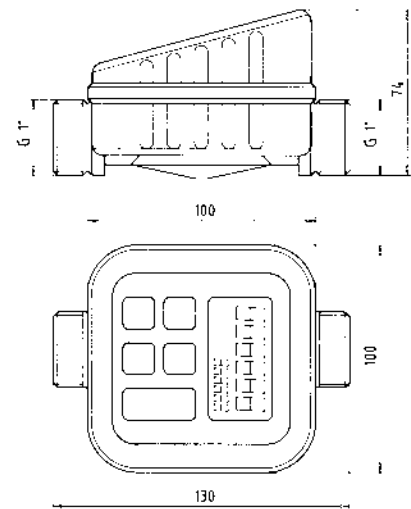

D

Accessories/
Flow meter

OPERATING DATA CONNECTION PIECES FOR FLOW METER

description	flow meter	connecting thread	material	order-no.
flow meter connection onto the drum pump (inlet)	FM-PP	inner thread	PP	825-0048
	FM-PVDF	G 1 1/4 - G 1	PVDF, FPM	825-0066
reducing piece (outlet)	FM-PP	inner thread G 1 -	PP	825-0068
	FM-PVDF	outer thread G 1 1/4	PVDF, FPM	825-0069

Flow meter

Flow meter electronic EDM
Explosion-proof EEx ia IIC T6

The flow meter type EDM is used to measure the volume of thin, low viscosity and also inflammable liquids. It is mainly designed to integrate into a pipeline or hoseline.

The measuring principle is based on an axial turbine impeller. Because of the very low pressure losses it can be used with a very low pre-pressure.

The measured value is transmitted sealless and contactless through magnets, so that there is a leakage-free separation between the wet and the dry area.

The conversion of the measured value is done through an electronic part with a display on it. Power is provided by extra long life lithium power cells (service life up to 4.000 hours).

Nylon

for neutral liquids

The display shows a resetable batch total and a non-resetable cumulative total.

Easy calibration regarding to the liquid.

For processing of measured values the flow meter can be fitted with an impulse-adapter.

For different liquids there are different materials.

Stainless steel (SS)

for aggressive liquids

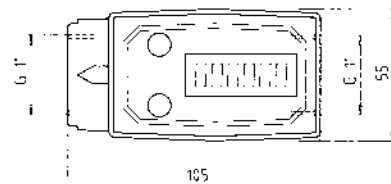
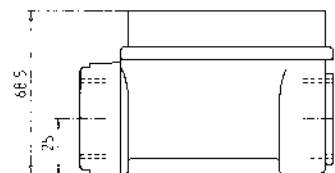

type	EDM-Nylon	EDM-SS
measuring principle	axial turbine impeller	axial turbine impeller
material:	<ul style="list-style-type: none"> • housing Nylon • turbine Nylon • bearing ceramic • shaft tungsten carbide • magnet ferrit 	<ul style="list-style-type: none"> stainless steel PVDF ceramic tungsten carbide PVDF covered
flow range	10 – 190 l/min	10 – 190 l/min
viscosity	max 2000 mPas	
accuracy	±1 %	±1 %
operation pressure	10 bar	50 bar
temperature	-10 to +60 °C	-10 to +60 °C
connection	inner thread G 1	inner thread G 1
protection class	—	EEx ia IIC T6
weight	0,3 kg	1,0 kg
order-no.	860-0003	860-0006

Questionnaire for our offer

1. Medium

- 1.1 Type _____ chemical formula _____
- 1.2 Concentration _____ %
- 1.3 Density _____ g/cm³
- 1.4 Viscosity _____ mPas/cP at _____ °C
- 1.5 Operating temperature _____ °C
- 1.6 Suspended solids _____ g/l hard soft particle size _____ mm
- 1.7 Does the medium tend to crystalize? yes no at _____ °C
- 1.8 Which materials according to your experience are resistant against the medium (tubes, fittings)? _____

2. Operating conditions

- 2.1 Capacity flow _____ m³/h or l/min
- 2.2 Delivery head (including pipework resistance) _____ m wc
- 2.3 Operating conditions? portable permanent vertical horizontal
- 2.4 Immersion depth _____ mm flange yes no
- 2.5 Drum bung hole diameter _____ mm
- 2.6 Strainer yes no
- 2.7 Operating hours per day _____ closing frequency _____

3. Motor

- 3.1 AC DC three phase current compressed air
- 3.2.1 Voltage _____ Volt / Frequency _____ Hz
- 3.2.2 Pressure _____ bar
- 3.3 Flame proof required? yes no
- Class of hazard: _____ Protection: _____
- Special requirements: _____

4. Offer to

- Company: _____
- Address: _____
- Telephone: _____ Telefax: _____
- Date: _____ Signature: _____



Distributor :



ХЕНЛИХ ООД

Индустриална техника

HENNLICH

+ коректна консултация!

4003 Пловдив
ул. Брезовско шосе 147А, ет. 3
тел./факс 032 621 929
office@hennlich.bg
www.hennlich.bg

grün-pumpen gmbh

Otto-Schott Str. 19

D-97877 Wertheim

Telefon +49 93 42 9 35 16-0

Telefax +49 93 42 9 35 16- 29

info@gruen-pumpen.de

www.gruen-pumpen.de

Handelsregister:

Reg. Gericht Mannheim

HRB 570326

Sitz der Gesellschaft :

Wertheim

Geschäftsführer :

Ralph Dostmann ,

Dr. Thomas Sigel

USt.IdNr. DE 160765854

grün-pumpen
take out, what's in.

