

Wear resistant submersible drainage pumps for clear water and drainage water.

H 82, H 16

Application

HOMA H 82 and H 16 are wear resistant submersible drainage pumps. With their 10 mm spherical clearance they are the ideal solution to pump clear water or drainage water with abrasive sand or mud additives. They are used to pump surface water from sumps, subways and building sites, supply of industrial water, application on board ships etc.

DIN EN 12050-2: Conformity and design approved and controlled by LGA, certificate No. 0220119.

Institute of Building Technology, Berlin.

Installation: Transportable or permanent. Models with float switch control for automatic pump operation, depending on liquid level in the sump.

Pumped liquid: Clear water or drainage water containing soft solids up to 10 mm spherical clearance.

Max. liquid temperature: 35° C, short term up to 60° C.

Design

Fully submersible, compact integrated motor-pump unit consisting of:

Pump: Single stage centrifugal pump with horizontal discharge BSP 1½" F.

Impeller: Open multi-channel impeller, spherical clearance 10 mm.

Motor: Fully submersible, pressure tight electric motor, oil-filled. Insulation class B. Motor protection IP 68. Cable connection chamber totally isolated from motor housing.

Cable: H 07 RN-F 4 G 1,5

Model W: H 07 RN-F 3 G 1

Cable length: 10 m.

Shaft/Bearing: Large diameter stainless steel rotor shaft, pre-lubricated bearings.

Seals: Triple lip-seal combination.

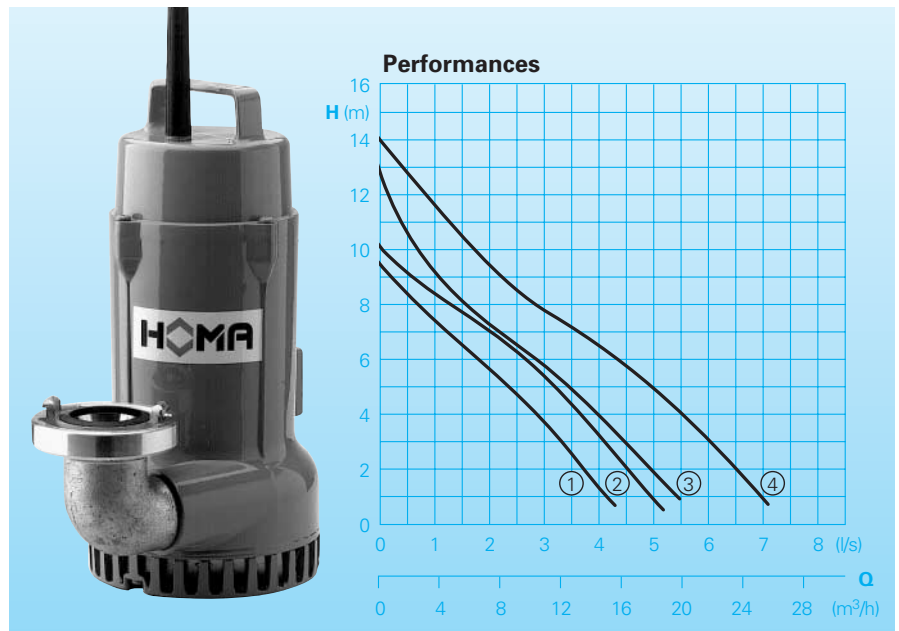

Technical Data

Curve No.	Pump type	Motor-input P ₁ (kW)	Motor-output P ₂ (kW)	Voltage 50 Hz (V)	Speed (rpm)	Nominal current (A)	Weight (kg)
①	H 82 W (A)	0,65	0,5	230-240/1Ph	2900	4,0	11
②	H 82 D (A)	0,65	0,5	400-415/3Ph	2900	1,7	11
③	H 16 W (A)	0,85	0,6	230-240/1Ph	2900	6,0	14
④	H 16 D (A)	1,1	0,9	400-415/3Ph	2900	2,7	14

Discharge: BSP 1½" F

Model A: With automatic level control HOMA-Nivomatik

Materials:

Motor housing, motor housing cover, motor bearing housing, suction sieve	Aluminium
Suction cover	Aluminium rubberized
Impeller	Cast iron GG/EN-GJL-250
Rotor shaft, screws	Stainless steel
Seal kit	Perbonane

Equipment supplied

Pump with 90° elbow and STORZ-fixed coupling, size C.

Model W (230-240V/1Ph): Supplied with control box W01 fitted with overload protection, on-off-switch, 10 m of cable and plug.

Model D (400-415V/3Ph): Supplied with control box D32 fitted with overload protection, on-off-switch, 10 m of cable and phase inverter.

Model A: With additional automatic level control, control box WA/01; DA10/32, AS-float switch, manual-auto-switch and 10 m of cable.

Dimensions and Installations

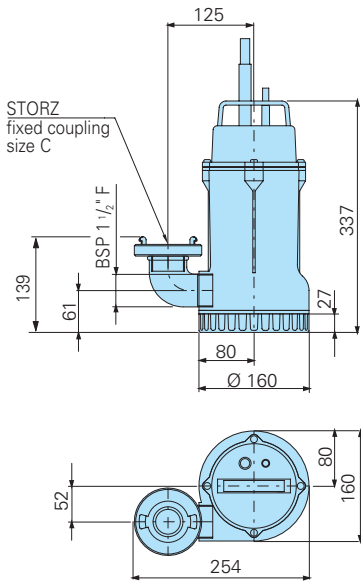

all dimensions in mm

Permanent sump installation with pipework, level control and control box.

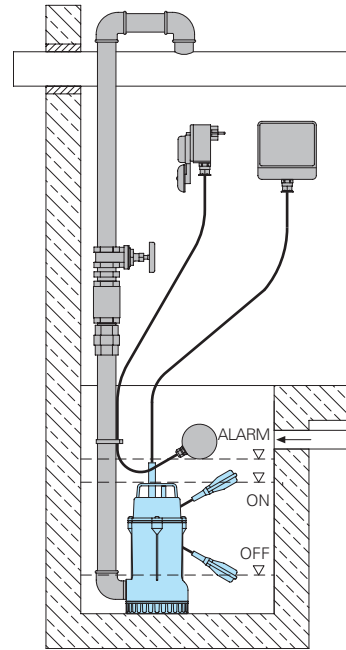

Accessories

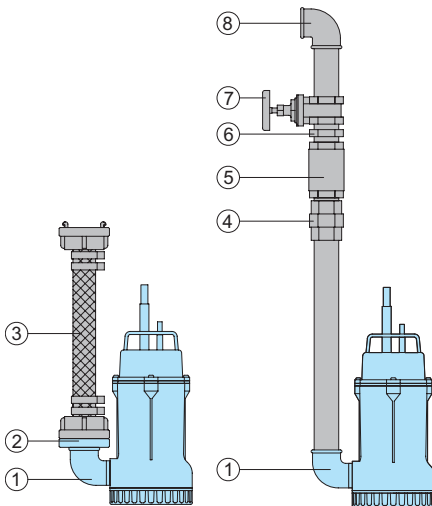

Part Description	Dimension	Part No.
① 90° galvanized elbow	BSP 1 1/2" F/M	Equipment supplied
② STORZ-fixed coupling	C-BSP 1 1/2" M	Equipment supplied
③ PVC-hose, per m	1 1/2" dia.	2621500
Reinforced hose, per m	38 mm dia.	2632038
	50 mm dia.	2632050
STORZ-hose coupling with spigot	C-38 dia.	2013002
	C-50 dia.	2013003
Synthetic pressure hose with rubber lining and couplings	10 m	2611310
	15 m	2611315
	20 m	2611320
	30 m	2611330
Hose band	1 1/2"	2304854
	2"	2306009
④ Galvanized pipe union	BSP 1 1/2" M/F	2114305
⑤ Bronze non-return valve	BSP 1 1/2" F	2211313
⑥ Galvanized double nipple	BSP 1 1/2" M	2009020
⑦ Bronze gate valve	BSP 1 1/2" F	2216015
⑧ 90° galvanized elbow	BSP 1 1/2" F	2113605
T-piece for twin-pump arrangement	BSP 1 1/2" F	2114302

Part Description	Dimension	Part No.
○ HOMA-Nivomatik float switch level control conversion kit		On request
○ HOMA 2 poles earth leakage circuit breaker Fi 16/0,03 A		1561160
○ Control panel for single or twin pump station for automatic operation		On request

HOMA
P U M P T E C H N O L O G Y

HOMA Pumpenfabrik GmbH
Postfach 22 63, D-53814 Neunk.-Seelscheid
Tel. +49(0)22 47/702-0, Fax +49(0)22 47/702-44
e-mail: info@homa-pumpen.de
www.homapumps.com