

Stainless steel submersible drainage pumps for chemically aggressive liquids. Spherical clearance 50 – 70 mm.

CTP 50, CTP 53, CTP 70

Application

HOMA CTP stainless steel submersible drainage pumps are suitable for pumping corrosive, abrasive or chemically aggressive liquids, waste water or sewage and chemicals containing soft solids of 50 - 70 mm diameter. They are used in various domestic, industrial or municipal applications.

DIN EN 12050-2: Conformity and design approved and controlled by LGA, certificate No. 0220119.

Installation: Transportable or permanent.

Pumped liquid: Drainage water or sewage containing soft solids and chemically aggressive liquids.

Max. liquid temperature: 40°C, short term up to 60°C.

Operation: Permanent (S1).

Design

Fully submersible, compact integrated motor-pump unit consisting of:

Pump: Single stage centrifugal pump with horizontal discharge.

Impeller: Closed single channel impeller for liquids containing impurities and sludge with solid particles. Spherical clearance 50 and 70 mm.

Motor: Fully submersible, pressure tight electric motor. Insulation class F. Degree of protection IP 68. Thermal sensor embedded in the winding. Cable: H07 RN-F (Plus) 6G1,5 with cable protective hose and longitudinally tight cable trumpet. Explosion proof motors according to \odot II G EEX d II BT4.

Shaft/Bearing: Large diameter stainless steel rotor shaft, pre-lubricated bearings.

Seals: Combination of two mechanical seals (silicon-carbide/ silicon-carbide) in separate oil chamber. Oil inspection from outside.

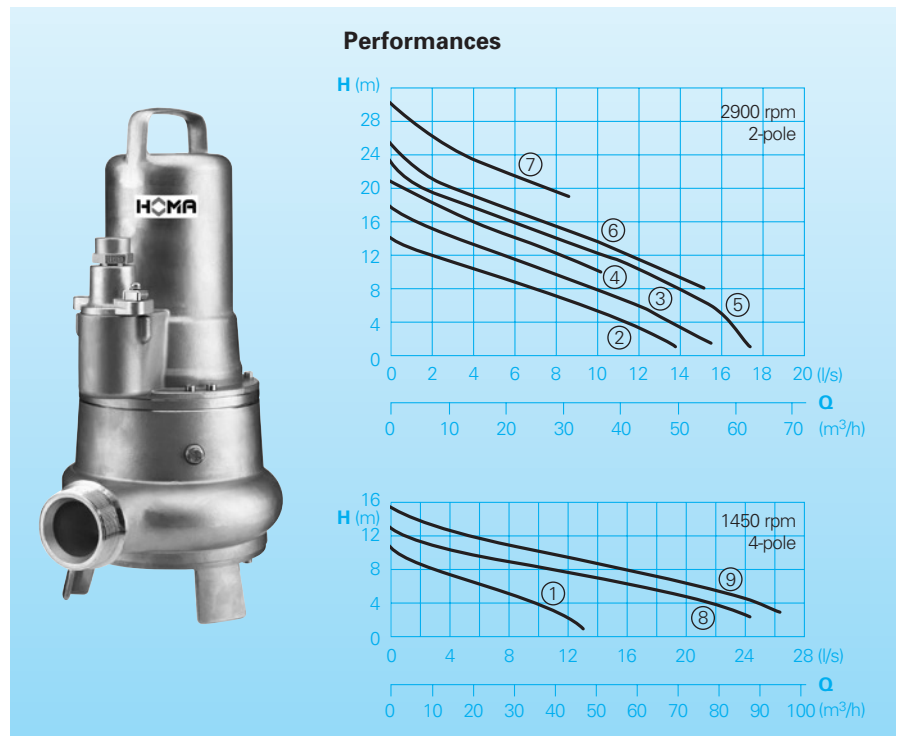

Technical Data

Curve No.	Pump type	Motor input P ₁ (kW)	Motor output P ₂ (kW)	Speed (rpm)	Nominal current (A)	Spherical clearance (mm)	Discharge	Weight (kg)
①	CTP 50 (53) M 13/4 D (Ex)	1,3	1,0	1450	2,6	50	BSP2 1/2" (3") M	39
②	CTP 50 (53) M 19/2 D (Ex)	1,9	1,5	2800	4,0	50	BSP2 1/2" (3") M	39
③	CTP 50 (53) M 23/2 D (Ex)	2,3	1,8	2800	4,4	50	BSP2 1/2" (3") M	39
④	CTP 50 (53) M 24/2 D (Ex)	2,4	1,9	2800	4,6	50	BSP2 1/2" (3") M	39
⑤	CTP 50 (53) M 34/2 D (Ex)	3,4	2,8	2800	6,9	50	BSP2 1/2" (3") M	51
⑥	CTP 50 (53) M 35/2 D (Ex)	3,5	2,8	2800	7,1	50	BSP2 1/2" (3") M	51
⑦	CTP 50 (53) M 35/2 HD (Ex)	3,5	2,8	2800	7,1	50	BSP2 1/2" (3") M	51
⑧	CTP 70 M 26/4 D (Ex)	2,5	2,0	1450	5,4	70	DN 80	65
⑨	CTP 70 M 31/4 D (Ex)	3,2	2,5	1450	6,1	70	DN 80	65

Voltage: 400-415 V / 3 Ph

Model Ex: explosion proof

Materials:	
Pump housing, impeller, motor housing	Stainless steel 1.4436
Rotor shaft, wear ring mechanical connection parts	Stainless steel 1.4571
O-Rings	FPM (Viton)
Mechanical seals	SiC / SiC, FPM (Viton)
Cable protective hose	Polyolefine

Equipment supplied

Pumps with base stand, 10 m of cable, 5 m cable protective hose. Control boxes DT32; DA10/32; DA 10/12; DZ12 available as accessories.

Dimensions and Installations

CTP50M CTP53M

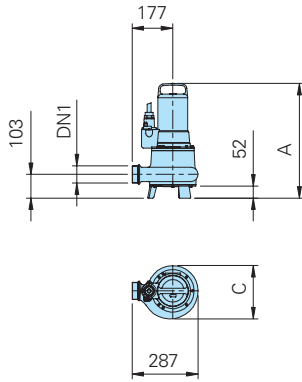

CTP70M

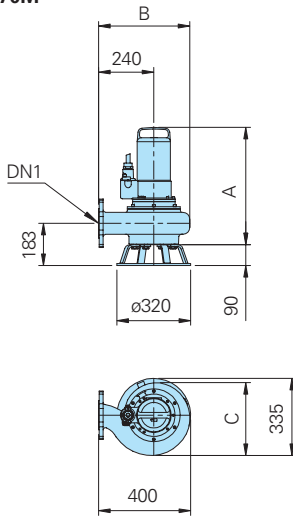

all dimensions in mm

CTP50M KKC65 / BSP 2 1/2" - VA

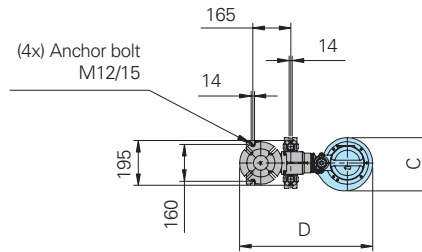
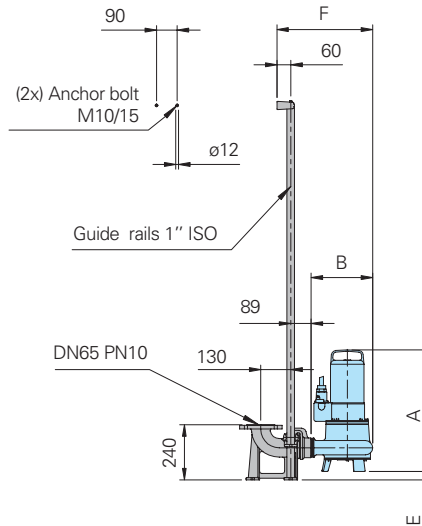

CTP53M KKC80 / BSP 3" - VA

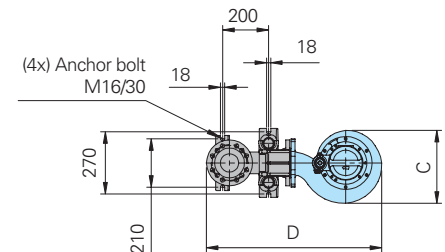
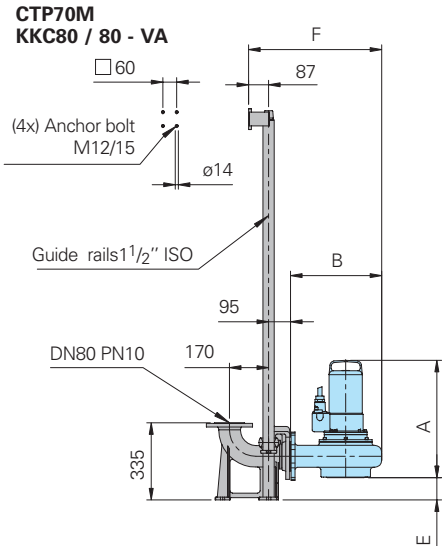

Pump type	DN1	A max	B	C	D	E	F
CTP 50 M 13/4 D (EX)	BSP 2 1/2" M	498	267	232	579	37	416
CTP 50 M (19-24)/2 D (EX)	BSP 2 1/2" M	498	267	232	579	37	416
CTP 50 M (34-35)/2 D (EX)	BSP 2 1/2" M	529	267	232	579	37	416
CTP 50 M 35/2 HD (EX)	BSP 2 1/2" M	529	267	232	579	37	416
CTP 53 M 13/4 D (EX)	BSP 3" M	498	291	232	656	87	473
CTP 53 M (19-24)/2 D (EX)	BSP 3" M	498	291	232	656	87	473
CTP 53 M (34-35)/2 D (EX)	BSP 3" M	529	291	232	656	87	473
CTP 53 M 35/2 HD (EX)	BSP 3" M	529	291	232	656	87	473
CTP 70 M (26-31)/4 D (EX)	DN80 PN10	511	397	317	762	97	579

Accessories

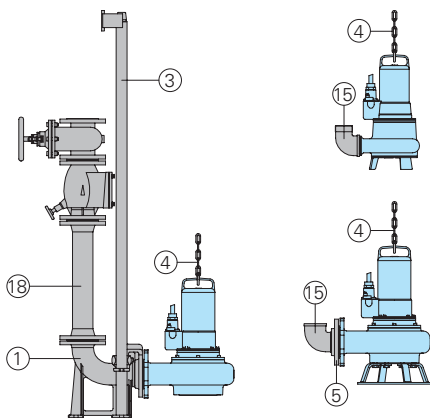

Part Description	Dimension	Part No.
① Auto-coupling system from stainless steel 1.4436, consisting of auto coupling with flange, flange pump coupling and upper slide rail bracket		
- Type KKC 65/R2 1/2"	DN 65/BSP2 1/2"	8604017
- Type KKC 80/R3"	DN 80/BSP3"	8604037
- Type KKC 80/80	DN 80	8604027
○ Auto-coupling system complete or partial in stainless steel	all types	on request
○ Screw-kits for installation of coupling system		on request
③ Guide rails, stainless steel 1.4571, dia.1" for KKC65	2190252	
dia.1 1/2" for KKC80	2190254	

Part Description	Dimension	Part No.
④ Lifting chain, stainless steel 1.4401, 5 mm dia.		2800351
per m	8 mm dia.	2800382
Shackle, for chain	5 mm dia.	2801450
stainless steel 1.4401	8 mm dia.	2801390
⑤ Threaded flange, stainless steel 1.4571	DN 65/BSP2 1/2" F	2215115
	DN 80/BSP3" F	2215120
⑬ Elbow 90°, stainless steel 1.4401	BSP2 1/2" F/M	2111826
	BSP3" F/M	2111827
⑮ Stainless steel or plastic discharge pipe and fittings		on request
○ Pump controls and control panels for permanent or transportable installation, level controllers and monitoring devices		see HOMA-accessories



HOMA Pumpenfabrik GmbH
P.O.Box 22 63, D-53814 Neunk.-Seelscheid
Tel. +49 (0) 22 47/702-0, Fax +49 (0) 22 47/702-44
e-mail: info@homa-pumpen.de
www.homapumps.com