

GEMÜ®

Ball Valve, Metal - Sanitary

Construction

GEMÜ 740, 741 and 748 are 3-piece 2/2-way metal ball valves with top flange in sizes 1/4" to 4" (DN 8 to DN 100). They are particularly suitable for sanitary/hygienic applications. The top flange enables the operators to be exchanged at any time.

GEMÜ 740 is manually operated and has a plastic sleeved hand lever.

GEMÜ 741 is operated by a low maintenance, pneumatic piston actuator in single acting (spring return) or double acting design. The actuator has a robust Alodur coated aluminium housing. An integral optical position indicator as standard.

GEMÜ 748 has a low maintenance electric actuator with a powerful DC motor. The reduction gear in the motor, consisting of a threaded spindle with a lever, provides the rotation through 90°. The actuator has an optical position indicator and a manual override as standard.

Features

- Suitable for inert, corrosive*, liquid and gaseous media and steam
- The ball valves comply with the safety requirements of Annex I of the European Pressure Equipment Directive 97/23/EC (PED) for fluids of groups 1 and 2
- Suitable for vacuum applications
- Optional ATEX version available
- Very low surface roughness - internal 0.6 µm
- Reworked welds for a minimal deadleg valve body and smooth surfaces
- Full flow bore (connection code 59 and 80)

*see information on working medium on page 3



3D - illustration

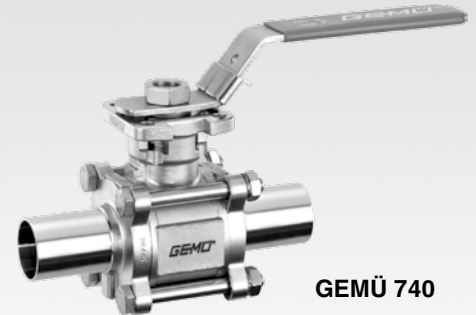

GEMÜ 740

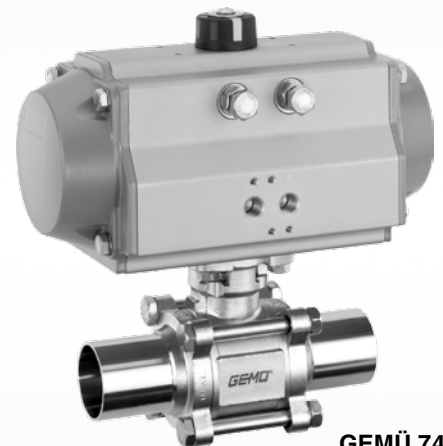

GEMÜ 741



GEMÜ 748

GEMÜ®

740, 741, 748

Product description

Specifications

Nominal sizes: 1/4" – 4"

Connection options:

- Butt weld spigots DIN 11850
- Spigots ASME BPE *
- Spigots EN ISO 1127
- Clamps ASME BPE *

See overview on page 6

Valve body material: CF3M (316L) investment casting

Ball material: CF3M (316L)

Seal material: PTFE, TFM™ (FDA compliant)

Surface finish: Internal 0.6µm polished, electropolished external

FDA compliant to FDA 21 CFR 177.1550

Max. operating pressure: 63 bar

Max. perm. operating temperature: 180°C

CIP and SIP cleaning possible.

- BSE / TSE free (body)
- Oil and grease free (body)

* with full-flow bore

Dyneon TFM* 1600 PTFE

TFM™ is a modified PTFE, also called 2nd generation PTFE. It has the same chemical and heat resistance as conventional PTFE but a considerably lower melt viscosity which leads to a much better fusion of the chips during the sintering process. Better fusion results in a smoother surface which substantially reduces the torque.

Features:

- Very smooth surface
- Reduced cold flow properties
- Very low deformation under load
- Significantly improved surface properties
- Small pore volume
- Almost universal chemical resistance

* TFM is a registered trademark of Dyneon

The spindle seal system

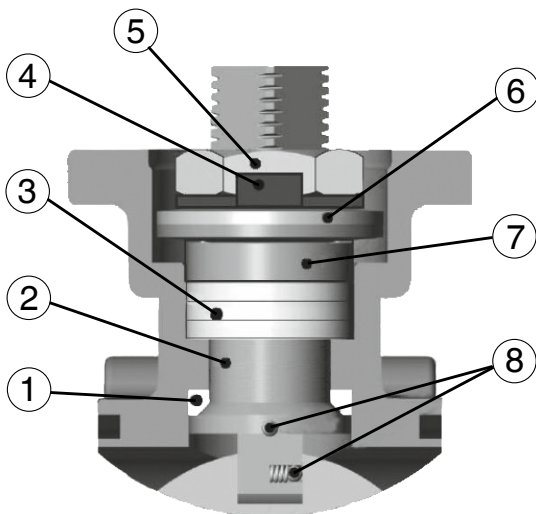

Long service life due to triple spindle seal

1. Conical spindle seal: The seal ① arranged at an angle of 45° effectively prevents the leakage of medium when operating the spindle.
2. Machined spindle surface ②: reduces the friction force of the spindle making it very smooth-running and low wear.
3. V-rings: When compressed, three V-rings expand sideways and prevent the leakage of the medium..
4. Lock washer: Prevents the loosening of the spindle nut during operation.
5. Spindle nut: fixes the entire spindle system.
6. Spring washers: compress the gland packing to prevent leakage of medium.
7. Stainless steel bush: equally distributes the force on the packing.
8. Antistatic device: between spindle/ball and spindle/body.

- | | |
|------------------------|---------------------------------|
| ① Spindle seal (PTFE) | ⑤ Spindle nut (1.4301) |
| ② Valve spindle (316L) | ⑥ Spring washers (1.4301) |
| ③ V-rings (PTFE) | ⑦ Stainless steel bush (1.4301) |
| ④ Lock washer (1.4301) | ⑧ Antistatic device (1.4401) |

Cavity filled PTFE seat 5C

The cavity filled seat made of PTFE is designed to minimise the cavity around the ball. Media remaining in the deadlegs of a valve are undesirable for example in food production. These deposits accumulate and contaminate the entire process. The cavity filled seat also enables easier cleaning of the valve.



General technical data

Working medium

Corrosive*, inert, gaseous and liquid media and steam which have no negative impact on the physical and chemical properties of the body and seal material.

Maximum permissible pressure of the working medium see diagram
(for water and non-hazardous media to which the body material is resistant)

Maximum permissible operating temperature 180 °C

Maximum permissible ambient temperature 60 °C

Control medium (only GEMÜ 741)

Control pressure 6 - 8 bar

Max. perm. temperature of control medium 60 °C

| DN | NPS | Torque* [Nm] | | Kv values [m³/h] | Weight [kg] | |
|-----|--------|---------------|---------------|---------------------|-----------------------------|------------------|
| | | Seal material | | | Ball valve without operator | |
| | | TFM™, Code 5T | PTFE, Code 5C | | Clamps ASME BPE | Spigots ASME BPE |
| 10 | 3/8" | 7 | 8 | 7.0 | - | 0.63 |
| 15 | 1/2" | 9 | 10 | 12.0 | 0.76 | 0.71 |
| 20 | 3/4" | 10 | 12 | 38.6 | 0.87 | 0.91 |
| 25 | 1" | 16 | 17 | 69.5 | 1.44 | 1.26 |
| 40 | 1 1/2" | 36 | 40 | 184.5 | 3.29 | 3.24 |
| 50 | 2" | 44 | 48 | 351.8 | 4.57 | 3.59 |
| 65 | 2 1/2" | 91 | 98 | 560.2 | 9.46 | 9.90 |
| 80 | 3" | 104 | 111 | 840.8 | 12.91 | 13.19 |
| 100 | 4" | 117 | 124 | 1578.7 | 20.33 | 21.13 |

* incl. 30% safety margin

Pressure-temperature diagram

Spigots ASME BPE

according to pipe class of the welding ends
(housing pressure max. 63 bar)

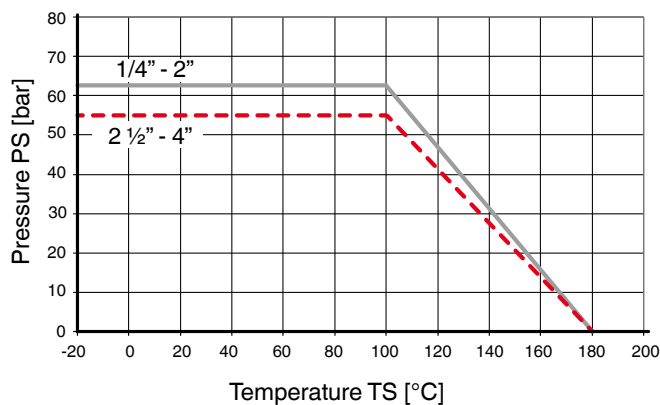

Clamps ASME BPE

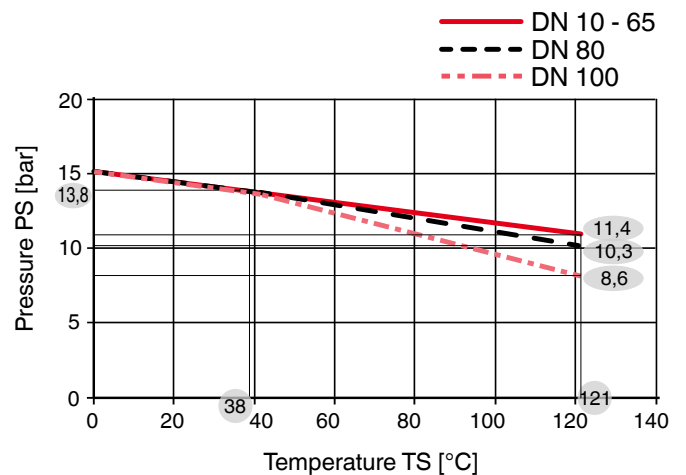

Order data - GEMÜ 740 - manually operated

| 1 Type | Code |
|----------------------------|------|
| Ball valve with hand lever | 740 |

| 2 Nominal size | Code |
|---|------|
| DN 8 1/4" (only connection code 60) | 8 |
| DN 10 3/8" (only connection code 17, 60) | 10 |
| DN 15 1/2" | 15 |
| DN 20 3/4" | 20 |
| DN 25 1" | 25 |
| DN 32 1 1/4" (not connection code 59, 80) | 32 |
| DN 40 1 1/2" | 40 |
| DN 50 2" | 50 |
| DN 65 2 1/2" | 65 |
| DN 80 3" | 80 |
| DN 100 4" | 100 |

| 3 Body configuration | Code |
|------------------------------|------|
| Straight through (2/2-way) | D |
| Multi-port design on request | |

| 4 Connection | Code |
|---------------------------------------|------|
| Butt weld spigots DIN 11850, series 2 | 17 |
| Spigots ASME BPE | 59 |
| Spigots EN ISO 1127 | 60 |
| Clamps ASME BPE | 80 |

| 5 Valve body material | Code |
|--|------|
| CF3M (316L), body (investment cast), Ball (316L) | C1 |

| 6 Seat material | Code |
|--|------|
| TFM™ (modified PTFE, FDA compliant) up to max. 180°C (also for steam up to max. 8 bar) | 5T |
| PTFE, (FDA-compliant) cavity filled seat | 5C |

| 7 Control function | Code |
|--|------|
| Manually operated with lockable hand lever | L |

| 8 Special version | Code |
|-------------------|------|
| ATEX | X |

| Order example | 1 | 2 | 3 | 4 | 5 | 6 | 7 | 8 |
|---------------|-----|----|---|----|----|----|---|---|
| | 740 | 15 | D | 60 | C1 | 5T | L | - |

Note: Wearing parts kit - order code: SP.K740-DN... (dependent on nominal size) contains replacement parts for the spindle seal and seat: Conical spindle seal (PTFE), V-ring spindle packing (PTFE), seat and flange seals (PTFE)

Body dimensions [mm]

| All versions | | | | | | | | | | | GEMÜ 740 | | |
|--------------|--------|------------|----|------|-----|-------|----|-------|------|--------|------------|-----|----|
| DN | INCH | Top flange | | | | | | | | | Hand lever | | |
| DIN | ASME | F1 | | | F2 | | | SW | H | h ±0,5 | T | A | Ct |
| 8 | 1/4" | F03 | 36 | Ø6x4 | F04 | Ø6x4 | 9 | 42.1 | 6.4 | 5 | 139 | 77 | |
| 10 | 3/8" | F03 | 36 | Ø6x4 | F04 | Ø6x4 | 9 | 42.1 | 6.4 | 5 | 139 | 77 | |
| 15 | 1/2" | F03 | 36 | Ø6x4 | F04 | Ø6x4 | 9 | 42.1 | 6.4 | 5 | 139 | 77 | |
| 20 | 3/4" | F03 | 36 | Ø6x4 | F04 | Ø6x4 | 9 | 48.0 | 6.9 | 5 | 139 | 83 | |
| 25 | 1" | F04 | 42 | Ø6x4 | F05 | Ø7x4 | 11 | 56.6 | 11.2 | 7 | 165 | 96 | |
| 32 | 1 1/4" | F04 | 42 | Ø6x4 | F05 | Ø7x4 | 11 | 60.9 | 11.2 | 7 | 165 | 100 | |
| 40 | 1 1/2" | F05 | 50 | Ø7x4 | F07 | Ø9x4 | 14 | 77.5 | 14.2 | 10 | 215 | 127 | |
| 50 | 2" | F05 | 50 | Ø7x4 | F07 | Ø9x4 | 14 | 85.2 | 14.2 | 10 | 215 | 134 | |
| 65 | 2 1/2" | F07 | 70 | Ø9x4 | F10 | Ø11x4 | 17 | 108.7 | 17.1 | 10 | 300 | 167 | |
| 80 | 3" | F07 | 70 | Ø9x4 | F10 | Ø11x4 | 17 | 117.7 | 18.1 | 10 | 370 | 176 | |
| 100 | 4" | F07 | 70 | Ø9x4 | F10 | Ø11x4 | 17 | 132.6 | 17.1 | 10 | 370 | 192 | |

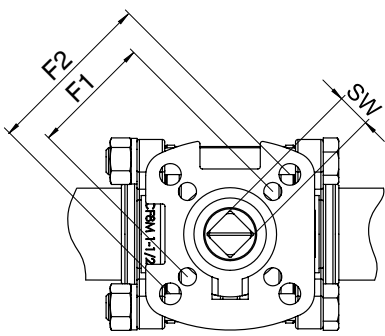

Top flange

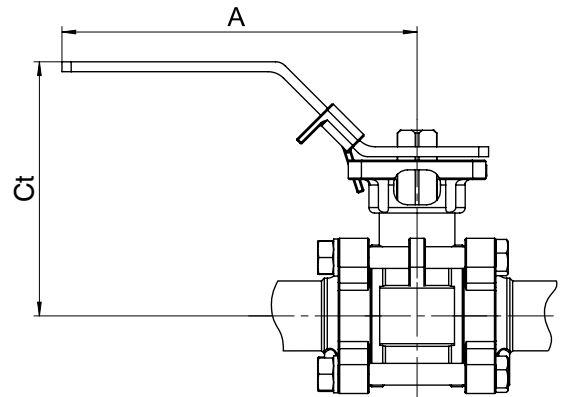
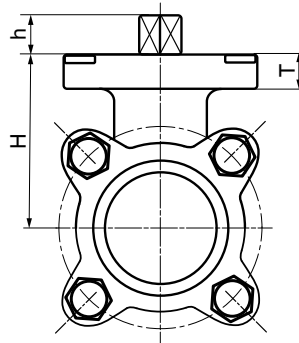

GEMÜ 740 Hand lever

| | | Spigots | | | | | | | | | | |
|-----|--------|------------------------------|------|-----|-----|-----|---------------|------|-------|-----|-------|-------|
| DN | INCH | DIN 11850 series 2 (Code 17) | | | | | ISO (Code 60) | | | | | L |
| DIN | ASME | L | LS | øD | S | ød | L | LS | øD | S | ød | |
| 8 | 1/4" | - | - | - | - | - | 120.2 | 48.3 | 13.5 | 1.6 | 10.3 | 23.6 |
| 10 | 3/8" | 120.2 | 48.2 | 13 | 1.5 | 10 | 120.2 | 48.3 | 17.2 | 1.6 | 12.7 | 23.6 |
| 15 | 1/2" | 140.2 | 58.3 | 19 | 1.5 | 15 | 140.2 | 58.3 | 21.3 | 1.6 | 15.0 | 23.6 |
| 20 | 3/4" | 140.0 | 56.0 | 23 | 1.5 | 20 | 140.0 | 56.0 | 26.9 | 1.6 | 20.0 | 28.0 |
| 25 | 1" | 152.2 | 59.2 | 29 | 1.5 | 25 | 152.2 | 59.2 | 33.7 | 2.0 | 25.0 | 33.9 |
| 32 | 1 1/4" | 165.1 | 61.3 | 35 | 1.5 | 32 | 165.1 | 61.3 | 42.4 | 2.0 | 32.0 | 42.5 |
| 40 | 1 1/2" | 190.4 | 68.6 | 41 | 1.5 | 38 | 190.4 | 68.6 | 48.3 | 2.0 | 38.0 | 53.2 |
| 50 | 2" | 203.0 | 69.2 | 53 | 1.5 | 50 | 203.0 | 69.2 | 60.3 | 2.0 | 50.0 | 64.6 |
| 65 | 2 1/2" | 254.0 | 83.5 | 70 | 2.0 | 65 | 254.0 | 83.5 | 76.1 | 2.0 | 65.0 | 87.0 |
| 80 | 3" | 280.2 | 90.6 | 85 | 2.0 | 80 | 280.2 | 90.6 | 88.9 | 2.3 | 80.0 | 99.0 |
| 100 | 4" | 317.0 | 95.0 | 104 | 2.0 | 100 | 317.0 | 95.0 | 114.3 | 2.3 | 100.0 | 127.0 |

Butt weld spigots code 17

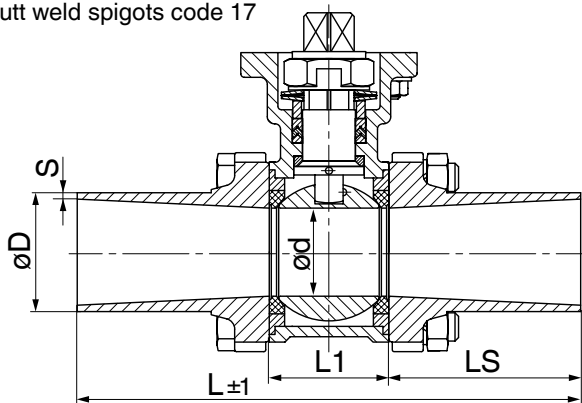

Spigots ISO code 60

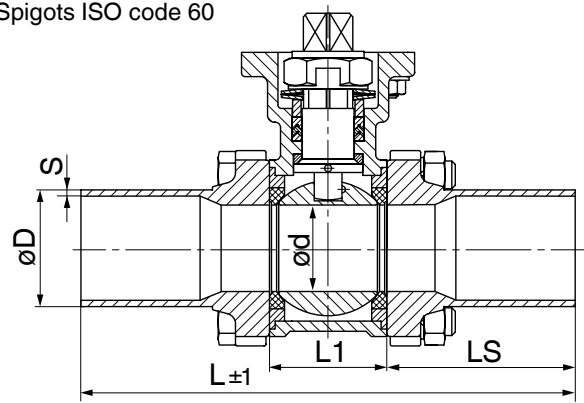

Body dimensions [mm]

| | | Spigots | | | | | Clamp | | | | |
|-----|--------|--------------------|------|-------|-----|------|--------------------|------|-------|-----|------|
| DN | INCH | ASME BPE (code 59) | | | | | ASME BPE (code 80) | | | | |
| DIN | ASME | L | LS | øD | S | ød | L | LS | øD | S | ød |
| 15 | 1/2" | 139.8 | 58.1 | 12.7 | 3.2 | 9.4 | 89.1 | 32.8 | 25.2 | 3.2 | 9.4 |
| 20 | 3/4" | 146.0 | 59.0 | 19.0 | 3.2 | 15.8 | 101.6 | 36.8 | 25.2 | 3.2 | 15.8 |
| 25 | 1" | 158.7 | 62.4 | 25.4 | 3.2 | 22.2 | 114.5 | 40.4 | 50.4 | 3.2 | 22.1 |
| 40 | 1 1/2" | 190.6 | 68.7 | 38.1 | 3.2 | 34.9 | 140.1 | 43.5 | 50.5 | 3.2 | 34.8 |
| 50 | 2" | 216.0 | 75.7 | 50.8 | 3.2 | 47.5 | 159.0 | 47.2 | 63.9 | 3.2 | 47.5 |
| 65 | 2 1/2" | 247.6 | 80.3 | 63.5 | 3.2 | 60.3 | 174.0 | 43.5 | 77.4 | 3.2 | 60.2 |
| 80 | 3" | 266.8 | 83.9 | 76.2 | 3.2 | 73.0 | 193.2 | 47.1 | 90.9 | 3.2 | 72.9 |
| 100 | 4" | 317.6 | 95.3 | 101.6 | 3.2 | 97.4 | 226.0 | 49.5 | 118.9 | 3.2 | 97.4 |

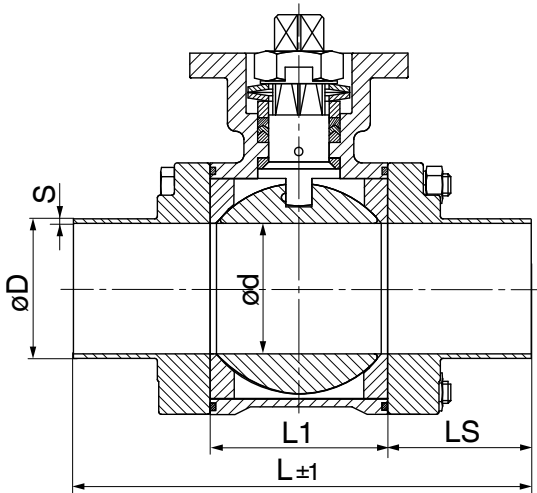

Spigots ASME code 59

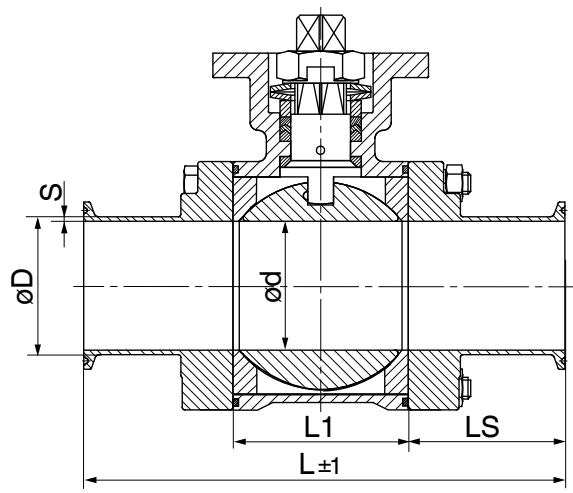

Clamps ASME BPE code 80

Overview

| DN | INCH | Spigots | | | Clamp |
|-----|--------|---------------------------|------------------|-------------|------------------|
| DIN | ASME | DIN 11850 Reihe 2 code 17 | ASME BPE code 59 | ISO code 60 | ASME BPE code 80 |
| 8 | 1/4" | - | - | X | - |
| 10 | 3/8" | X | - | X | - |
| 15 | 1/2" | X | X | X | X |
| 20 | 3/4" | X | X | X | X |
| 25 | 1" | X | X | X | X |
| 32 | 1 1/4" | X | - | X | - |
| 40 | 1 1/2" | X | X | X | X |
| 50 | 2" | X | X | X | X |
| 65 | 2 1/2" | X | X | X | X |
| 80 | 3" | X | X | X | X |
| 100 | 4" | X | X | X | X |

Order data - GEMÜ 741 - pneumatically operated

| 1 Type | Code |
|------------------------------------|------|
| Ball valve with pneumatic actuator | 741 |

| 2 Nominal size | Code |
|---|------|
| DN 8 1/4" (only connection code 60) | 8 |
| DN 10 3/8" (only connection code 17, 60) | 10 |
| DN 15 1/2" | 15 |
| DN 20 3/4" | 20 |
| DN 25 1" | 25 |
| DN 32 1 1/4" (not connection code 59, 80) | 32 |
| DN 40 1 1/2" | 40 |
| DN 50 2" | 50 |
| DN 65 2 1/2" | 65 |
| DN 80 3" | 80 |
| DN 100 4" | 100 |

| 3 Body configuration* | Code |
|--------------------------------|------|
| Straight through (2/2-way) | D |
| * Multi-port design on request | |

| 4 Connection | Code |
|---------------------------------------|------|
| Butt weld spigots DIN 11850, series 2 | 17 |
| Spigots ASME BPE | 59 |
| Spigots EN ISO 1127 | 60 |
| Clamps ASME BPE | 80 |

| 5 Valve body material | Code |
|-------------------------------------|------|
| CF3M (316L), body (investment cast) | C1 |
| CF3M (316L), ball | |

| 6 Seat material | Code |
|--|------|
| TFM™ (modified PTFE, FDA compliant) up to max. 180°C (also for steam up to max. 8 bar) | 5T |
| PTFE, (FDA-compliant) cavity filled seat | 5C |

| 7 Control function | Code |
|----------------------|------|
| Normally closed (NC) | 1 |
| Normally open (NO) | 2 |
| Double acting (DA) | 3 |

| 8 Actuator size | | Code |
|-----------------|------------------------------|---------|
| DN | Single acting SC | |
| DN 8-15 | SC0015U 8 F04NS11A | SU01KO0 |
| DN 20 | SC0030U 6 F04NS11A | SU03KO0 |
| DN 25, 32 | SC0060U 6 F05F07NS14A | SU06KP0 |
| DN 40 | SC0150U 6 F07F10NS17A | SU15KC0 |
| DN 50, 65 | SC0220U 6 F07F10NS22A | SU22KD0 |
| DN 80 | SC0300U 6 F07F10NS22A | SU30KD0 |
| DN 100 | SC0450U 6 F10F12NS27A | SU45KG0 |
| | Double acting DR | |
| DN 8-20 | DR0015U F04NS11A | DU01AO0 |
| DN 25, 32 | DR0030U F05F07NS14A | DU03AP0 |
| DN 40 | DR0060U F05F07NS17A | DU06AC0 |
| DN 50, 65 | DR0100U F05F07NS17A | DU10AC0 |
| DN 80 | DR0150U F07F10NS22A | DU15AD0 |
| DN 100 | DR0220U F07F10NS22A | DU22AD0 |
| | Single acting ASR | |
| DN 8-20 | ASR0020U S08 F04YS14/S11A | AU02FA0 |
| DN 25 | ASR0040U S14 F05YS14/S11A | AU04KB0 |
| DN 32, 40 | ASR0080U S14 F05707YS17/S11A | AU08KC0 |
| DN 50 | ASR0130U S14 F05F07YS17/S14A | AU13KC0 |
| DN 65 | ASR0200U S14 F07F10YS17/S14A | AU20KE0 |
| DN 80 | ASR0300U S14 F07F10YS22A | AU30KD0 |
| DN 100 | ASR0500U S14 F10YS22A | AU50KF0 |
| | Double acting ADA | |
| DN 8-25 | ADA0020U F04YS11A | BU02AA0 |
| DN 32, 40 | ADA0080U F05F07YS17/S14A | BU08AB0 |
| DN 50 | ADA0080U F05F07YS17/S14A | BU08AC0 |
| DN 65 | ADA0130U F05F07YS17/S14A | BU13AC0 |
| DN 80 | ADA0200U F07F10YS17/S14A | BU20AE0 |
| DN 100 | ADA0300U F07F10YS22A | BU30AD0 |

| 9 Special version | Code |
|-------------------|------|
| ATEX | X |

| 10 K number | Code |
|---|------|
| Mounting flange with adapter | 5222 |
| For operating temperatures > 100° C a mounting flange with an adapter is required between ball valve and actuator! See data sheet: -Accessories for quarter turn valves- | |

| Order example | 1 | 2 | 3 | 4 | 5 | 6 | 7 | 8 | 9 | 10 |
|---------------|-----|----|---|----|----|----|---|---------|---|----|
| | 741 | 15 | D | 59 | C1 | 5T | 1 | SU01KO0 | - | - |

Note: Wearing parts kit - order code: SPK741-DN... (dependent on nominal size) contains replacement parts for the spindle seal and seat: Conical spindle seal (PTFE), V-ring spindle packing (PTFE), seat and flange seals (PTFE)

Actuator dimensions - GEMÜ 741 - pneumatically operated

Actuator ADA/ASR [mm]

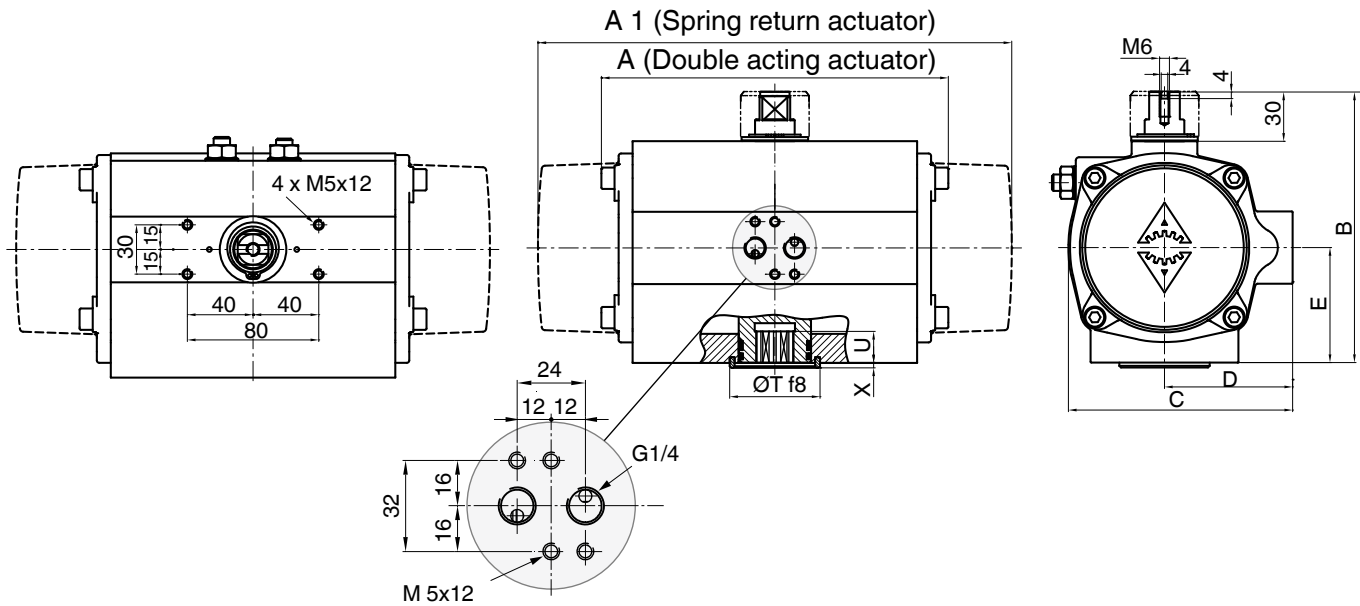

| ADA/ASR | 0020U | | 0040U | | 0080U | 0130U | 0200U | 0300U | 0500U | |
|--------------------|---------|------|-------|------|-------|-------|-------|-------|-------|------|
| | F03/F05 | F04 | F05 | F04 | F05 | F05 | F05 | F07 | F10 | |
| ISO 5211 | F03/F05 | F04 | F05 | F04 | F05 | F05 | F05 | F07 | F10 | |
| Octagonal | 9 | 14 | | 14 | | 17 | 17 | 17 | 22 | |
| Air connector | | G1/4 | | G1/4 | | G1/4 | G1/4 | G1/4 | G1/4 | |
| A | | 145 | | 158 | | 177 | 196 | 225 | 304 | |
| A1 | | 163 | | 195 | | 217 | 258 | 299 | 348,5 | |
| B | | 96 | | 115 | | 137 | 147 | 165 | 182 | |
| C | | 76 | | 91 | | 111 | 122 | 135,5 | 152,5 | |
| D | | 48 | | 56 | | 66 | 71 | 78 | 86 | |
| E | | 34 | | 45 | | 55 | 60 | 70 | 80 | |
| ØT | 25 | 35 | | 35 | | 55 | 55 | 55 | 70 | |
| U | 10 | 12 | | 12 | | 19 | 22 | 23 | 32 | |
| Weight [kg] | | | | | | | | | | |
| ADA | | 1,4 | | 2,1 | | 3,0 | 3,8 | 5,6 | 8,5 | 11,2 |
| ASR | | 1,5 | | 2,3 | | 3,7 | 4,8 | 7,3 | 10,8 | 15,4 |

Actuator dimensions - GEMÜ 741 - pneumatically operated

Actuator DR/SC [mm]

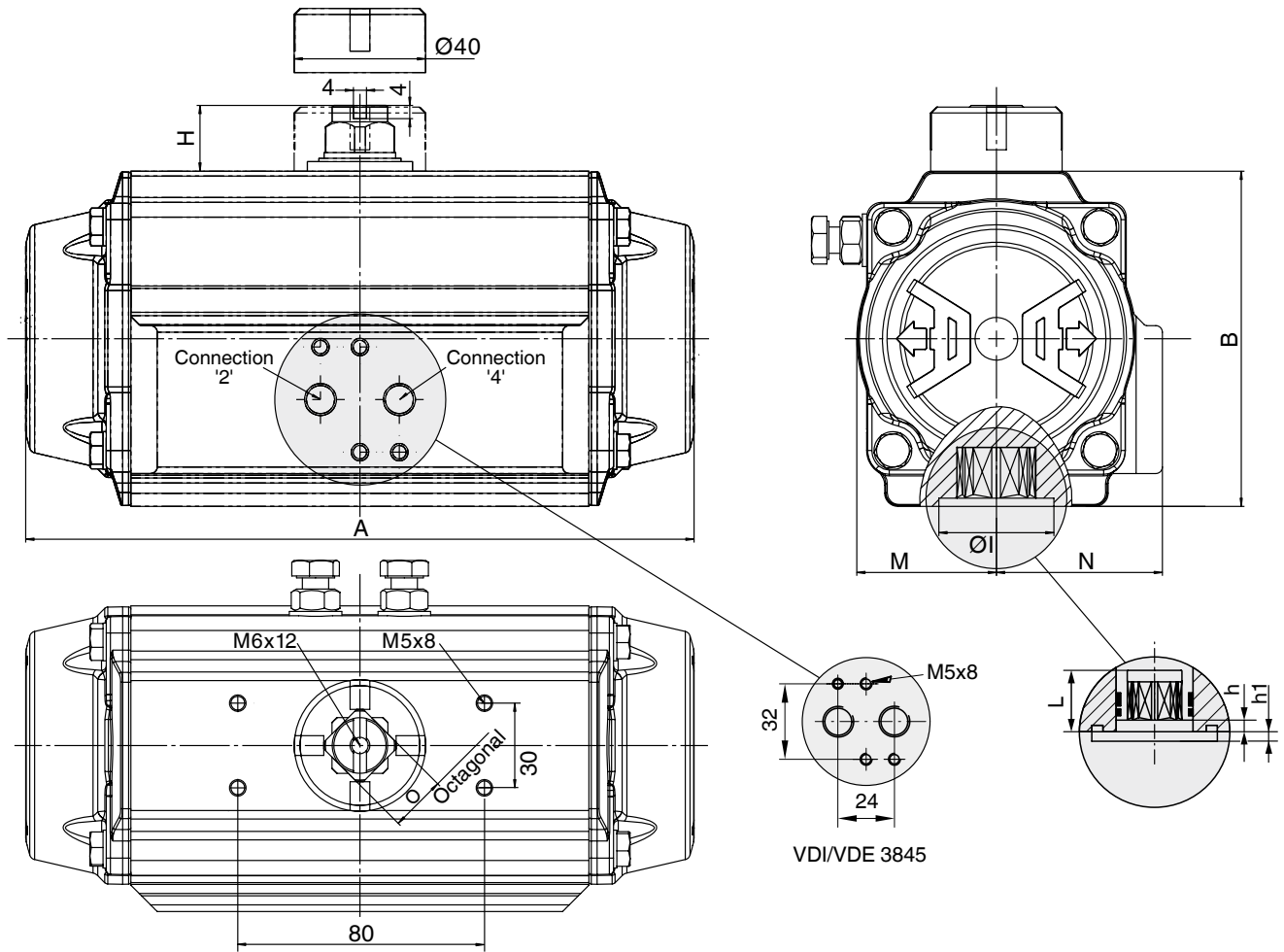

| Typ | 0015U | 0030U | 0060U | 0100U | 0150U | 0220U | 0300U | 0450U |
|----------------------|-------|--------|--------|--------|--------|--------|--------|--------|
| ISO Flange | F04 | F04/05 | F05/07 | F05/07 | F07/10 | F07/10 | F07/10 | F10/12 |
| Octagonal | 11 | 14 | 14 | 17 | 17 | 22 | 22 | 27 |
| Air Connector | G 1/8 | G 1/8 | G 1/8 | G 1/8 | G 1/4 | G 1/4 | G 1/4 | G 1/4 |
| A | 136.0 | 153.5 | 203.5 | 241.0 | 259.0 | 304.0 | 333.0 | 394.5 |
| B | 69.0 | 85.0 | 102.0 | 115.0 | 127.0 | 145.0 | 157.0 | 177.0 |
| H | 20 | 20 | 20 | 20 | 20 | 30 | 30 | 30 |
| Ø I | 30 | 35 | 35 | 40 | 55 | 55 | 55 | 70 |
| M | 29.0 | 36.0 | 42.5 | 49.5 | 55.5 | 64.0 | 69.5 | 80.0 |
| N | 43.0 | 48.5 | 50.5 | 56.5 | 63.0 | 72.0 | 77.0 | 86.0 |
| O | 11 | 11 | 17 | 17 | 17 | 27 | 27 | 27 |
| h | 0.5 | 0.5 | 0.5 | 1.5 | 1.5 | 1.5 | 1.5 | 1.5 |
| h1 | 1.5 | 2.0 | 2.0 | 1.5 | 2.0 | 2.0 | 2.0 | 3.0 |
| L | 11 | 11 | 19 | 19 | 19 | 19 | 25 | 32 |
| Weight [kg] | | | | | | | | |
| DR | 1.0 | 1.6 | 2.7 | 3.8 | 5.4 | 8.4 | 10.2 | 14.5 |
| SC | 1.1 | 1.7 | 3.2 | 4.4 | 6.5 | 9.8 | 12.6 | 18.1 |

Stroke limiter on request

Technical data - GEMÜ 748 - motorized

Travel range

| | |
|---------------------------------|-----------|
| Nominal travel range | 90° |
| Max. travel range | 93° |
| Setting range limit switch Min. | -2 to 12° |
| Setting range limit switch Max. | 76 to 91° |

Manual override

| |
|--|
| With Allen key SW3 for actuator version 1015, 2015, 3035 |
| With hand crank for actuator version 2070, 4100, 4200 |

Permissible temperatures

| | |
|---------------------|---------------|
| Ambient temperature | -10 to +60° C |
| Storage temperature | -20 to +60° C |

Weight

| | |
|-----------------------------|---------|
| Actuator version 1015 | 1.0 kg |
| Actuator version 2015 | 1.2 kg |
| Actuator version 3035 | 2.4 kg |
| Actuator version 2070 | 4.6 kg |
| Actuator version 4100, 4200 | 11.0 kg |

Protection class to EN 60529

IP 65

Actuator materials

| Actuator version | 1015 | 2015, 3035 | 2070 | 4100, 4200 |
|----------------------------|-------------------------------|------------------------------|-------------|------------|
| Housing base | PP (30% glass reinforced) | PP (30% glass reinforced) | ABS | Aluminium |
| Housing cover | PPO (10% glass reinforced) | PP (30% glass reinforced) | ABS | Aluminium |
| Optical position indicator | PPR natural | PPR natural | PPR natural | PMMA |

Correlation Actuator / Ball valve type 748

| Ball valve | | | Actuator version | | | | | |
|------------|-------------|----|------------------|---------------|---------------|---------------|----------------|----------------|
| DN | Flange type | SW | 1015 15 Nm | 2015 15 Nm | 3035 35 Nm | 2070 70 Nm | 4100 100 Nm | 4200 200 Nm |
| 8 | F04 | 9 | X | X | - | - | - | - |
| 10 | F04 | 9 | X | X | - | - | - | - |
| 15 | F04 | 9 | X | X | - | - | - | - |
| 20 | F04 | 9 | X | X | - | - | - | - |
| 25 | F05 | 11 | - | - | X | X | - | - |
| 32 | F05 | 11 | - | - | X | X | - | - |
| 40 | F07 | 14 | - | - | - | X | - | - |
| 50 | F07 | 14 | - | - | - | X | - | - |
| 65 | F10 | 17 | - | - | - | - | X | - |
| 80 | F10 | 17 | - | - | - | - | X | - |
| 100 | F10 | 17 | - | - | - | - | - | X |

Note: For connection and wiring diagrams for motorized GEMÜ actuators see data sheet

Data sheet GEMÜ 9428: Actuator version code 1006, 1015, 2006, 2015, 3035

Data sheet GEMÜ 9468: Actuator version code 2070, 4100, 4200, 6400

Technical data - GEMÜ 748 - motorized

Correlation Actuator version (torque) / Voltage-frequency

| Voltage/Frequency | | B1 12V DC | C1 24V DC | B4 12 V AC | C4 24 V AC | G4 120 V AC | L4 230 V AC | O4 100-250 V AC |
|-------------------|---------------|--------------|--------------|---------------|---------------|----------------|----------------|--------------------|
| Actuator version | 1015 (15 Nm) | X | X | - | - | - | - | - |
| | 2015 (15 Nm) | - | - | X | X | - | - | X |
| | 3035 (35 Nm) | - | X | - | X | - | - | X |
| | 2070 (70 Nm) | - | X | - | X | X | X | - |
| | 4100 (100 Nm) | - | X | - | X | X | X | - |
| | 4200 (200 Nm) | - | X | - | X | X | X | - |

Correlation Actuator version (torque) / Functional module

| Functional module | | A0 | AE | AP | E2 | E1 | 00 | 0E | 0P |
|-------------------|---------------|----|----|----|----|----|----|----|----|
| Actuator version | 1015 (15 Nm) | X | X | - | - | - | - | - | - |
| | 2015 (15 Nm) | X | X | - | - | - | - | - | - |
| | 3035 (35 Nm) | X | X | - | - | - | - | - | - |
| | 2070 (70 Nm) | X | X | X | X | X | X | X | X |
| | 4100 (100 Nm) | X | X | X | X | X | X | X | X |
| | 4200 (200 Nm) | X | X | X | X | X | X | X | X |

Power consumption [W]

| Voltage/ Frequency | | B1 12V DC | | C1 24V DC | | B4 12V AC | | C4 24V AC | | G4 120V AC | | L4 230V AC | | O4 100-250V AC | |
|-----------------------|------|-------------------|-------------|-------------------|-------------|-------------------|-------------|-------------------|-------------|-------------------|-------------|-------------------|-------------|-------------------|-------------|
| Functional module | | A0,AE,AP E1,E2 | 00,0E 0P | A0,AE,AP E1,E2 | 00,0E 0P | A0,AE,AP E1,E2 | 00,0E 0P | A0,AE,AP E1,E2 | 00,0E 0P | A0,AE,AP E1,E2 | 00,0E 0P | A0,AE,AP E1,E2 | 00,0E 0P | A0,AE,AP E1,E2 | 00,0E 0P |
| Actuator version | 1015 | 24 | - | 24 | - | - | - | - | - | - | - | - | - | - | - |
| | 2015 | - | - | - | - | 24 | - | 24 | - | - | - | - | - | 30 | - |
| | 3035 | - | - | 24 | - | - | - | 24 | - | - | - | - | - | 30 | - |
| | 2070 | - | - | 96 | 63 | - | - | - | 63 | 160 | - | 161 | - | - | - |
| | 4100 | - | - | 96 | 105 | - | - | - | 140 | 160 | 105 | 161 | 130 | - | - |
| | 4200 | - | - | 96 | 90 | - | - | - | 110 | 160 | 90 | 161 | 105 | - | - |

Electrical connection

| Actuator version | 1015, 2015, 3035 | | | | 2070, 4100, 4200 | | | |
|------------------------------|-------------------------------------|--|---|--|-------------------------------------|---------------|-----------|--------------|
| Supply voltages | 12 V / 24 V | | 100 - 250 V | | 24 V, 120 V, 230 V | | | |
| Functional module | A0, AE | | | | A0, AE, AP | 00, 0E, 0P | E1 | E2 |
| Control input voltage | Motor voltage | | 20 - 250 V AC/DC | | 24 - 250 V AC/DC | Motor voltage | 0 to 10 V | - |
| Control input current | - | | typ. 1 mA | | typ. 1 mA | | | 0/4 to 20 mA |
| Rating | Continuously rated | | rated 40% | | Continuously rated | | | |
| Connection | Cable connection PG 13,5 | | Hirschmann plug type Typ N6RFFS11 | | Flange plug Binder 692/693 | | | |
| Cable diameter | 7,5 ... 12,5 mm | | 7 ... 9 mm | | max. 8 mm | | | |
| Max. cross section of wire | 1,5 mm ² | | 1,5 mm ² | | 0,75 mm ² | | | |
| Recommended connection cable | 5x1 mm ² | | 1 connector (standard): 7x1 mm ² | | 7x1 mm ² | | | |
| Overload protection | Motor protective system by customer | | Integrated stall and overload protection plus excess current release T 1A 5x20 mm | | Motor protective system by customer | | | |

Order data - GEMÜ 748 - motorized

| 1 Type | Code |
|------------------------------------|------|
| Ball valve with motorized actuator | 748 |

| 2 Nominal size | Code |
|---|------|
| DN 8 1/4" (only connection code 60) | 8 |
| DN 10 3/8" (only connection code 17, 60) | 10 |
| DN 15 1/2" | 15 |
| DN 20 3/4" | 20 |
| DN 25 1" | 25 |
| DN 32 1 1/4" (not connection code 59, 80) | 32 |
| DN 40 1 1/2" | 40 |
| DN 50 2" | 50 |
| DN 65 2 1/2" | 65 |
| DN 80 3" | 80 |
| DN 100 4" | 100 |

| 3 Body configuration* | Code |
|----------------------------|------|
| Straight through (2/2-way) | D |

* Multi-port design on request

| 4 Connection | Code |
|---------------------------------------|------|
| Butt weld spigots DIN 11850, series 2 | 17 |
| Spigots ASME BPE | 59 |
| Spigots EN ISO 1127 | 60 |
| Clamps ASME BPE | 80 |

| 5 Valve body material | Code |
|-------------------------------------|------|
| CF3M (316L), body (investment cast) | C1 |
| CF3M (316L), ball | |

| 6 Seat material | Code |
|---|------|
| TFM™, (modified PTFE, FDA compliant) up to max. 180°C (also for steam up to max. 8 bar) | 5T |
| PTFE, (FDA-compliant) cavity filled seat | 5C |

| 7 Voltage/Frequency | Code |
|----------------------|------|
| 12 V DC | B1 |
| 12 V AC 50/60Hz | B4 |
| 24 V DC | C1 |
| 24 V AC 50/60Hz | C4 |
| 120 V AC 50/60Hz | G4 |
| 100-250 V AC 50/60Hz | O4 |
| 230 V AC 50/60Hz | L4 |

| 8 Functional module | Code |
|--|------|
| OPEN / CLOSE control with relay, not reversible | 00 |
| OPEN / CLOSE control with 2 additional potential-free limit switches, with relay, not reversible | 0E |
| OPEN / CLOSE control with potentiometer output, with relay, not reversible | 0P |
| Standard OPEN/CLOSE control | A0 |
| OPEN/CLOSE control with 2 additional potential-free limit switches | AE |
| AOPEN/CLOSE control with potentiometer output | AP |
| Control module for external set value 0-10V DC | E1 |
| Control module for external set value 0/4-20 mA | E2 |

| 9 Actuator version | Code |
|---|------|
| DN 8-20 (Torque 15 Nm), operating time 11 sec; supply voltage B1/C1 | 1015 |
| DN 8-20 (Torque 15 Nm), operating time 11 sec; supply voltage B4/C4/O4 | 2015 |
| DN 25-50 (Torque 70 Nm), operating time 15 sec; supply voltage C1/C4/G4/L4 | 2070 |
| DN 25 - 32 (Torque 35 Nm) supply voltage C1,C4,O4 | 3035 |
| DN 25-32 (Torque 100 Nm), operating time 20 sec; supply voltage C1/C4/G4/L4 | 4100 |
| DN 100 (Torque 200 Nm), operating time 16 sec; supply voltage C1/C4/G4/L4 | 4200 |

| 10 K number | Code |
|------------------------------|------|
| Mounting flange with adapter | 5222 |

For operating temperatures > 100° C a mounting flange with an adapter is required between ball valve and actuator!
See data sheet: -Accessories for quarter turn valves-

| Order example | 1 | 2 | 3 | 4 | 5 | 6 | 7 | 8 | 9 | 10 |
|---------------|-----|----|---|----|----|----|----|----|------|----|
| | 748 | 25 | D | 60 | C1 | 5T | C1 | A0 | 1015 | - |

Note: Wearing parts kit - order code: SP.K748-DN... (dependent on nominal size) contains replacement parts for the spindle seal and seat: Conical spindle seal (PTFE), V-ring spindle packing (PTFE), seat and flange seals (PTFE)

Actuator dimensions - GEMÜ 748 - motorized

Actuator version 1015, 2015

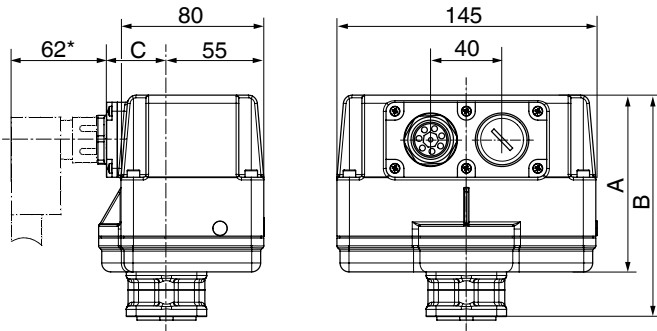

* Standard with supply voltage code O4

| Voltages | ISO 5211 | SW square drive socket | A | B | C |
|-------------|-----------|------------------------|----|-----|----|
| 12 V, 24 V | F04 / F05 | 9 | 69 | 94 | 34 |
| 100 - 250 V | | | 99 | 124 | 38 |

Actuator version 2070

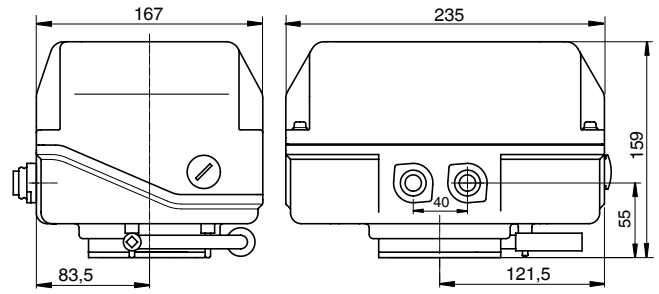

| DN | ISO 5211 without mounting bracket | SW square drive socket |
|-----------------------|-----------------------------------|------------------------|
| 15, 20 | F04 | 9 |
| 40, 50 | F07 | 14 |
| 80, 100 | F10 | 17 |
| with mounting bracket | | |
| 25 | F05 | 11 |
| 65 | F10 | 17 |

Actuator version 3035

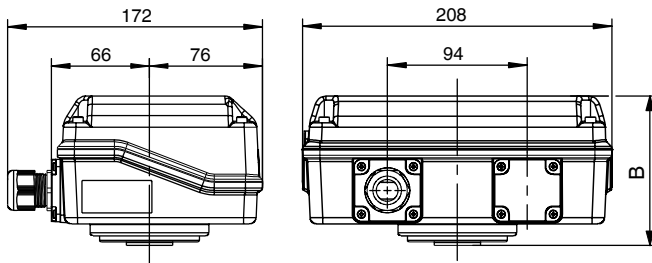

| Voltages | B |
|---------------|-------|
| 24 V | 100.5 |
| 100 V - 250 V | 124.5 |

Actuator version 4100, 4200

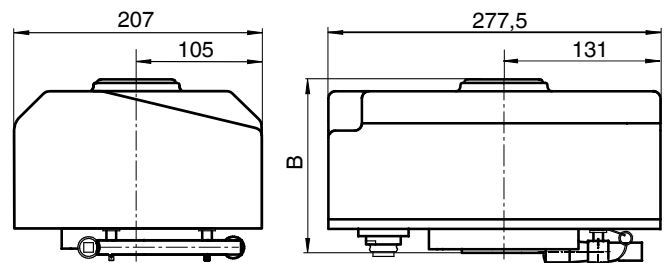

| Functional module | ISO 5211 | SW square drive socket | B |
|--------------------|-----------|------------------------|-----|
| 00, 0E, 0P | F07 + F10 | 17 / 22 | 146 |
| A0, AE, AP, E2, E1 | | | 201 |

For further ball valves and other products, please see our Product Range catalogue and Price List.
Contact GEMÜ.

Technical data sheet

Should there be any doubts or misunderstandings, the German version of this data sheet is the authoritative document!

Subject to alteration · 11/2013 · 88339646