

Diaphragm Valve, Metal

Construction

The GEMÜ 698 motorized 2/2-way diaphragm valve has a low maintenance electric actuator with a toothed belt drive and a reversible synchronous motor. A manual override and an optical position indicator are standard.

Features

- Suitable for inert and corrosive* liquid and gaseous media
- Chemical resistance of actuator
- Stainless steel body with CIP/SIP cleaning and sterilizing capabilities
- Insensitive to particulate media
- Valve body and diaphragm available in various materials and designs
- The valve stroke can be limited by means of adjustable limit switches
- Suitable for use as a control valve (with GEMÜ 1283)

Advantages

- Hermetic separation between medium and actuator
- Optional flow direction, will seal in either flow direction up to full operating pressure
- Optional mounting position
- Consistent control system and reliable opening and closing action
- Direct 0/4 - 20 mA signal processing using the additional module GEMÜ 1283
- Electrical position feedback by means of a potentiometer available as an option

*see information on working medium on page 2



Sectional drawing

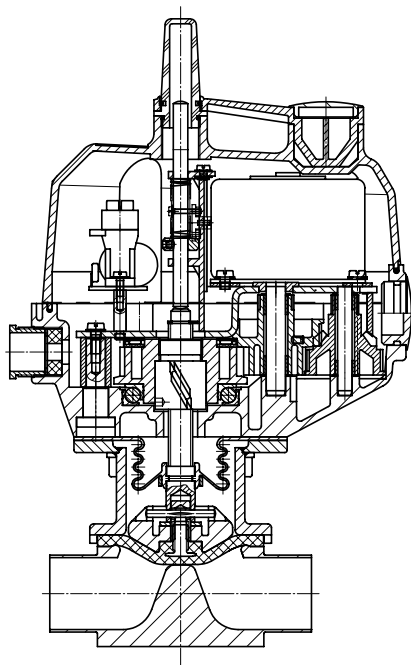

Technical data

Working medium

Corrosive, inert, gaseous and liquid media which have no negative impact on the physical and chemical properties of the body and diaphragm material.

Operating temperature (dependent on medium wetted materials) max. 150 °C

Ambient conditions

Ambient temperature -10 to +55 °C

Storage temperature -15 to +55 °C

Power consumption

10 VA

Optional position feedback

Actual value potentiometer (functional module AP) 10 kW

Rating

Continuously rated

Operating time

Standard version approx. 20 s

Protection class

IP 65 acc. to DIN 40050

Cable gland

2 x PG 13.5

Diaphragm size	DN	Operating pressure [bar]	
		EPDM / FPM	PTFE
25	15, 20, 25	0 - 10	0 - 6
40	32, 40	0 - 6	0 - 6
50	50	0 - 6	0 - 4

All pressures are gauge pressures. Operating pressure values were determined with static operating pressure applied on one side of a closed valve. Sealing at the valve seat and atmospheric sealing is ensured for the given values. Information on operating pressures applied on both sides and for high purity media on request.

Kv values [m³/h]

MG	DN	DIN Code 0	DIN 11850 Series 1 Code 16	DIN 11850 Series 2 Code 17	DIN 11850 Series 3 Code 18	SMS 3008 Code 37	ASME BPE Code 59	EN ISO 1127 Code 60
25	15	4.1	4.7	4.7	4.7	-	-	7.4
	20	6.3	7.0	7.0	7.0	-	4.4	13.2
	25	13.9	15.0	15.0	15.0	12.6	12.2	16.2
40	32	25.3	27.0	27.0	27.0	26.2	-	30.0
	40	29.3	30.9	30.9	30.9	30.2	29.5	32.8
50	50	46.5	48.4	48.4	48.4	51.7	50.6	55.2

Kv values determined acc. to IEC 534 standard, inlet pressure 6 bar, Δp 1 bar, stainless steel valve body and soft elastomer diaphragm. MG = diaphragm size

Diaphragm temperature range [°C]

Diaphragm	Liquid Media		Steam (Sterilisation)	Code
	Min.	Max.		
EPDM	-10	90	150 °C, max. 60 min	13
EPDM	-10	90	150 °C, max. 60 min	16
EPDM	-10	90	150 °C, max. 180 min	17
PTFE	-10	90	Constant temperature* 150 °C	5E
FPM	-10	90	not applicable	4
EPDM	-10	90	not applicable	14
PTFE	-10	90	150 °C, max. 40 min	5F

* The valves concerned must be serviced regularly if steam is applied continuously

Order data

Body configuration	Code
Tank valve body	B**
2/2-way body	D
Multi-port design	M**
T body	T*
* For dimensions see T Valves brochure	
** Dimensions and versions on request or according to customer requirements	

Connection	Code
Butt weld spigots	
Spigots DIN	0
Spigots DIN 11850, series 1	16
Spigots DIN 11850, series 2	17
Spigots DIN 11850, series 3	18
Spigots DIN 11866, series A	1A
Spigots DIN 11866, series B	1B
Spigots JIS-G 3447	35
Spigots JIS-G 3459	36
Spigots SMS 3008	37
Spigots BS 4825, part 1	55
Spigots ASME BPE	59
Spigots EN ISO 1127	60
Spigots ANSI/ASME B36.19M, Schedule 10s	63
Spigots ANSI/ASME B36.19M, Schedule 40s	65
Threaded connections	
Threaded sockets DIN ISO 228	1
Threaded spigots DIN 11851	6
One side threaded spigot, other side cone spigot and union nut, DIN 11851	62
Aseptic unions on request	
Flanges	
Flanges EN 1092 / PN16 / form B, length EN 558, series 1, ISO 5752, basic series 1	8
Flanges ANSI CLASS 125/150 RF length MSS SP-88	38
Flanges ANSI CLASS 125/150 RF length EN 558, series 1, ISO 5752, basic series 1	39
Clamp connections	
Clamps ASME BPE for pipe ASME BPE, length ASME BPE	80
Clamps DIN 32676 series B for pipe EN ISO 1127, length EN 558, series 7	82
Clamps ASME BPE for pipe ASME BPE, length EN 558, series 7	88
Clamps DIN 32676 series A for pipe DIN 11850, length EN 558, series 7	8A
Clamps SMS 3017 for pipe SMS 3008, length EN 558, series 7	8E
Aseptic clamps on request	
For overview of available valve bodies see page 8	

Valve body material	Code
EN-GJL-250, (GG25) (Cast iron)	8
EN-GJS-400-18-LT (S.G. Iron 40.3), PFA lined	17
EN-GJS-400-18-LT (S.G. Iron 40.3), PP lined	18
1.4435 - BN2 (CF3M), investment casting Fe<0.5%	32
1.4435 (ASTM A 351 CF3M \cong 316L), investment casting	34
1.4408, investment casting	37
1.4408, PFA lined	39
1.4435 (316L), forged body	40
1.4435 (BN2), forged body Fe<0.5%	42
EN-GJS-400-18-LT (S.G. Iron 40.3), hard rubber lined	83

Diaphragm material	Code
FPM	4
EPDM	13
EPDM	14
EPDM	16
EPDM	17
PTFE/EPDM convex, PTFE loose	5E
PTFE/FPM convex, PTFE loose	5F
Material complies with FDA requirements, except codes 4 and 14	

Supply voltage	Code
24 V \pm 10%	C
120 V \pm 10%	G
230 V \pm 10%	L

Mains frequency	Code
50/60 Hz	4

Functional module	Code
OPEN / CLOSE control with additional end position feedback	AE
OPEN / CLOSE control with potentiometer output	AP

For further order data see page 4

Order data

Valve body surface finish, internal contour

		Forged body Code 40, 42	Investment casting Code 32, 34	Code
Ra ≤ 6.3 µm	blasted internal/external	-	X	1500
--	electropolished	-	X	1509
Ra ≤ 0.8 µm	mechanically polished internal, blasted external	X	X	1502
Ra ≤ 0.8 µm	electropolished internal/external	X	-	1503
Ra ≤ 0.6 µm	mechanically polished internal, blasted external	X	X	1507
Ra ≤ 0.6 µm	electropolished internal/external	X	-	1508
Ra ≤ 0.4 µm	mechanically polished internal, blasted external	X	-	1536
Ra ≤ 0.4 µm	electropolished internal/external	X	-	1537
Ra ≤ 0.25 µm	mechanically polished internal, blasted external	X	-	1527
Ra ≤ 0.25 µm	electropolished internal/external	X	-	1516

Ra acc. to DIN 4768; at defined reference points
Surface finish data refer to medium wetted surfaces

Order example	698	25	D	60	34	13	L	4	AE	1500
Type	698									
Nominal size		25								
Body configuration (code)			D							
Connection (code)				60						
Valve body material (code)					34					
Diaphragm material (code)						13				
Supply voltage (code)							L			
Mains frequency (code)								4		
Functional module (code)									AE	
Surface finish (code)										1500

Dimensions [mm]

Actuator dimensions

Diaphragm size	DN	□B	A	A1	Weight [kg]
25	15 - 25	169 x 135	222	82	2.35
40	32 - 40	169 x 135	271	131	2.90
50	50	169 x 135	278	138	3.30

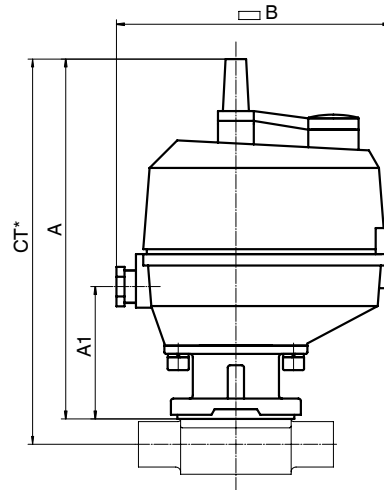

* CT = A + H1 (see body dimensions)

Body dimensions [mm]

Threaded sockets, connection code 1
Valve body material: GG25 (code 8), investment casting (code 37)

MG	DN	R	L	Material code 8					Material code 37					Weight [kg]
				H	H1	t	SW2	Number of flats	H	H1	t	SW2	Number of flats	
25	15	1/2"	85	35	19	12	32	6	30	16	9	27	6	0.32
	20	3/4"	85	40	19	13	41	6	33	17	10	32	6	0.34
	25	1"	110	42	19	16	46	6	37	17	13	41	6	0.39
40	32	1 1/4"	120	56	28	16	55	6	50	25	16	50	8	0.88
	40	1 1/2"	140	61	28	18	65	6	52	25	18	55	8	0.93
50	50	2"	165	73	35	18	75	6	69	34	18	70	8	1.56

MG = diaphragm size

For materials see overview on last page

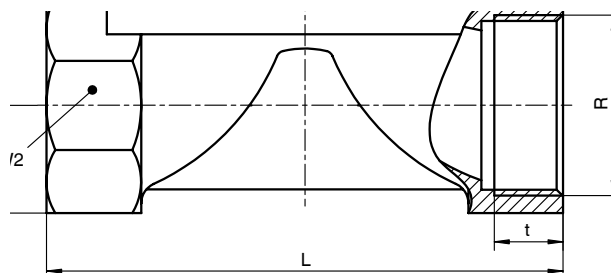

Body dimensions [mm]

Butt weld spigots, connection code 0, 16, 17, 18 Valve body material: Investment casting (code 34), forged body (code 40)

MG	DN	NPS	f*	øg*	L	c	H1*	H1**	DIN Series 0 Code 0		DIN 11850 Series 1 Code 16		DIN 11850 Series 2 Code 17		DIN 11850 Series 3 Code 18		Weight [kg]
									ød	s	ød	s	ød	s	ød	s	
25	15	1/2"	40	13.5	120	25	13.0	19.0	18	1.5	18	1.0	19	1.5	20	2.0	0.62
	20	3/4"	40	13.5	120	25	16.0	19.0	22	1.5	22	1.0	23	1.5	24	2.0	0.58
	25	1"	40	13.5	120	25	19.0	19.0	28	1.5	28	1.0	29	1.5	30	2.0	0.55
40	32	1 1/4"	68	13.5	153	25	24.0	26.0	34	1.5	34	1.0	35	1.5	36	2.0	1.45
	40	1 1/2"	75	13.5	153	25	26.0	26.0	40	1.5	40	1.0	41	1.5	42	2.0	1.32
50	50	2"	90	13.5	173	30	32.0	32.0	52	1.5	52	1.0	53	1.5	54	2.0	2.25

* only for investment cast design ** only for forged design MG = diaphragm size
For materials see overview on last page

Butt weld spigots, connection code 1A, 1B, 60 Valve body material: Investment casting (code 34), forged body (code 40)

MG	DN	NPS	f*	øg*	L	c	H1*	H1**	DIN 11866 Series A Code 1A		DIN 11866 Series B Code 1B		EN ISO 1127 Code 60		Weight [kg]
									ød	s	ød	s	ød	s	
25	15	1/2"	40	13.5	120	25	13.0	19.0	19	1.5	21.3	1.6	21.3	1.6	0.62
	20	3/4"	40	13.5	120	25	16.0	19.0	23	1.5	26.9	1.6	26.9	1.6	0.58
	25	1"	40	13.5	120	25	19.0	19.0	29	1.5	33.7	2.0	33.7	2.0	0.55
40	32	1 1/4"	68	13.5	153	25	24.0	26.0	35	1.5	42.4	2.0	42.4	2.0	1.45
	40	1 1/2"	75	13.5	153	25	26.0	26.0	41	1.5	48.3	2.0	48.3	2.0	1.32
50	50	2"	90	13.5	173	30	32.0	32.0	53	1.5	60.3	2.0	60.3	2.0	2.25

* only for investment cast design ** only for forged design MG = diaphragm size
For materials see overview on last page

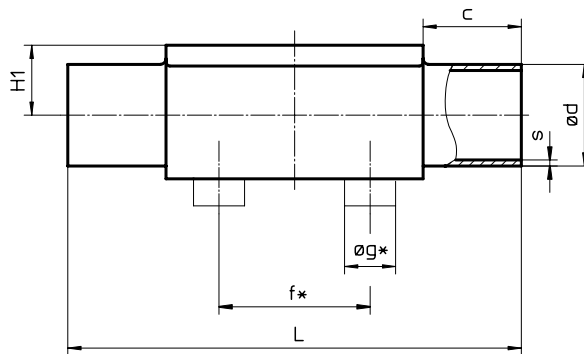

Body dimensions [mm]

Butt weld spigots, connection code 35, 36, 37 Valve body material: Investment casting (code 34), forged body (code 40)

MG	DN	NPS	f*	øg*	L	c	H1*	H1**	JIS-G 3447 Code 35		JIS-G 3459 Code 36		SMS 3008 Code 37		Weight [kg]
									ød	s	ød	s	ød	s	
25	15	1/2"	40	13.5	120	25	13.0	19.0	-	-	21.7	2.10	-	-	0.62
	20	3/4"	40	13.5	120	25	16.0	19.0	-	-	27.2	2.10	-	-	0.58
	25	1"	40	13.5	120	25	19.0	19.0	25.4	1.2	34.0	2.80	25.0	1.2	0.55
40	32	1 1/4"	68	13.5	153	25	24.0	26.0	31.8	1.2	42.7	2.80	33.7	1.2	1.45
	40	1 1/2"	75	13.5	153	25	26.0	26.0	38.1	1.2	48.6	2.80	38.0	1.2	1.32
50	50	2"	90	13.5	173	30	32.0	32.0	50.8	1.5	60.5	2.80	51.0	1.2	2.25

* only for investment cast design ** only for forged design MG = diaphragm size
For materials see overview on last page

Butt weld spigots, connection code 55, 59, 63, 65 Valve body material: Investment casting (code 34), forged body (code 40)

MG	DN	NPS	f*	øg*	L	c	H1*	H1**	BS 4825 Code 55		ASME BPE Code 59		ANSI/ASME B36.19M 10s Code 63		ANSI/ASME B36.19M 40s Code 65		Weight [kg]
									ød	s	ød	s	ød	s	ød	s	
25	15	1/2"	40	13.5	120	25	13.0	19.0	-	-	-	-	21.3	2.11	21.3	2.77	0.62
	20	3/4"	40	13.5	120	25	16.0	19.0	19.05	1.2	19.05	1.65	26.7	2.11	26.7	2.87	0.58
	25	1"	40	13.5	120	25	19.0	19.0	-	-	25.40	1.65	33.4	2.77	33.4	3.38	0.55
40	32	1 1/4"	68	13.5	153	25	24.0	26.0	-	-	-	-	42.2	2.77	42.2	3.56	1.45
	40	1 1/2"	75	13.5	153	25	26.0	26.0	-	-	38.10	1.65	48.3	2.77	48.3	3.68	1.32
50	50	2"	90	13.5	173	30	32.0	32.0	-	-	50.80	1.65	60.3	2.77	60.3	3.91	2.25

* only for investment cast design ** only for forged design MG = diaphragm size
For materials see overview on last page

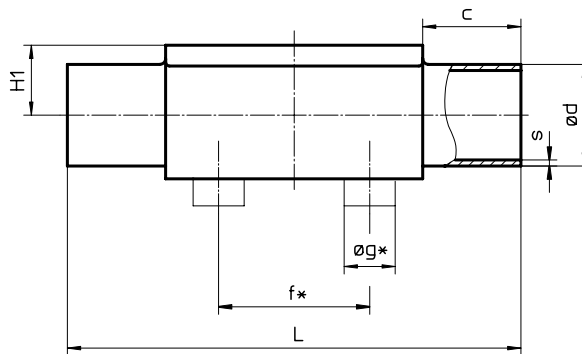

Body dimensions [mm]

Flanges - DIN EN 1092, connection code 8
Valve body material: GG25 (code 8), S.G. Iron 40.3 (code 17, 18, 83),
1.4435 (code 34, 40), 1.4408 (code 39)

MG	DN	øD	øk	øL	Number of bolt	H1				FTF	Weight [kg]
						Material code 8	Material code 17, 18, 39, 83	Material code 34	Material code 40		
25	15	95	65	14	4	19.0	18.0	13.0	19.0	130*	1.85
	20	105	75	14	4	19.0	20.5	16.0	19.0	150	2.35
	25	115	85	14	4	19.0	23.0	19.0	19.0	160	2.85
40	32	140	100	18	4	28.0	28.7	24.0	26.0	180	4.90
	40	150	110	18	4	28.0	33.0	26.0	26.0	200	5.65
50	50	165	125	18	4	35.0	39.0	32.0	32.0	230	7.45

*Material code 34, 40 FTF = 150 (no DIN length) MG = diaphragm size For materials see overview on last page

Flanges - ANSI class 125/150 RF, connection code 38, 39
Valve body material: GG25 (code 8), S.G. Iron 40.3 (code 17, 18, 83),
1.4435 (code 34, 40), 1.4408 (code 39)

MG	DN	øD	øk	øL	Number of bolt	H1				FTF		Weight [kg]	
						Connection code 38, 39				MSS Sp-88 Connection-code 38			EN 558 Series 1 Connection-code 39
										Material code 8	Material code 17, 18, 39, 83		Material code 34
25	15	90	60.3	15.9	4	19.0	18.0	13.0	19.0	-	-	130	1.85
	20	100	69.9	15.9	4	19.0	20.5	16.0	19.0	146	146.4	150	2.35
	25	110	79.4	15.9	4	19.0	23.0	19.0	19.0	146	146.4	160	2.85
40	32	115	88.9	15.9	4	28.0	28.7	24.0	26.0	-	-	180	4.90
	40	125	98.4	15.9	4	28.0	33.0	26.0	26.0	175	171.4	200	5.65
50	50	150	120.7	19.0	4	35.0	39.0	32.0	32.0	200	197.4	230	7.45

MG = diaphragm size For materials see overview on last page

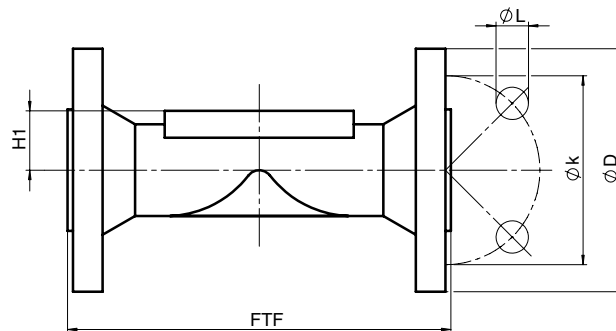

Body dimensions [mm]

Threaded connections, connection code 6, 62 Valve body material: investment casting (code 34), forged body (code 40)

MG	DN	H1*	H1**	f*	øg*	ød1	Thread to DIN 405 R	Code 6 L	Code 62 L	Weight [kg]
25	15	13.0	19	40.0	13.5	16.0	RD 34 x 1/8	118	116	0.71
	20	16.0	19	40.0	13.5	20.0	RD 44 x 1/6	118	114	0.78
	25	19.0	19	40.0	13.5	26.0	RD 52 x 1/6	128	127	0.79
40	32	24.0	26	68.0	13.5	32.0	RD 58 x 1/6	147	147	1.66
	40	26.0	26	75.0	13.5	38.0	RD 65 x 1/6	160	160	1.62
50	50	32.0	32	90.0	13.5	50.0	RD 78 x 1/6	191	191	2.70

* only for investment cast design

** only for forged design

MG = diaphragm size

For materials see overview on last page

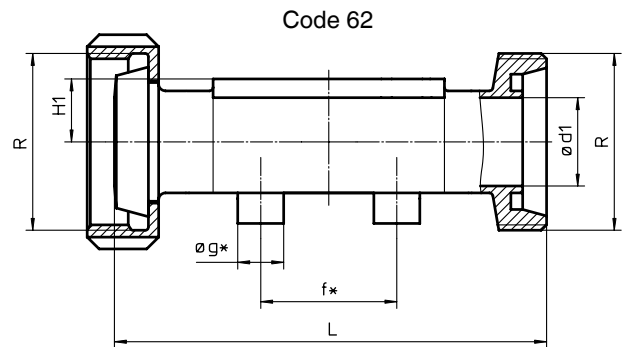
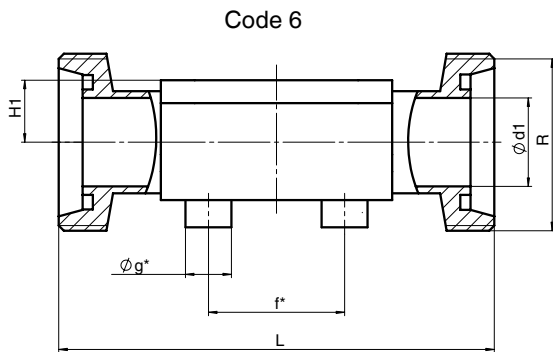

Clamp connections, connection code 80, 82, 88, 8A, 8E Valve body material: forged body (code 40)

MG	DN	NPS	H1	for pipe ASME BPE Code 80			for pipe EN ISO 1127 Code 82			for pipe ASME BPE Code 88			for pipe DIN 11850 Code 8A			for pipe SMS 3008 Code 8E			Weight [kg]
				ød1	ød3	L	ød1	ød3	L	ød1	ød3	L	ød1	ød3	L	ød1	ød3	L	
25	15	1/2"	19.0	-	-	-	18.1	50.5	108.0	-	-	-	16	34.0	108.0	-	-	-	0.75
	20	3/4"	19.0	15.75	25.0	101.6	23.7	50.5	117.0	15.75	25.0	117	20	34.0	117.0	-	-	-	0.71
	25	1"	19.0	22.10	50.5	114.3	29.7	50.5	127.0	22.10	50.5	127	26	50.5	127.0	22.6	50.5	127	0.63
40	32	1 1/4"	26.0	-	-	-	38.4	64.0	146.0	-	-	-	32	50.5	146.0	31.3	50.5	146	1.62
	40	1 1/2"	26.0	34.80	50.5	139.7	44.3	64.0	159.0	34.80	50.5	159	38	50.5	159.0	35.6	50.5	159	1.50
50	50	2"	32.0	47.50	64.0	158.8	56.3	77.5	190.0	47.50	64.0	190	50	64.0	190.0	48.6	64.0	190	2.50

MG = diaphragm size

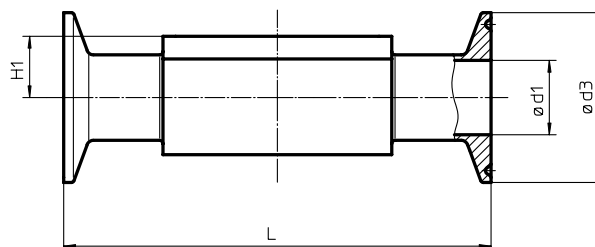

Overview of valve bodies for GEMÜ 698

		Threaded connections						Spigots																											
Connection code		1		6		62		0		16		17		18		1A		1B		35		36		37		55		59		60		63		65	
Material code		8	37	34	40	34	40	34	40	34	40	34	40	34	40	40	40	34	40	40	34	40	40	34	40	34	40	34	40	40	40	40	40		
MG	DN																																		
25	15	X*	X	W	W	W	W	X	X	X	X	X	X	-	X	X	X	-	-	X	-	-	-	-	-	-	-	-	X	X	X	X			
	20	X*	X	W	W	W	W	X	X	X	X	X	X	-	X	X	X	-	-	X	-	-	X	X	X	X	X	X	X	X	X	X			
	25	X*	X	W	W	W	W	X	X	X	X	X	X	X	X	X	X	X	X	X	X	X	X	-	-	X	X	X	X	X	X	X			
40	32	X*	X	W	W	W	W	X	X	X	X	X	X	X	X	X	X	X	X	X	X	X	-	-	-	-	X	X	X	X	X				
	40	X*	X	W	W	W	W	X	X	X	X	X	X	X	X	X	X	X	X	X	X	X	-	-	X	X	X	X	X	X	X				
50	50	X*	X	W	W	W	W	X	X	X	X	X	X	X	X	X	X	X	X	X	X	X	-	-	X	X	X	X	X	X	X				

*Valve bodies are not suitable for use with diaphragms code 5E, 5F MG = diaphragm size
 X = Standard W = Welded construction

		Clamps					Flanges																			
Connection code		80	82	88	8A	8E	8						38					39								
Material code		40	40	40	40	40	8	17	18	34	39	40	83	17	18	39	83	8	17	18	34	39	40	83		
MG	DN																									
25	15	-	W	-	K	-	X*	X	X	W	X	W	X	-	-	-	-	X*	X	X	W	X	W	X*		
	20	K	K	K	K	-	X*	X	X	W	X	W	X	X	X	X	X*	X*	X	X	W	X	W	X*		
	25	K	K	K	K	K	X*	X	X	W	X	W	X	X	X	X	X*	X*	X	X	W	X	W	X*		
40	32	-	W	-	K	K	X*	X	X	W	X	W	X	-	-	-	-	X*	X	X	W	X	W	X*		
	40	K	W	K	K	K	X*	X	X	W	X	W	X	X	X	X	X*	X*	X	X	W	X	W	X*		
50	50	K	W	K	K	K	X*	X	X	W	X	W	X	X	X	X	X*	X*	X	X	W	X	W	X*		

*Valve bodies are not suitable for use with diaphragms code 5E, 5F MG = diaphragm size
 X = Standard
 K = Connections completely machined (not welded) in material code 40
 W = Welded construction

Connection code 38 / Material code 18 on request
 Availability of material code 32 same as code 34, code 42 same as code 40

Connection diagram GEMÜ 698

Functional module AE

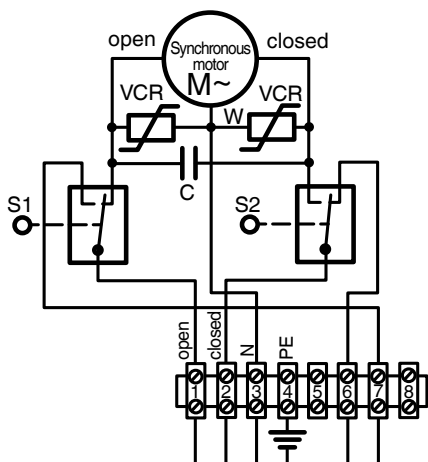

Functional module AP

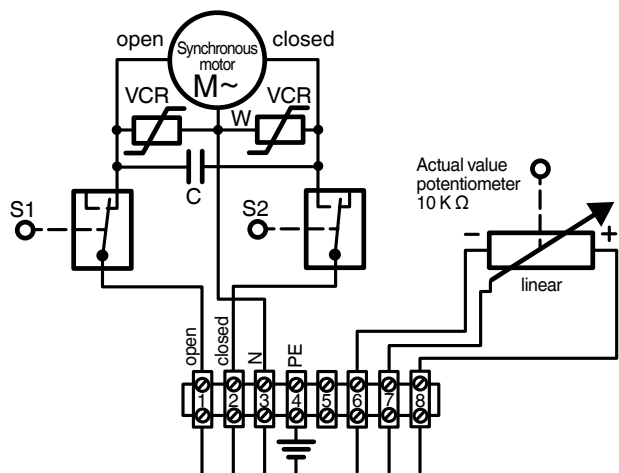

For further metal diaphragm valves, accessories and other products,
 please see our Product Range catalogue and Price List. Contact GEMÜ.

GEMÜ® VALVES, MEASUREMENT
 AND CONTROL SYSTEMS

