

Diaphragm Valve, Plastic

Construction

The GEMÜ 610 pneumatically operated 2/2-way diaphragm valve has a low maintenance plastic piston actuator which can be controlled by inert gaseous media. Normally Closed, Normally Open and Double Acting control functions are available.

Features

- Suitable for inert and corrosive* liquid and gaseous media
- The valve is insensitive to contaminated, abrasive media
- Integrated optical position indicator
- Compact design
- Valve body and diaphragm available in various materials and designs
- Optional flow direction and mounting position

Advantages

- All medium wetted parts and housing made of plastic
- Optional accessories
 - Stroke limiter
 - Electrical position indicator
 - Electrical position indicator with microswitches or proximity switches
- Special solutions and block versions on request

*see information on working medium on page 2



Sectional drawing

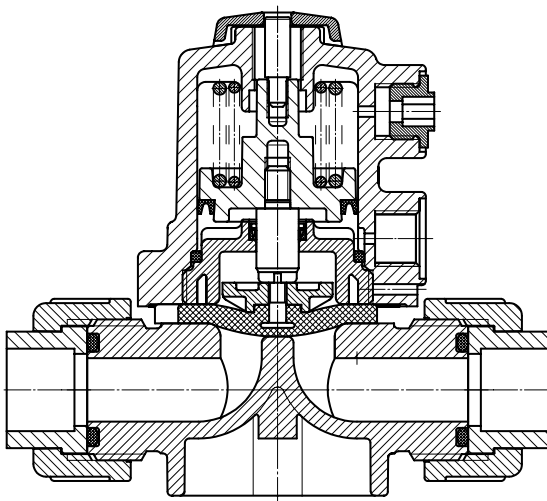

Technical data

Working medium

Corrosive, inert, gaseous and liquid media which have no negative impact on the physical and chemical properties of the body and diaphragm material.

Ambient temperature

Valve body PVC-U	10 to 50 °C
Valve body PP / PP-H	5 to 50 °C
Valve body PVDF	-10 to 50 °C

Working medium temperature

Valve body PVC-U	10 to 60 °C
Valve body PP / PP-H	5 to 80 °C
Valve body PVDF	-20 to 80 °C

The permissible operating pressure depends on the working medium temperature.

Control medium

Inert gases	
Max. perm. temperature of control medium	40 °C
Filling volume	0.02 dm ³

Pressure / temperature correlation for plastic

Temperature in °C (plastic body)		-20	-10	±0	5	10	20	25	30	40	50	60	70	80
Valve body material		Permissible operating pressure [bar]												
PVC-U	Code 1	-	-	-	-	6.0	6.0	6.0	4.8	3.6	2.1	0.9	-	-
PP / PP-H	Code 5 / N5	-	-	-	6.0	6.0	6.0	6.0	5.1	4.2	3.3	2.4	1.6	0.9
PVDF	Code 20	6.0	6.0	6.0	6.0	6.0	6.0	6.0	5.4	4.8	4.3	3.8	3.2	2.8

Data for extended temperature ranges on request. Please note that the ambient temperature and medium temperature generate a combined temperature at the valve body which must not exceed the above values.

Diaphragm size		Operating pressure [bar]	Control pressure [bar]			Kv value [m ³ /h]
DN			Stf. 1	Stf. 2	Stf. 3	
10	12	0 - 6	5 - 7	max. 5.5 see diagram	max. 5.0	2.8
	15					3.5
	20					3.5

All pressures are gauge pressures. Operating pressure values were determined with static operating pressure applied on one side of a closed valve. Sealing at the valve seat and atmospheric sealing is ensured for the given values. Information on operating pressures applied on both sides and for high purity media on request. Control pressure values depend on the valve stroke.

Kv values determined acc. to IEC 534 standard, inlet pressure 6 bar, Δp 1 bar, PVC-U valve body and soft elastomer diaphragm.

O-ring material for valve bodies with union ends

Diaphragm material	O-ring material
NBR	EPDM
FPM	FPM
EPDM	EPDM
PTFE	FPM
Other combinations on request	

With pneumatically operated diaphragm valves there is an interdependence between control pressure and operating pressure regarding the valve stroke.

With valves closed by spring pressure this means: The lower the operating pressure, the higher the control pressure must be to open the valve completely. With valves opened by spring pressure the opposite applies.

In principle care has to be taken that the stated maximum pressures are not exceeded and that the minimum pressures are adhered to.

Required control pressures can be seen from the adjacent diagram.

Control pressure/operating pressure diagram

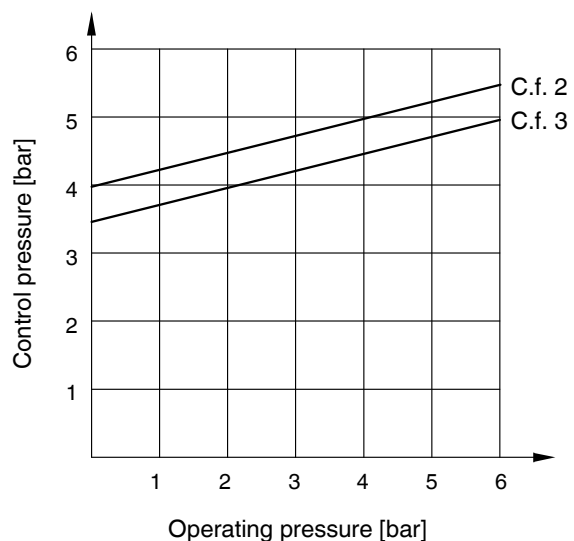

Order data

Body configuration	Code
2/2-way body	D

Connection	Code
Threaded sockets DIN ISO 228	1
Solvent cement sockets DIN	2
Union ends with DIN insert (socket)	7
Spigots for IR butt welding, BCF	28
Union ends with inch insert - BS (socket)	33
Flare connection with PVDF union nut	75
Union ends with DIN insert (for IR butt welding)	78

Valve body material	Code
PVC-U, grey	1
PP, reinforced	5
PVDF	20
PP-H natural	N5*
* only with integrated mounting plate (code M)	

Diaphragm material	Code
NBR	2
FPM	4
EPDM	14
PTFE/EPDM, PTFE laminated	52

Control function	Code
Normally closed (NC)	1
Normally open (NO)	2
Double acting (DA)	3

Actuator size	Code
Diaphragm size 10 Control air connector at 90° to flow direction	1/N
Diaphragm size 10 Control air connector in flow direction	1RN

Integrated mounting plate	Code
With integrated mounting plate Material code 20, N5	M
Without mounting plate Material code 20	O
Without mounting plate Material code 1 and 5	-

Order example	610	15	D	7	1	14	1	1/N	-
Type	610								
Nominal size		15							
Body configuration (code)			D						
Connection (code)				7					
Valve body material (code)					1				
Diaphragm material (code)						14			
Control function (code)							1		
Actuator size (code)								1/N	
Integrated mounting plate (code)									-

Dimensions [mm]

Actuator dimensions

MG	DN	A	A1	A2	B	B1	B2	G	M	Weight [kg]
10	12 - 20	82	21	30	57	35	68	G 1/4	M12x1	0.18

MG = Diaphragm size

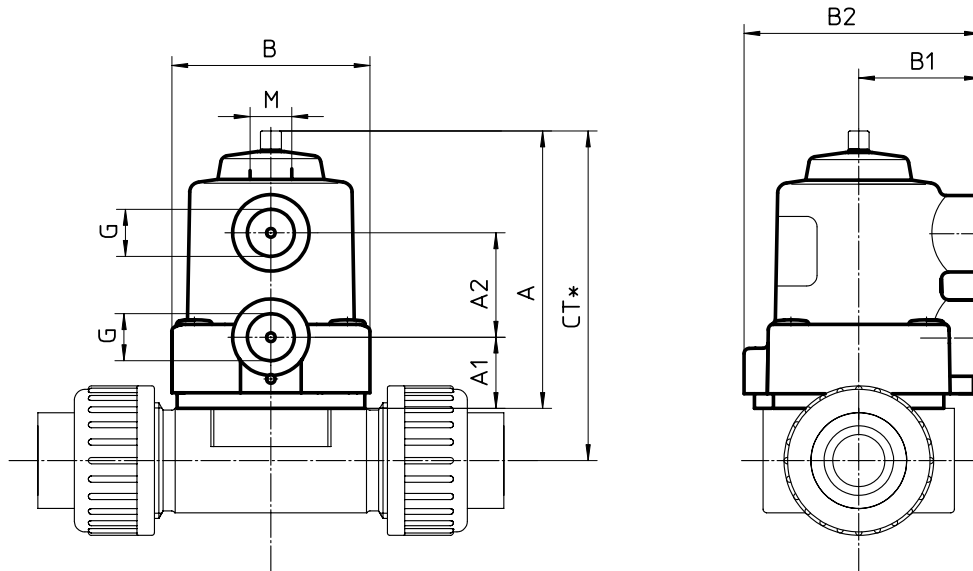

Valve body mounting dimensions [mm]

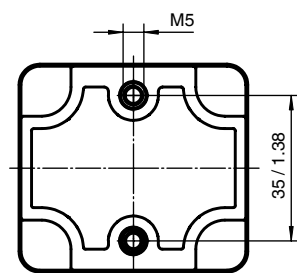

Dimensions of mounting plate Code M [mm]

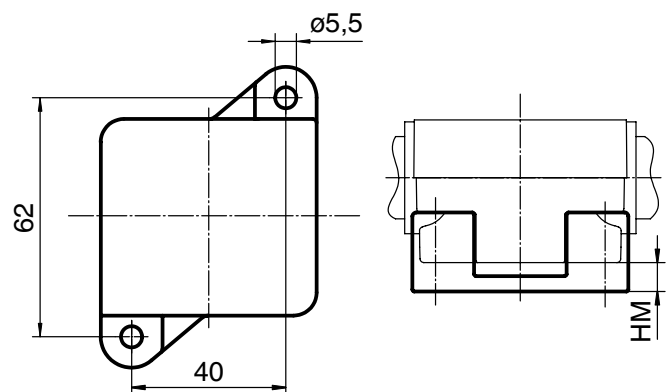

Diaphragm size	M	f
10	M5	35.0

Diaphragm size	Material code 20, N5	HM
10	DN 12	5.0
	DN 15	4.5
	DN 20	4.5

Body dimensions [mm]

Threaded sockets, connection code 1 Valve body material: PVC-U (code 1), PP (code 5), PVDF (code 20)

MG	DN	R	t	H		H1		L	Weight [kg]
				Material code 1, 5	Material code 20	Material code 1, 5	Material code 20		
10	12	G3/8	13	27.5	31.5	12.5	12.5	55	0.08

For materials see overview on last page MG = diaphragm size

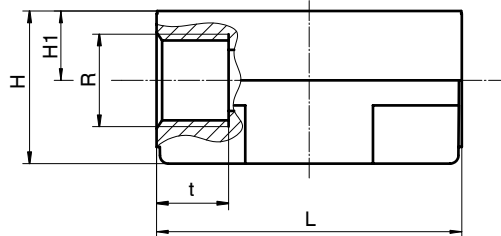

Solvent cement sockets, connection code 2 Valve body material: PVC-U (code 1)

MG	DN	ø D	t	H	H1	L	Weight [kg]
10	12	16	13	27.5	12.5	55	0.06

MG = diaphragm size

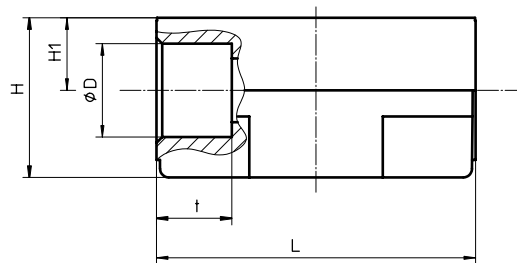

Dimensions [mm]

Union ends with DIN insert (socket), connection code 7 Valve body material: PVC-U (code 1), PP (code 5), PVDF (code 20)*, PP-H (code N5)*

MG	DN	L1	L2		H		H1		øD	ød	R	Weight [kg]
			Material code 1, 20	Material code 5, N5	Material code 1, 5	Material code 20, N5	Material code 1, 5	Material code 20, N5				
10	15	90	128	125	30	41	15	16	43	20	G1	0.18

* with integrated mounting plate (code M), note dimension HM (see page 4)
For materials see overview on last page MG = diaphragm size

Union ends with inch insert (socket), connection code 33 Valve body material: PVC-U (code 1)

MG	DN	NPS	L1	L2	H	H1	øD	ød	R	Weight [kg]
10	15	1/2"	90	128	30	15	43	21.4	G1	0.13

MG = diaphragm size

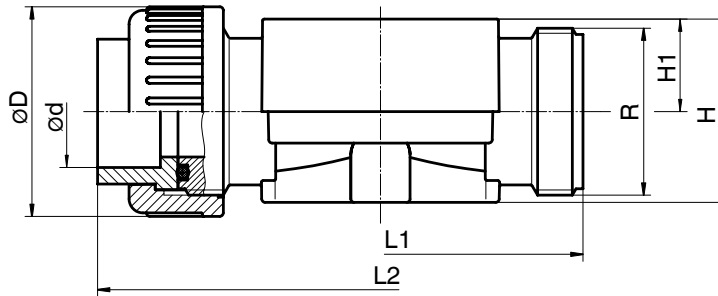

Spigots for IR butt welding, BCF, connection code 28 Valve body material: PVDF (code 20)

MG	DN	L	H	H1	ød	s	c	c1	Weight [kg]
10	15	134	41	16	20	1.9	31	37	0.13

MG = diaphragm size

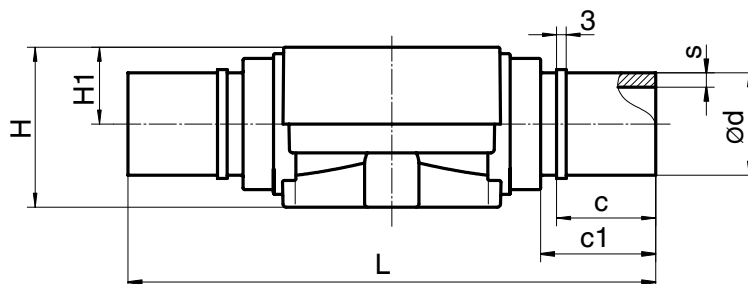

Body dimensions [mm]

Flare connection with PVDF union nut, connection code 75
Valve body material: PP-H (code N5)

MG	DN	L	H	H1	øD	N1	N2	øN3	Weight [kg]
10	15	132	38.1	10	26.5	40	62.0	5.5	0.08
	20	134	44.5	15	26.5	40	62.0	5.5	0.125

MG = diaphragm size

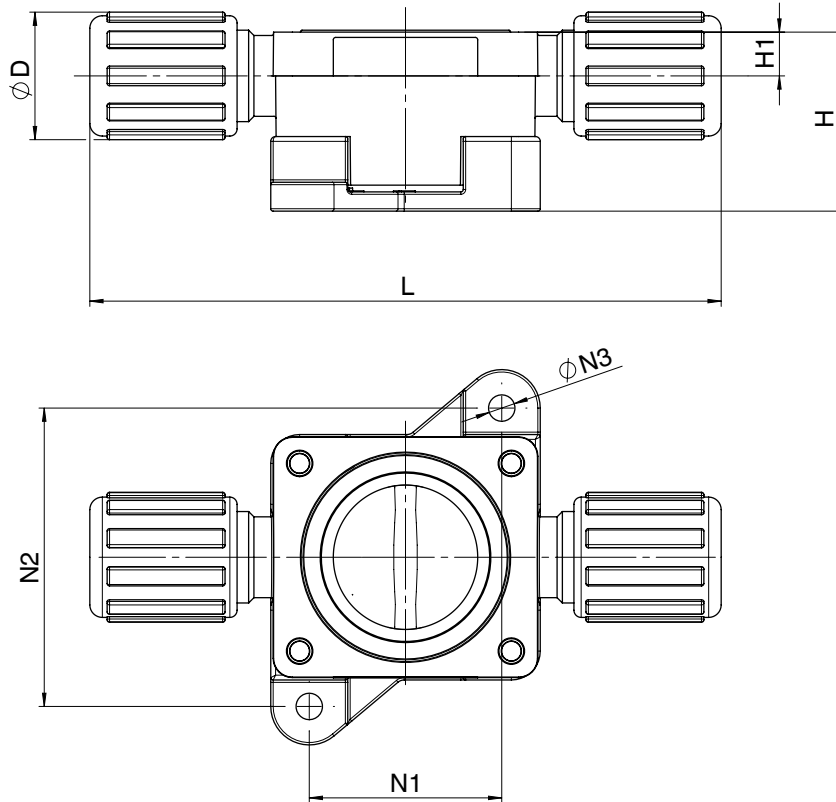

Body dimensions [mm]

Union ends with DIN insert, connection code 78
Valve body material: PP (code 5), PVDF (code 20)*, PP-H (code N5)*,

Diaphragm size	DN	L1	L2	H		H1		øD	R	ød	s	c	Weight [kg]
				Material code 5	Material code 20, N5	Material code 5	Material code 20						
10	15	90	196	30	41	15	16	42	1	20	1.9	36	0.20

* with integrated mounting plate (code M), note dimension HM (see page 4)
 For materials see overview below

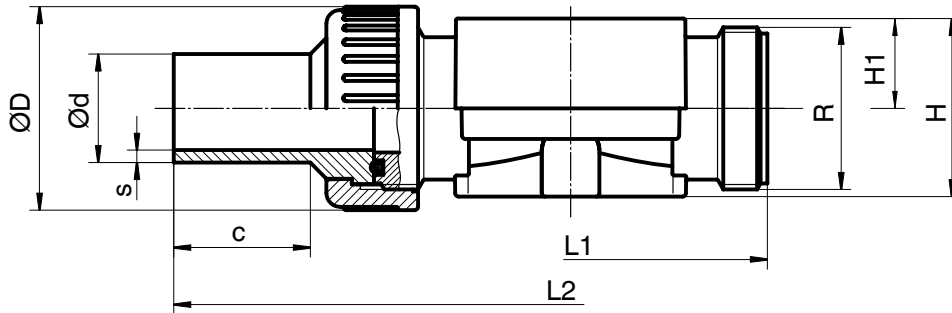

Overview of valve bodies for GEMÜ 610

Connection code		1			2	7				28	33	75	78			
Material code		1	5	20	1	1	5	20	N5	20	1	N5	5	20	N5	
MG	DN															
10	12	X	X	X	X	-	-	-	-	-	-	-	-	-	-	-
	15	-	-	-	-	X	X	X	X	X	X	X	X	X	X	X
	20	-	-	-	-	-	-	-	-	-	-	X	-	-	-	-

MG = diaphragm size

For further plastic diaphragm valves, accessories and other products, please see our Product Range catalogue and Price List.
 Contact GEMÜ.

GEMÜ® VALVES, MEASUREMENT
 AND CONTROL SYSTEMS

