

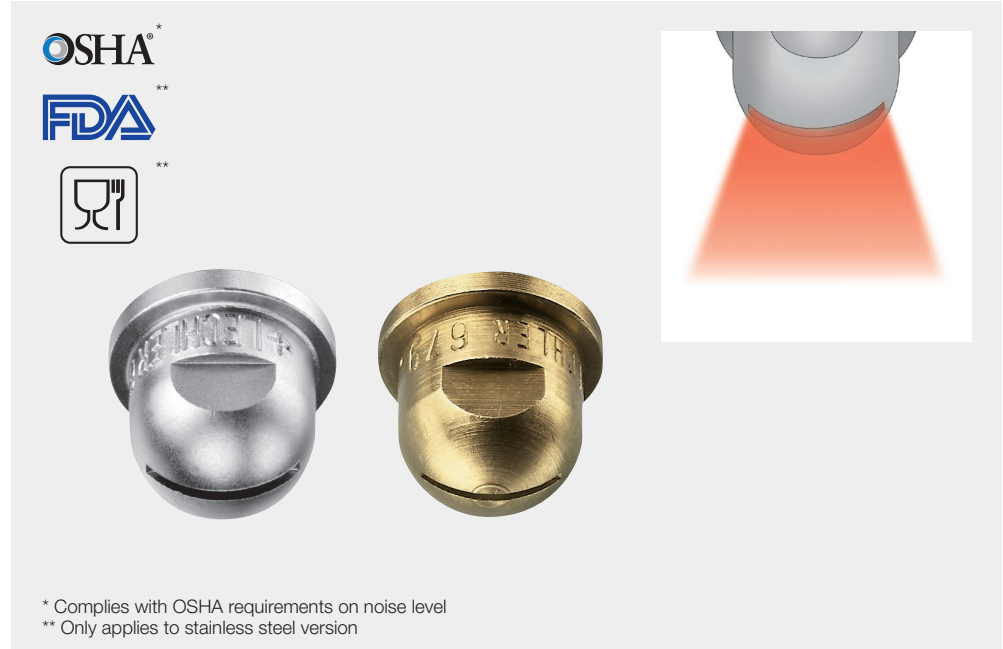

Flat jet slotted nozzle tips for air or saturated steam Series 679

Series 679

The flat jet nozzle tips of the 679 series are characterized by their wide, powerful air jet. Due to the special nozzle design, the jet angle is approx. 70° – 90°. Mounting with a retaining nut allows for an easy installation and alignment of the nozzles.



Materials
Stainless steel
AISI 316Ti,
Brass



Noise level
67-92 db(A) at 2 bar



Air consumption
see table



Pressure
 $P_{max} = 10$ bar

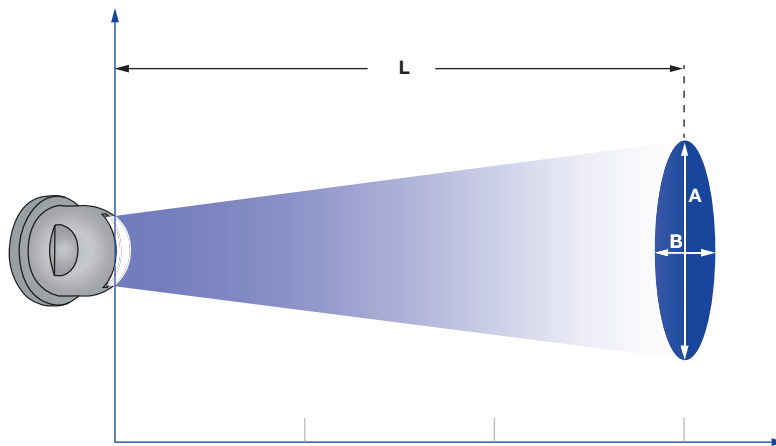

Jet pattern of 679 nozzle series

Pressure:		1 bar	3 bar	5 bar
679.037	Distance L [mm]:	50	100	150
	A [mm]:	110	260	380
	B [mm]:	25	35	45
679.117	Distance L [mm]:	50	125	150
	A [mm]:	100	250	310
	B [mm]:	25	30	35
679.255	Distance L [mm]:	375	500	500
	A [mm]:	90	190	280
	B [mm]:	90	90	90

Pressure:		1 bar	3 bar	5 bar
679.415	Distance L [mm]:	675	900	900
	A [mm]:	160	300	460
	B [mm]:	215	215	215
679.495	Distance L [mm]:	900	900	900
	A [mm]:	200	425	510
	B [mm]:	230	230	230

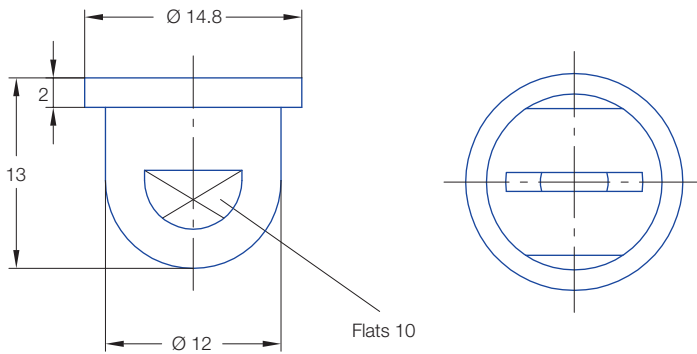

Spray angle 	Ordering no.		A Ø [mm]	\dot{V}_n Air [m³/h]				\dot{M} Saturated steam [kg/h]				
	Type	Mat. no.		p [bar]				p [bar]				
		17		30								
		AISI 316Ti		Brass	0.5	2.0	5.0	10.0	0.5	2.0	5.0	10.0
approx. 70°–90°	679.037	-	○	1.2	1.50	3.00	6.00	11.00	1.20	2.30	4.60	8.30
	679.085	○	○	1.3	2.00	4.00	8.00	14.70	1.60	3.10	6.10	11.10
	679.117	○	○	1.5	2.10	4.20	8.40	15.40	1.70	3.30	6.50	11.70
	679.165	○	○	1.8	2.60	5.10	10.30	18.80	2.00	4.10	8.00	14.30
	679.255	○	○	2.1	3.60	7.30	14.50	26.60	2.80	5.70	11.20	20.20
	679.365	○	○	2.8	6.30	12.70	25.40	46.50	5.00	10.00	19.60	35.30
	679.415	○	○	3.6	10.20	20.30	40.70	74.60	8.00	16.00	31.40	56.70
	679.495	○	○	4.3	15.60	31.10	62.20	114.00	12.40	24.80	48.50	87.60

A = Equivalent bore diameter

Example of ordering:	Type	+	Mat. no.	=	Ordering no.
	679.037.	+	30	=	679.037.30.00