

# Diaphragm Valve, Metal

## Construction

The GEMÜ 695 pneumatically operated 2/2-way diaphragm valve has a low maintenance membrane actuator which can be controlled by inert gaseous media. Normally Closed, Normally Open and Double Acting control functions are available.

## Features

- Suitable for inert and corrosive\* liquid and gaseous media
- Insensitive to particulate media
- Valve body and diaphragm available in various materials and designs
- Surface finishes down to 0.25 µm, electropolished
- Versions according to ATEX on request

## Advantages

- Optional flow direction, will seal in either flow direction up to full operating pressure
- Optional mounting position
- Weight-saving design
- Optional accessories:
  - Stroke limiter
  - Optical position indicator
  - Manual override (GEMÜ 1002, GEMÜ 1004)
  - Pilot valve with manual override (GEMÜ 0322 - 0326)
  - Electrical position indicator

\*see information on working medium on page 2



Sectional drawing

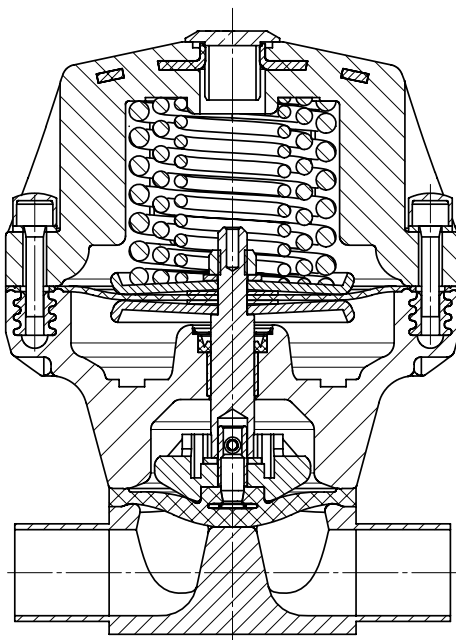

## Technical data

### Working medium

Corrosive, inert, gaseous and liquid media which have no negative impact on the physical and chemical properties of the body and diaphragm material.

The valve will seal in both flow directions up to full operating pressure. (All pressures are gauge pressures.)

Operating temperature (dependent on medium wetted materials) max. 80 °C

### Control medium

Max. perm. temperature of control medium 40 °C

Filling volume (control function 1)

DN 15-25 0.15 dm<sup>3</sup>

DN 32-40 0.35 dm<sup>3</sup>

DN 50 1.10 dm<sup>3</sup>

### Ambient conditions

Max. ambient temperature 60 °C

### Control functions 2 + 3

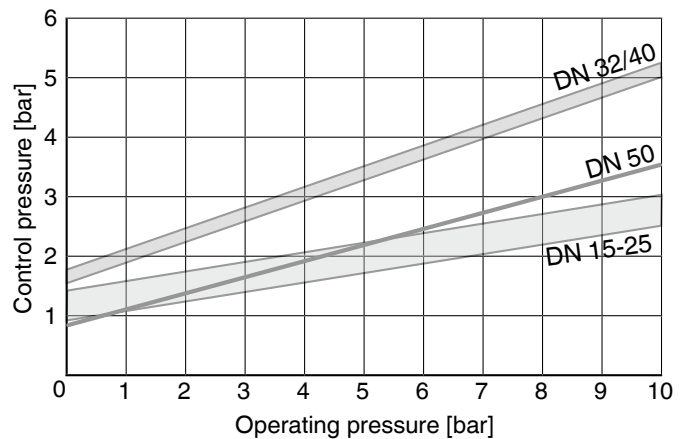

The values shown relate to control function 2 (with opening spring). For control function 3 (without opening spring) control pressure is approx. 1 bar lower.

Diaphragm size	DN	Operating pressure [bar]		Control pressure [bar]		
		EPDM / FPM	PTFE	Control function 1	Control function 2	Control function 3
25	15	0 - 10	0 - 6	5.5 - 7.0	max. 5.5	max. 5.5
	20					
	25					
40	32	0 - 10	0 - 6	5.5 - 7.0	max. 5.5	max. 5.5
	40					
50	50	0 - 10	0 - 6	5.5 - 7.0	max. 5.0	max. 5.0

All pressures are gauge pressures. Operating pressure values were determined with static operating pressure applied on one side of a closed valve. Sealing at the valve seat and atmospheric sealing is ensured for the given values. Information on operating pressures applied on both sides and for high purity media on request.

### Kv values [m<sup>3</sup>/h]

MG	DN	DIN Code 0	DIN 11850 Series 1 Code 16	DIN 11850 Series 2 Code 17	DIN 11850 Series 3 Code 18	SMS 3008 Code 37	ASME BPE Code 59	EN ISO 1127 Code 60
25	15	4.1	4.7	4.7	4.7	-	-	7.4
	20	6.3	7.0	7.0	7.0	-	4.4	13.2
	25	13.9	15.0	15.0	15.0	12.6	12.2	16.2
40	32	25.3	27.0	27.0	27.0	26.2	-	30.0
	40	29.3	30.9	30.9	30.9	30.2	29.5	32.8
50	50	46.5	48.4	48.4	48.4	51.7	50.6	55.2

Kv values determined acc. to IEC 534 standard, inlet pressure 6 bar, Δp 1 bar, stainless steel valve body and soft elastomer diaphragm. MG = diaphragm size

### Diaphragm temperature range [°C]

Diaphragm	Liquid Media		Code
	Min.	Max.	
EPDM	-10	80	13
EPDM	-10	80	14
EPDM	-10	80	17
PTFE	-10	80	52
PTFE	-10	80	5E
FPM	-10	80	4
PTFE	-10	80	5F

## Order data

Body configuration	Code
2/2-way body	D

Connection	Code
------------	------

### Butt weld spigots

Spigots DIN	0
Spigots DIN 11850, series 1	16
Spigots DIN 11850, series 2	17
Spigots DIN 11850, series 3	18
Spigots DIN 11866, series A	1A
Spigots DIN 11866, series B	1B
Spigots JIS-G 3447	35
Spigots JIS-G 3459	36
Spigots SMS 3008	37
Spigots BS 4825, part 1	55
Spigots ASME BPE	59
Spigots EN ISO 1127	60
Spigots ANSI/ASME B36.19M, Schedule 10s	63
Spigots ANSI/ASME B36.19M, Schedule 40s	65

### Threaded connections

Threaded sockets DIN ISO 228	1
Threaded spigots DIN 11851	6
One side threaded spigot, other side cone spigot and union nut, DIN 11851	62
Aseptic unions on request	

### Flanges

Flanges EN 1092 / PN16 / form B, length EN 558, series 1, ISO 5752, basic series 1	8
Flanges ANSI CLASS 125/150 RF, length MSS SP-88	38
Flanges ANSI CLASS 125/150 RF, length EN 558, series 1, ISO 5752, basic series 1	39

### Clamp connections

Clamps ASME BPE for pipe ASME BPE, length ASME BPE	80
Clamps DIN 32676 series B for pipe EN ISO 1127, length EN 558, series 7	82
Clamps ASME BPE for pipe ASME BPE, length EN 558, series 7	88
Clamps DIN 32676 series A for pipe DIN 11850, length EN 558, series 7	8A
Clamps SMS 3017 for pipe SMS 3008, length EN 558, series 7	8E
Aseptic clamps on request	

For overview of available valve bodies for GEMÜ 695 see page 8

Valve body material	Code
EN-GJL-250, (GG25) (Cast iron)	8
EN-GJS-400-18-LT (S.G. Iron 40.3), PFA lined	17
EN-GJS-400-18-LT (S.G. Iron 40.3), PP lined	18
1.4435 - BN2 (CF3M), investment casting Fe<0.5%	32
1.4435 (ASTM A 351 CF3M $\Delta$ 316L), investment casting	34
1.4408, investment casting	37
1.4408, PFA lined	39
1.4435 (316L), forged body	40
1.4435 (BN2), forged body Fe<0.5%	42
EN-GJS-400-18-LT (S.G. Iron 40.3), hard rubber lined	83

Diaphragm material	Code
--------------------	------

FPM	4
EPDM	13
EPDM	14
EPDM	17
PTFE/EPDM convex, PTFE loose	5E
PTFE/FPM convex, PTFE loose	5F
PTFE/EPDM, PTFE lamin.	52

Material complies with FDA requirements, except codes 4 and 14

The combination of PFA or PTFE lining with 5E diaphragms is only conditionally suitable for gaseous media. If low seat leakage rates are required for gaseous media, other combinations are preferable.

Control function	Code
------------------	------

Normally closed (NC)	1
Normally open (NO)	2
Double acting (DA)	3

Actuator size	Code
---------------	------

Diaphragm size 25	1/N
Diaphragm size 40	2/N
Diaphragm size 50	3/N

For further order data see page 4

## Order data

### Valve body surface finish, internal contour

		Forged body Code 40, 42	Investment casting Code 32, 34	Code
Ra ≤ 6.3 µm	blasted internal/external	-	X	1500
--	electropolished	-	X	1509
Ra ≤ 0.8 µm	mechanically polished internal, blasted external	X	X	1502
Ra ≤ 0.8 µm	electropolished internal/external	X	-	1503
Ra ≤ 0.6 µm	mechanically polished internal, blasted external	X	X	1507
Ra ≤ 0.6 µm	electropolished internal/external	X	-	1508
Ra ≤ 0.4 µm	mechanically polished internal, blasted external	X	-	1536
Ra ≤ 0.4 µm	electropolished internal/external	X	-	1537
Ra ≤ 0.25 µm	mechanically polished internal, blasted external	X	-	1527
Ra ≤ 0.25 µm	electropolished internal/external	X	-	1516

Ra acc. to DIN 4768; at defined reference points

Surface finish data refer to medium wetted surfaces

Order example	695	25	D	60	34	17	1	1/N	1500
Type	695								
Nominal size		25							
Body configuration (code)			D						
Connection (code)				60					
Valve body material (code)					34				
Diaphragm material (code)						17			
Control function (code)							1		
Actuator size (code)								1/N	
Surface finish (code)									1500

## Actuator dimensions [mm]

### Control function 1

MG	DN	ø B	A	A1	Weight [kg]
25	15 - 25	125	131	47	1.5
40	32 - 40	155	177	75	3.0
50	50	210	215	90	5.5

### Control functions 2 + 3

MG	DN	ø B	A	A1	A2	Weight [kg]
25	15 - 25	125	98	47	27	1.0
40	32 - 40	155	135	75	27	2.1
50	50	210	164	90	29	3.6

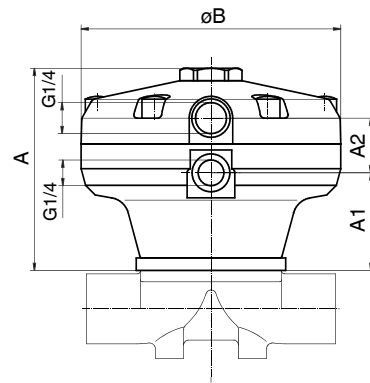
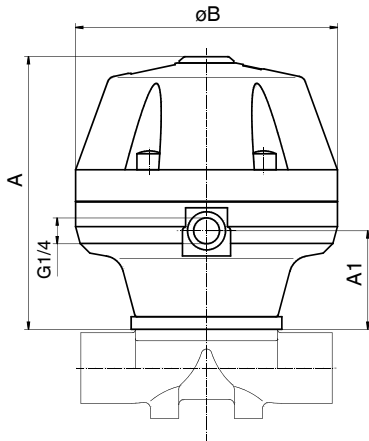

## Body dimensions [mm]

### Threaded sockets, connection code 1

Valve body material: GG25 (code 8), investment casting (code 37)

MG	DN	R	L	Material code 8					Material code 37					Weight [kg]
				H	H1	t	SW2	Number of flats	H	H1	t	SW2	Number of flats	
25	15	1/2"	85	35	19	12	32	6	30	16	9	27	6	0.32
	20	3/4"	85	40	19	13	41	6	33	17	10	32	6	0.34
	25	1"	110	42	19	16	46	6	37	17	13	41	6	0.39
40	32	1 1/4"	120	56	28	16	55	6	50	25	16	50	8	0.88
	40	1 1/2"	140	61	28	18	65	6	52	25	18	55	8	0.93
50	50	2"	165	73	35	18	75	6	69	34	18	70	8	1.56

MG = diaphragm size

For materials see overview on last page

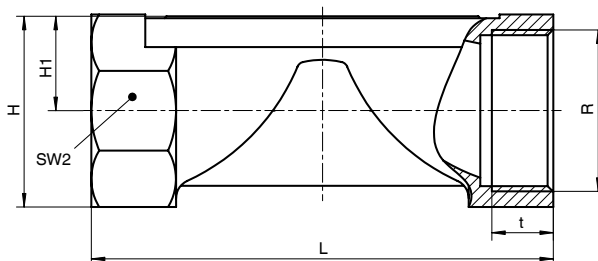

## Body dimensions [mm]

### Butt weld spigots, connection code 0, 16, 17, 18 Valve body material: Investment casting (code 34), forged body (code 40)

MG	DN	NPS	f*	øg*	L	c	H1*	H1**	DIN Series 0 Code 0		DIN 11850 Series 1 Code 16		DIN 11850 Series 2 Code 17		DIN 11850 Series 3 Code 18		Weight [kg]
									ød	s	ød	s	ød	s	ød	s	
25	15	1/2"	40	13.5	120	25	13.0	19.0	18	1.5	18	1.0	19	1.5	20	2.0	0.62
	20	3/4"	40	13.5	120	25	16.0	19.0	22	1.5	22	1.0	23	1.5	24	2.0	0.58
	25	1"	40	13.5	120	25	19.0	19.0	28	1.5	28	1.0	29	1.5	30	2.0	0.55
40	32	1 1/4"	68	13.5	153	25	24.0	26.0	34	1.5	34	1.0	35	1.5	36	2.0	1.45
	40	1 1/2"	75	13.5	153	25	26.0	26.0	40	1.5	40	1.0	41	1.5	42	2.0	1.32
50	50	2"	90	13.5	173	30	32.0	32.0	52	1.5	52	1.0	53	1.5	54	2.0	2.25

\* only for investment cast design      \*\* only for forged design      MG = diaphragm size  
For materials see overview on last page

### Butt weld spigots, connection code 1A, 1B, 60 Valve body material: Investment casting (code 34), forged body (code 40)

MG	DN	NPS	f*	øg*	L	c	H1*	H1**	DIN 11866 Series A Code 1A		DIN 11866 Series B Code 1B		EN ISO 1127 Code 60		Weight [kg]
									ød	s	ød	s	ød	s	
25	15	1/2"	40	13.5	120	25	13.0	19.0	19	1.5	21.3	1.6	21.3	1.6	0.62
	20	3/4"	40	13.5	120	25	16.0	19.0	23	1.5	26.9	1.6	26.9	1.6	0.58
	25	1"	40	13.5	120	25	19.0	19.0	29	1.5	33.7	2.0	33.7	2.0	0.55
40	32	1 1/4"	68	13.5	153	25	24.0	26.0	35	1.5	42.4	2.0	42.4	2.0	1.45
	40	1 1/2"	75	13.5	153	25	26.0	26.0	41	1.5	48.3	2.0	48.3	2.0	1.32
50	50	2"	90	13.5	173	30	32.0	32.0	53	1.5	60.3	2.0	60.3	2.0	2.25

\* only for investment cast design      \*\* only for forged design      MG = diaphragm size  
For materials see overview on last page

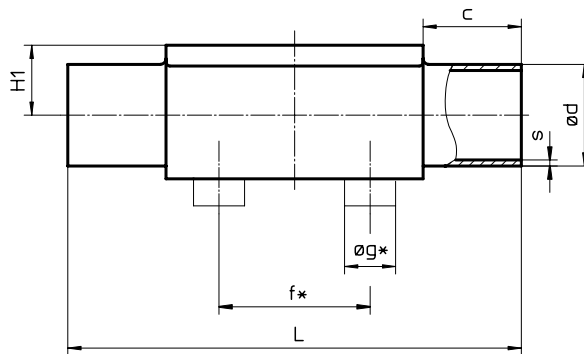

## Body dimensions [mm]

### Butt weld spigots, connection code 35, 36, 37 Valve body material: Investment casting (code 34), forged body (code 40)

MG	DN	NPS	f*	øg*	L	c	H1*	H1**	JIS-G 3447 Code 35		JIS-G 3459 Code 36		SMS 3008 Code 37		Weight [kg]
									ød	s	ød	s	ød	s	
25	15	1/2"	40	13.5	120	25	13.0	19.0	-	-	21.7	2.10	-	-	0.62
	20	3/4"	40	13.5	120	25	16.0	19.0	-	-	27.2	2.10	-	-	0.58
	25	1"	40	13.5	120	25	19.0	19.0	25.4	1.2	34.0	2.80	25.0	1.2	0.55
40	32	1 1/4"	68	13.5	153	25	24.0	26.0	31.8	1.2	42.7	2.80	33.7	1.2	1.45
	40	1 1/2"	75	13.5	153	25	26.0	26.0	38.1	1.2	48.6	2.80	38.0	1.2	1.32
50	50	2"	90	13.5	173	30	32.0	32.0	50.8	1.5	60.5	2.80	51.0	1.2	2.25

\* only for investment cast design      \*\* only for forged design      MG = diaphragm size  
For materials see overview on last page

### Butt weld spigots, connection code 55, 59, 63, 65 Valve body material: Investment casting (code 34), forged body (code 40)

MG	DN	NPS	f*	øg*	L	c	H1*	H1**	BS 4825 Code 55		ASME BPE Code 59		ANSI/ASME B36.19M 10s Code 63		ANSI/ASME B36.19M 40s Code 65		Weight [kg]
									ød	s	ød	s	ød	s	ød	s	
25	15	1/2"	40	13.5	120	25	13.0	19.0	-	-	-	-	21.3	2.11	21.3	2.77	0.62
	20	3/4"	40	13.5	120	25	16.0	19.0	19.05	1.2	19.05	1.65	26.7	2.11	26.7	2.87	0.58
	25	1"	40	13.5	120	25	19.0	19.0	-	-	25.40	1.65	33.4	2.77	33.4	3.38	0.55
40	32	1 1/4"	68	13.5	153	25	24.0	26.0	-	-	-	-	42.2	2.77	42.2	3.56	1.45
	40	1 1/2"	75	13.5	153	25	26.0	26.0	-	-	38.10	1.65	48.3	2.77	48.3	3.68	1.32
50	50	2"	90	13.5	173	30	32.0	32.0	-	-	50.80	1.65	60.3	2.77	60.3	3.91	2.25

\* only for investment cast design      \*\* only for forged design      MG = diaphragm size  
For materials see overview on last page

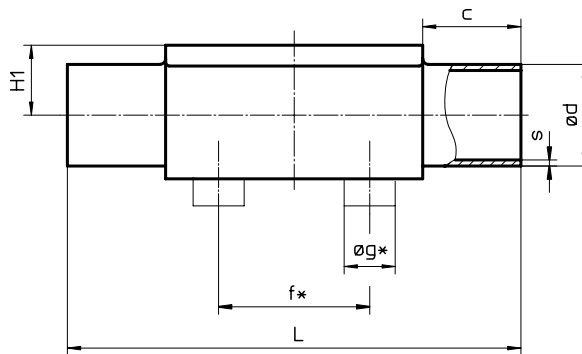

## Body dimensions [mm]

**Flanges - DIN EN 1092, connection code 8**  
**Valve body material: GG25 (code 8), S.G. Iron 40.3 (code 17, 18, 83),**  
**1.4435 (code 34, 40), 1.4408 (code 39)**

MG	DN	øD	øk	øL	Number of bolt	H1				FTF	Weight [kg]
						Material code 8	Material code 17, 18, 39, 83	Material code 34	Material code 40		
25	15	95	65	14	4	19.0	18.0	13.0	19.0	130*	1.85
	20	105	75	14	4	19.0	20.5	16.0	19.0	150	2.35
	25	115	85	14	4	19.0	23.0	19.0	19.0	160	2.85
40	32	140	100	18	4	28.0	28.7	24.0	26.0	180	4.90
	40	150	110	18	4	28.0	33.0	26.0	26.0	200	5.65
50	50	165	125	18	4	35.0	39.0	32.0	32.0	230	7.45

\*Material code 34, 40 FTF = 150 (no DIN length)

MG = diaphragm size

For materials see overview on last page

**Flanges - ANSI class 125/150 RF, connection code 38, 39**  
**Valve body material: GG25 (code 8), S.G. Iron 40.3 (code 17, 18, 83),**  
**1.4435 (code 34, 40), 1.4408 (code 39)**

MG	DN	øD	øk	øL	Number of bolt	H1				FTF		Weight [kg]	
						Connection code 38, 39				MSS Sp-88 Connection-code 38			EN 558 Series 1 Connection-code 39
										Material code 8	Material code 17, 18, 39, 83		Material code 34
25	15	90	60.3	15.9	4	19.0	18.0	13.0	19.0	-	-	130	1.85
	20	100	69.9	15.9	4	19.0	20.5	16.0	19.0	146	146.4	150	2.35
	25	110	79.4	15.9	4	19.0	23.0	19.0	19.0	146	146.4	160	2.85
40	32	115	88.9	15.9	4	28.0	28.7	24.0	26.0	-	-	180	4.90
	40	125	98.4	15.9	4	28.0	33.0	26.0	26.0	175	171.4	200	5.65
50	50	150	120.7	19.0	4	35.0	39.0	32.0	32.0	200	197.4	230	7.45

MG = diaphragm size

For materials see overview on last page

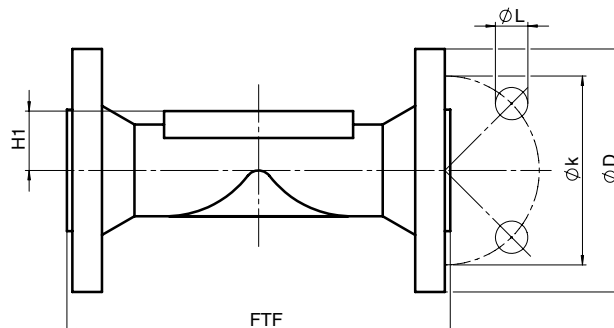



## Body dimensions [mm]

### Threaded connections, connection code 6, 62 Valve body material: investment casting (code 34), forged body (code 40)

MG	DN	H1*	H1**	f*	øg*	ød1	Thread to DIN 405 R	Code 6 L	Code 62 L	Weight [kg]
25	15	13.0	19	40.0	13.5	16.0	RD 34 x 1/8	118	116	0.71
	20	16.0	19	40.0	13.5	20.0	RD 44 x 1/6	118	114	0.78
	25	19.0	19	40.0	13.5	26.0	RD 52 x 1/6	128	127	0.79
40	32	24.0	26	68.0	13.5	32.0	RD 58 x 1/6	147	147	1.66
	40	26.0	26	75.0	13.5	38.0	RD 65 x 1/6	160	160	1.62
50	50	32.0	32	90.0	13.5	50.0	RD 78 x 1/6	191	191	2.70

\* only for investment cast design

\*\* only for forged design

MG = diaphragm size

For materials see overview on last page

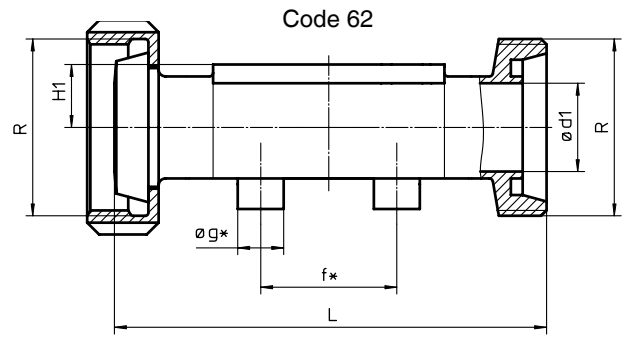
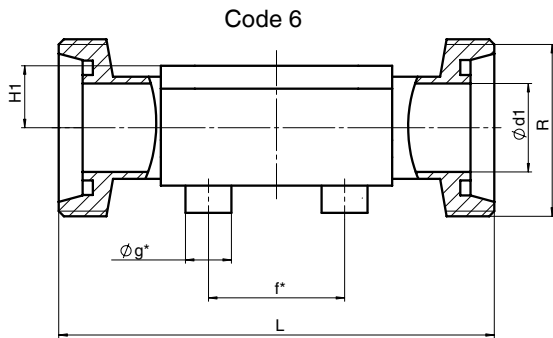

### Clamp connections, connection code 80, 82, 88, 8A, 8E Valve body material: forged body (code 40)

MG	DN	NPS	H1	for pipe ASME BPE Code 80			for pipe EN ISO 1127 Code 82			for pipe ASME BPE Code 88			for pipe DIN 11850 Code 8A			for pipe SMS 3008 Code 8E			Weight [kg]
				ød1	ød3	L	ød1	ød3	L	ød1	ød3	L	ød1	ød3	L	ød1	ød3	L	
25	15	1/2"	19.0	-	-	-	18.1	50.5	108.0	-	-	-	16	34.0	108.0	-	-	-	0.75
	20	3/4"	19.0	15.75	25.0	101.6	23.7	50.5	117.0	15.75	25.0	117	20	34.0	117.0	-	-	-	0.71
	25	1"	19.0	22.10	50.5	114.3	29.7	50.5	127.0	22.10	50.5	127	26	50.5	127.0	22.6	50.5	127	0.63
40	32	1 1/4"	26.0	-	-	-	38.4	64.0	146.0	-	-	-	32	50.5	146.0	31.3	50.5	146	1.62
	40	1 1/2"	26.0	34.80	50.5	139.7	44.3	64.0	159.0	34.80	50.5	159	38	50.5	159.0	35.6	50.5	159	1.50
50	50	2"	32.0	47.50	64.0	158.8	56.3	77.5	190.0	47.50	64.0	190	50	64.0	190.0	48.6	64.0	190	2.50

MG = diaphragm size

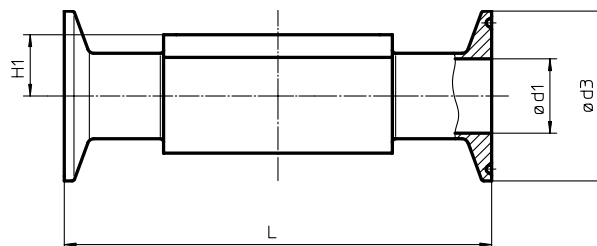

## Overview of valve bodies for GEMÜ 695

		Threaded connections						Spigots																											
Connection code		1		6		62		0		16		17		18		1A		1B		35		36		37		55		59		60		63		65	
Material code		8	37	34	40	34	40	34	40	34	40	34	40	34	40	40	40	34	40	40	34	40	34	40	34	40	34	40	34	40	40	40			
MG	DN																																		
25	15	X*	X	W	W	W	W	X	X	X	X	X	X	-	X	X	X	-	-	X	-	-	-	-	-	-	-	X	X	X	X				
	20	X*	X	W	W	W	W	X	X	X	X	X	X	-	X	X	X	-	-	X	-	-	X	X	X	X	X	X	X	X	X				
	25	X*	X	W	W	W	W	X	X	X	X	X	X	X	X	X	X	X	X	X	X	X	X	-	-	X	X	X	X	X	X				
40	32	X*	X	W	W	W	W	X	X	X	X	X	X	X	X	X	X	X	X	X	X	X	-	-	-	-	X	X	X	X					
	40	X*	X	W	W	W	W	X	X	X	X	X	X	X	X	X	X	X	X	X	X	X	-	-	X	X	X	X	X	X					
50	50	X*	X	W	W	W	W	X	X	X	X	X	X	X	X	X	X	X	X	X	X	X	-	-	X	X	X	X	X	X					

\*Valve bodies are not suitable for use with diaphragm code 5E, 5F

X = Standard

W = Welded construction

MG = diaphragm size

		Clamps					Flanges																	
Connection code		80	82	88	8A	8E	8						38				39							
Material code		40	40	40	40	40	8	17	18	34	39	40	83	17	18	39	83	8	17	18	34	39	40	83
MG	DN																							
25	15	-	W	-	K	-	X*	X	X	W	X	W	X	-	-	-	-	X*	X	X	W	X	W	X*
	20	K	K	K	K	-	X*	X	X	W	X	W	X	X	X	X	X*	X*	X	X	W	X	W	X*
	25	K	K	K	K	K	X*	X	X	W	X	W	X	X	X	X	X*	X*	X	X	W	X	W	X*
40	32	-	W	-	K	K	X*	X	X	W	X	W	X	-	-	-	-	X*	X	X	W	X	W	X*
	40	K	W	K	K	K	X*	X	X	W	X	W	X	X	X	X	X*	X*	X	X	W	X	W	X*
50	50	K	W	K	K	K	X*	X	X	W	X	W	X	X	X	X	X*	X*	X	X	W	X	W	X*

\*Valve bodies are not suitable for use with diaphragm code 5E, 5F

X = Standard

K = Connections completely machined (not welded) in material code 40

W = Welded construction

MG = diaphragm size

Connection code 38 / Material code 18 on request

Availability of material code 32 same as code 34, code 42 same as code 40

For further metal diaphragm valves, accessories and other products, please see our Product Range catalogue and Price List.  
Contact GEMÜ.

**GEMÜ**® VALVES, MEASUREMENT  
AND CONTROL SYSTEMS

