

Diaphragm Valve, Metal / Plastic

Construction

The GEMÜ 648 motorized 2/2-way valve has a compact electric linear actuator with a motor designed for DC and AC operating voltages. The integrated gear translates the rotary motor movement into a linear movement.

The actuator is available as an Open/Close version or with an integrated positioner and additional process controller.

The membrane keypad and the backlit display are at the front of the unit and easily accessible.

The integrated electronic system enables easy setting of actuating speed, control parameters and other functions.

Features

- Suitable for inert and corrosive* liquid and gaseous media
- OPEN/CLOSE function or CONTROL version
- Actuating speed and control parameters easily adjustable
- Optimized initialisation and valve control
- Parameterisation during operation
- Torque limitation
- Electronic limitation of opening and closing stroke
- Positioner and process controller are synchronized with each other
- Optional integrated emergency power supply module with selectable safety position
- Setting of functions via display

Advantages

- Can be combined with virtually all GEMÜ diaphragm valve bodies
- 2-colour LEDs with good visibility for indication of end position and travel direction
- Extensive integrated diagnostic functions
- Simple commissioning and versatile operating facilities
 - Fascia keys
 - PC connection with Internet browser MS® Internet Explorer
 - Field bus interfaces, e.g. Profibus DP
 - e.^{SY}-com interface for connecting a Bluetooth module or industrial modem to enable access via PDA or PC

*see information on working medium on page 2



GEMÜ 648

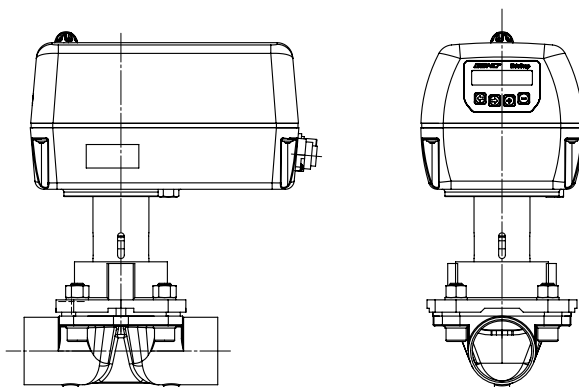

For installation dimensions see page 5.

Technical data

Working medium

Corrosive, inert, gaseous and liquid media which have no negative impact on the physical and chemical properties of the body and diaphragm material.

Max. perm. pressure of working medium see table

Max. perm. temp. of working medium 150° C (standard)

Operating conditions

Storage temperature -10 to +60°C
Ambient temperature see Derating curve on page 3

General information

Protection class to EN 60529 IP 65
Weight See table
Dimensions L x W x H See dimensional drawing
Mounting position Optional
Particulars: Safety function during electrical power supply failure (by optional emergency power supply module)

Position indication

LED 2-colour, good visibility

Directives

EC low voltage directive 73/23/EEC
EMC directive 89/336/EEC
Interference emission EN 61000-6-4
Interference resistance EN 61000-6-2
Rating 40%

Actuator materials

Housing cover PSU
Housing base PPS 40 glass reinforced
Distance piece 1.4301

Electrical data (all versions)

Power supply

Power supply $U_V = 24V DC \pm 10\%$
max. residual ripple $\pm 10\%$
 $U_V = 120V 50/60 Hz \pm 10\%$
 $U_V = 230V 50/60 Hz \pm 10\%$
Power consumption DC approx. 96 W
AC approx. 120 VA

Electrical connection (see electrical connection pages 4+5)

Power supply 1 x Binder series 693
Input/output signals 1 x M12 plug, A-coded
(not Profibus DP) 1 x M12 socket, A-coded
1 x M12 plug, B-coded

Operating elements

Keys 4 membrane protected fascia keys

Electrical data (Economy version)

Input signals

Control inputs 2 x 24V DC
Voltage $U_{rated} = 24V DC$
Level "Logical 1" $14V DC \leq U_H \leq 28V DC$
Level "Logical 0" $0V DC \leq U_L \leq 8V DC$
Input current $I_{typ} = 2.5 mA (@ 24V DC)$

Electrical data (Industrial version)

Input signals

Control inputs 2 x 24V DC
Digital inputs 2 x (optional)
Function selectable (ON, OFF, safety position, loading of parameter set)
Voltage $U_{rated} = 24V DC$
Level "Logical 1" $14V DC \leq U_H \leq 28V DC$
Level "Logical 0" $0V DC \leq U_L \leq 8V DC$
Input current $I_{typ} = 2.5 mA (@ 24V DC)$

Output signals

Digital outputs
Number 2 relay outputs (potential-free)
Switching voltage $= U_V$
Switching current $\leq 0.5 A$
Function selectable
(position, warnings, errors)

Display elements

Text display 2-line display with 16 digits each, with background light
LED Field bus status
(only with Profibus DP version)

Interfaces

PC interface RS 232 with PPP protocol for Internet browser
Field bus Profibus DP V1 interface certified

Electrical data (Industrial version with integrated control module)

Analogue inputs *)

Set value external 0/4 - 20 mA (selectable)
(for version with positioner)
Actual value external 0/4 - 20 mA (selectable)
(for version with process controller)
Input resistance 120 Ω

Analogue output

Actual value position feedback 4 - 20 mA

Digital inputs

Number of integrated inputs 2 inputs (use of the analogue inputs)
Voltage $U_{rated} = 24V DC$
Level "Logical 1" $14V DC \leq U_H \leq 28V DC$
Level "Logical 0" $0V DC \leq U_L \leq 8V DC$
Input current $I_{typ} = 18 mA (@ 24V DC)$

Positioner

Deviation $\geq 0.1\%$ (adjustable)
P D parameters adjustable
Initialisation automatic or manual

Process controller (for version with process controller)

Type of controller continuous controller
PID parameters adjustable

*) Analogue inputs can be used as digital inputs by external wiring with a resistor according to the operating instructions and software function.

Electrical data

(optional integrated emergency power supply module)

Charging time max. 3 min
(for complete charging)
Additional current consumption during charging process max. 3 A
Number of guaranteed switching cycles at full load 1 switching cycle

Technical data

Mechanical actuator data

Actuator version 2D

Stroke	28.8 mm
Actuating speed	max. 3.3 mm/sec.
Axial force	4500 N
Actuator size	2

Actuator version 3F

Stroke	46.0 mm
Actuating speed	max. 1.85 mm/sec.
Axial force	7800 N
Actuator size	3

Actuator version 3G

Stroke	37.4 mm
Actuating speed	max. 1.04 mm/sec.
Axial force	14000 N
Actuator size	3

Derating curve

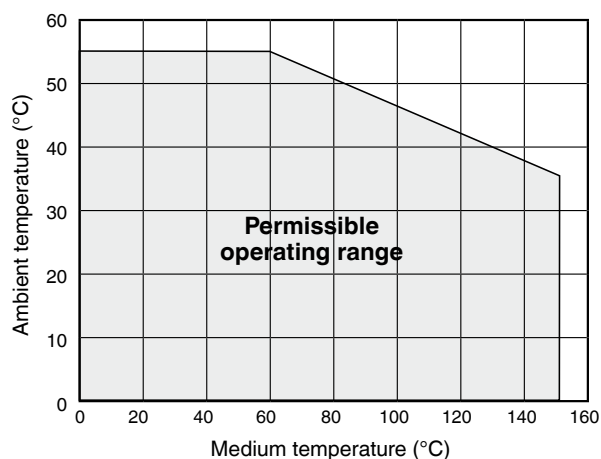

MG	DN	Max. operating pressure [bar]						Kv value
		Actuator version 2D		Actuator version 3F		Actuator version 3G		[m ³ /h]
		Diaphragm material		Diaphragm material		Diaphragm material		
		EPDM	PTFE	EPDM	PTFE	EPDM	PTFE	
25	15							see data sheet 620, 687, 690
	20	10	6	-	-	-	-	
	25							
40	32	10	6	-	-	-	-	
	40							
50	50	10	6	-	-	-	-	
80	65	-	-	8	5	10	6	
	80							
100	100	-	-	-	-	10	6	

Features of the different actuator versions

Features	SideStep® Economy OPEN / CLOSE control	SideStep® Industrial OPEN / CLOSE control	SideStep® Industrial control system
	Code A*	Code C, D	Code S, T, P, R
2-line display	-	X	X
Automatic initialisation	X	X	X
4 fascia keys	X	X	X
Position indication by LED	X	X	X
Operating indication by LED	X	-	-
e.SY-com interface	-	X	X
Axial force (adjustable)	-	X	X
Actuating speed (adjustable)	-	X	X
Option Profibus	-	X	X
Positioner	-	-	X
Option process controller	-	-	X
Option digital inputs	-	X	X
Extended diagnostic facilities	-	X	X
Alarm outputs (adjustable)	-	X	X
Analogue output	-	-	X
Min / Max position (adjustable)	-	-	X

* not available for actuator version 3

Electrical connection - OPEN/CLOSE Economy

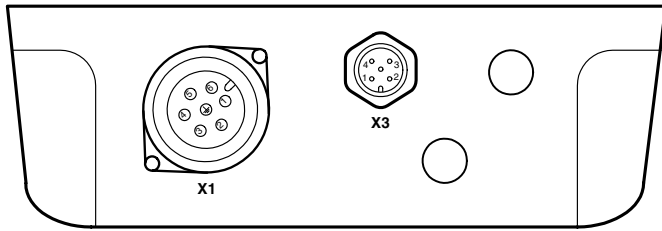

Connection	Pin	Signal name
X3 M12 plug A-coded	1	U _v , signal supply, 24V DC
	2	L+, direction of travel OPEN
	3	GND, direction of travel OPEN/CLOSED
	4	L-, direction of travel CLOSED
	5	Input, keypad lock, 24V DC

Connection	Pin	Signal name
X1 Connector Binder series 693	1	U _v , L1 / L+ supply voltage
	2	U _v , N / L- supply voltage
	3	n.c.
	4	n.c.
	5	n.c.
	6	n.c.
	PE	Protective earth conductor

Electrical connection - OPEN/CLOSE Industrial

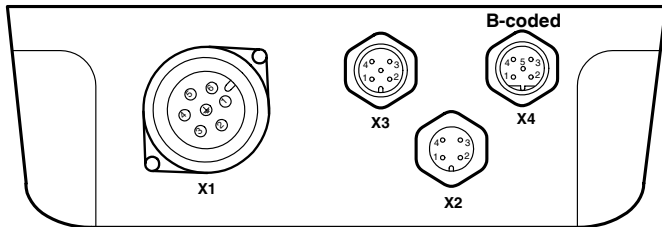

Connection	Pin	Signal name
X2 M12 socket A-coded	1	U _v , signal supply, 24V DC
	2	Digital input 1 (optional)
	3	GND, signal supply
	4	Digital input 2 (optional)

Connection	Pin	Signal name
X3 M12 plug A-coded	1	L+, direction of travel OPEN
	2	GND, direction of travel OPEN
	3	L-, direction of travel CLOSED
	4	GND, direction of travel CLOSED
	5	n.c.

Connection	Pin	Signal name
X1 Connector Binder series 693	1	U _v , L1 / L+ supply voltage
	2	U _v , N / L- supply voltage
	3	Common, relay output K1
	4	Make contact, relay output K1
	5	Common, relay output K2
	6	Make contact, relay output K2
	PE	Protective earth conductor

Connection	Pin	Signal name
X4 M12 plug B-coded	1	n.c.
	2	n.c.
	3	RxD, Receive Data, RS 232
	4	TxD, Transmit Data, RS 232
	5	GND, RS 232

Electrical connection - Positioner / process controller

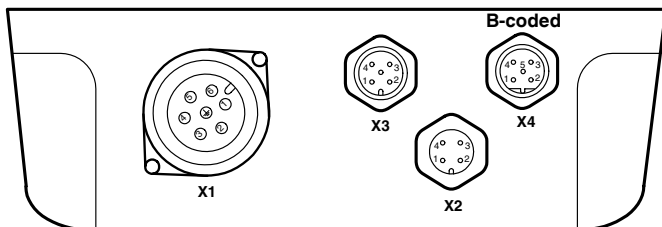

Connection	Pin	Signal name
X2 M12 socket A-coded	1	U _v , signal supply, 24V DC
	2	Digital input 1 (optional)
	3	GND, signal supply
	4	Digital input 2 (optional)

Connection	Pin	Signal name
X3 M12 plug A-coded	1	I+, set value input 0/4 - 20 mA
	2	I-, set value input 0/4 - 20 mA
	3	I+, actual value output 4 - 20 mA
	4	I-, actual value output 4 - 20 mA
	5	n.c.

Connection	Pin	Signal name
X1 Connector Binder series 693	1	U _v , L1 / L+ supply voltage
	2	U _v , N / L- supply voltage
	3	Common, relay output K1
	4	Make contact, relay output K1
	5	Common, relay output K2
	6	Make contact, relay output K2
	PE	Protective earth conductor

Connection	Pin	Signal name
X4 M12 plug B-coded	1	I+, actual value input 0/4 - 20 mA
	2	I-, actual value input 0/4 - 20 mA
	3	RxD, Receive Data, RS 232
	4	TxD, Transmit Data, RS 232
	5	GND, RS 232

Electrical connection - Profibus DP

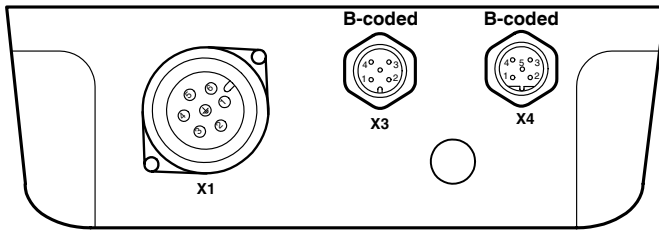

Connection	Pin	Signal name
X3 M12 plug B-coded	1	n.c.
	2	RxD / TxD-N
	3	n.c.
	4	RxD / TxD-P
	5	Shield

Connection	Pin	Signal name
X1 Connector Binder series 693	1	Uv, L1 / L+ supply voltage
	2	Uv, N / L- supply voltage
	3	n.c.
	4	n.c.
	5	n.c.
	6	n.c.
	PE	Protective earth conductor

Connection	Pin	Signal name
X4 M12 socket B-coded	1	BUS-VDC, +5V DC
	2	RxD / TxD-N
	3	GND
	4	RxD / TxD-P
	5	Shield

Installation dimensions [mm]

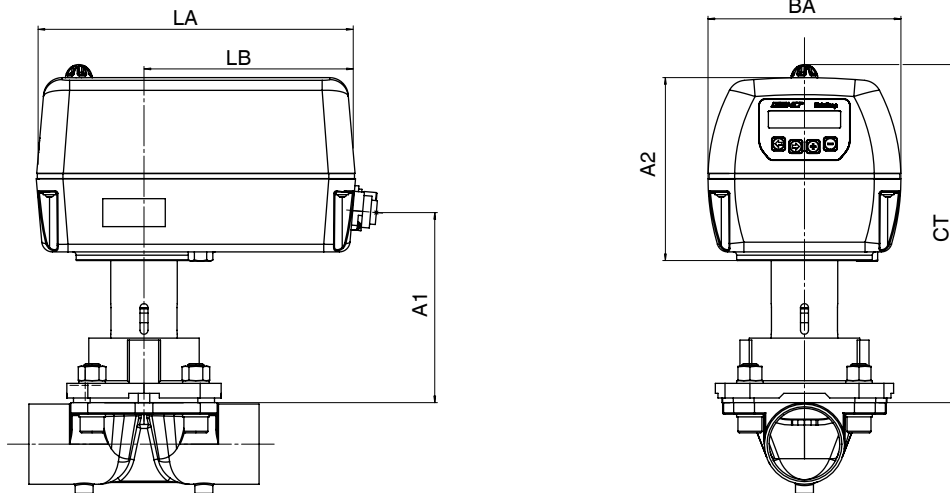

GEMÜ offers fastening facilities for the actuator on request

Installation dimensions

		Actuator version 2D							Actuator version 3F, 3G						
MG	DN	CT	A1	A2	LA	LB	BA	Weight [kg] actuator	CT	A1	A2	LA	LB	BA	Weight [kg] actuator
25	15 20 25	237	126	137.5	239	159	145	6.2	-	-	-	-	-	-	-
40	32 40	254	143	137.5	239	159	145	6.7	-	-	-	-	-	-	-
50	50	254	143	137.5	239	159	145	7.1	-	-	-	-	-	-	-
80	65 80	-	-	-	-	-	-	-	356	220	197	281	188	170	10.2
100	100	-	-	-	-	-	-	-	377	238	197	281	188	170	10.7

MG = diaphragm size

Order data

The SideStep® 9648 actuator can be combined with all diaphragm valve bodies of the 620, 687 and 690 type series.

Use the order codes for the diaphragm, body and surface finish stated in these data sheets in the order example below.

Supply voltage/mains frequency	Code
24V DC	C1
120V 50/60 Hz	G4
230V 50/60 Hz	L4

Option	Code
Without option	0
Digital inputs	1
Profibus DP	2

Main function	Code
OPEN/CLOSE control (Economy) * (not available for actuator version 3)	A
OPEN/CLOSE control (Industrial)	C
OPEN/CLOSE control (Industrial) + emergency power supply module (not available for actuator version 3)	D
Positioner	S
Positioner + emergency power supply module (not available for actuator version 3)	T
Process controller and positioner	P
Process controller and positioner + emergency power supply module (not available for actuator version 3)	R

Actuator version	Code
Actuator size 2, actuating force 4500 N	2D
Actuator size 3, actuating force 5500 N	3E
Actuator size 3, actuating force 7800 N	3F
Actuator size 3, actuating force 14000 N	3G

* With version "Main function A (Economy)" no options are possible.

Order example	648	50	D	0	34	14	C1	A	0	2D	1500
Type	648										
Nominal size		50									
Body configuration (code)			D								
Connection (code)				0							
Valve body material (code)					34						
Diaphragm material (code)						14					
Supply voltage/mains frequency (code)							C1				
Main function (code)								A			
Option (code)									0		
Actuator version (code)										2D	
Surface finish (code) (only for GEMÜ 687 stainless steel bodies)											1500

For further diaphragm valves, accessories and other products, please see our Product Range catalogue and Price List.
Contact GEMÜ.

GEMÜ® VALVES, MEASUREMENT
AND CONTROL SYSTEMS

